

# POPULAR COMMUNICATIONS

JULY 1993 \$2.95

\$3.95 CANADA

## DX'ing The Stars!

### Also in this issue:

- Scanning The Marijuana Freeways
- What About An Amateur Broadcasting Service?
- Low Frequency Antennas
- World Band Tuning Tips

JUN 17 1993



Plus: Car Phones, CB, Nostalgia, Satellites & More!





# NRD-535D

*"Best Communications Receiver"*

World Radio TV Handbook 1992



*"Unsurpassed DX Performance"*

Passport to World Band Radio 1992

Setting the industry standard once again for shortwave receivers, the NRD-535D is the most advanced HF communications receiver ever designed for the serious DXer and shortwave listener. Its unparalleled performance in all modes makes it the ultimate receiver for diversified monitoring applications.

Designed for DXers by DXers! The NRD-535D (shown above with optional NVA-319 speaker) strikes the perfect balance between form and function with its professional-grade design and critically acclaimed ergonomics. The NRD-535D is the recipient of the prestigious World Radio TV Handbook Industry Award for "Best Communications Receiver."

**JRC** *Japan Radio Co., Ltd.*

Japan Radio Company, Ltd., New York Branch Office - 430 Park Avenue (2nd Floor), New York, NY 10022, USA Tel: (212) 355-1180 / Fax: (212) 315-5227

Japan Radio Company, Ltd. - Akasaka Twin Tower (Main), 7-22, Akasaka 2-chome, Minato-ku, Tokyo 107, JAPAN Tel: (03) 3584-8836 / Fax: (03) 3584-8878

CIRCLE 78 ON READER SERVICE CARD

- Phase-lock ECSS system for selectable-sideband AM reception.
- Maximum IF bandwidth flexibility! The Variable Bandwidth Control (BWC) adjusts the wide and intermediate IF filter bandwidths from 5.5 to 2.0 kHz and 2.0 to 0.5 kHz—continuously.
- Stock fixed-width IF filters include a 5.5 kHz (wide), a 2.0 kHz (intermediate), and a 1.0 kHz (narrow). Optional JRC filters include 2.4 kHz, 300 Hz, and 500 Hz crystal type.
- All mode 100 kHz - 30 MHz coverage. Tuning accuracy to 1 Hz, using JRC's advanced Direct Digital Synthesis (DDS) PLL system and a high-precision magnetic rotary encoder. The tuning is so smooth you will swear it's analog! An optional high-stability crystal oscillator kit is also available for  $\pm 0.5$  ppm stability.
- A superior front-end variable double tuning circuit is continuously controlled by the CPU to vary with the receive frequency automatically. The result: Outstanding 106 dB Dynamic Range and +20 dBm Third-Order Intercept Point.
- Memory capacity of 200 channels, each storing frequency, mode, filter, AGC and ATT settings. Scan and sweep functions built in. All memory channels are tunable, making "MEM to VFO" switching unnecessary.
- A state-of-the-art RS-232C computer interface is built into every NRD-535D receiver.
- Fully modular design, featuring plug-in circuit boards and high-quality surface-mount components. No other manufacturer can offer such professional-quality design and construction at so affordable a price.



# Nation's Largest Shortwave Dealer



## SONY ICF SW33



Sony's latest portable, covering all 11 International S.W. bands plus AM and FM. Looking for a portable for your summer travels? This is it!

- 38 City Name, Time Display
- 17 Presets Memory
- Dual Wake-Up Station
- Tuning Steps SW 1kHz
- FM 76-108 MHz, MW 530-1710kHz
- 11 Shortwave Bands: 75, 60, 49, 41, 31, 25, 21, 19, 16, 13, 11 Meter Bands
- Power 4.5 VDC (3) AA (Not Incl.) Optional AC Adapter
- Antennas: MW Ferrite, FM/SW Telescopic
- Speaker 2.6", External Jack
- Size: 3.66"Hx5.3"Wx1.1"D Weight 15 Oz.

List \$219.95, EEB Introductory Price \$179.95 + s & H

### Radios & Scanners

AOR	JRC	SANGEAN
AR1000XLT .....\$429.00	NRD535 (1) ...\$1199.00	ATS800 .....\$99.95
AR3000A .....\$1029.00	NRD535D (1) ...\$1699.00	ATS803A .....\$179.95
AR2800 (3) .....\$429.95		ATS808 .....\$189.95
	<b>KENWOOD</b>	ATS818 (1) .....\$199.95
<b>BEARCAT</b>	RZ1 .....\$499.95	ATS818CS (1) ...\$229.95
BC200XLT (1) ...\$229.95	R2000 .....\$659.95	ATS606 .....\$159.95
BC760XLT (1) ...\$249.95	R5000 .....\$899.95	ATS606P .....\$179.95
BC800XLT (1) ...\$219.95		
	<b>LOWE</b>	
	HF150 .....\$599.95	
	HF225 .....\$749.95	
<b>DRAKE</b>	HF235 .....\$1995.00	
RB .....\$969.00		<b>SONY</b>
		ICFSW1S .....\$299.95
		ICFSW15 .....\$99.95
<b>GRUNDIG</b>	<b>MAGNAVOX</b>	ICFSW55 (1) ...\$349.95
SAT700 (1) .....\$449.95	1805 .....\$69.95	ICFSW77 .....\$469.95
	3625 .....\$99.95	ICFSW7600 .....\$219.95
		ICF2010 .....\$349.95
<b>ICOM</b>	<b>PANASONIC</b>	ICF7601 .....\$119.95
R1 .....\$459.95	RFB45 .....\$169.95	ICF7000 .....\$179.95
R100 .....\$619.95	RFB65 .....\$219.95	ICF7000 .....\$179.95
R71A .....\$1039.00		ICF7000 .....\$179.95
R72A (1,2) .....\$769.96	<b>REALISTIC</b>	
R7000 .....\$1219.00	PRO43 .....\$299.95	
R7100 .....\$1269.00	PRO2006 .....\$359.95	
R9000 .....\$4999.00	PRO2022 .....\$269.95	
	PRO46 .....\$189.95	<b>YAESU</b>
		FRG100 .....\$539.95

(1) New Lower Price (2) Limited Qty (3) New Item

## FRG-100 AWARD WINNER "BEST COMMUNICATIONS RECEIVER 1992"

Intro Price  
\$539.95

Plus EEB 1 Year  
Extended Warranty  
Free (\$59.95 Value).  
9.37x3.66x9.56 Inch  
6.6 lbs.



As awarded by the *World Radio TV Handbook* in their 1993 Radio Industry Awards. This is what they have to say about the new FRG-100. . .

*"Yaesu has succeeded in bringing improved technology and features within the price range of a much wider group of shortwave broadcast listeners. It has been a long time since Yaesu revamped their broadcast receiver but for many listeners it will be worth the wait!  
A good package at an affordable price."*

50KHz to 30MHz  
USB, LSB, AM, CW, FM Opt.  
Tuning Steps 10, 100, 1000Hz.  
Sensitivity CW/SSB .25µV.

4 Filters: 2.4, 4, 6kHz (.5 Opt).  
Dual Conversion 47.21 & .455MHz.  
Dual Ant Inputs 50 & 450 ohm.  
Power 11-14VDC 1.2A (AC Adapter Incl).

### FRG100HP EEB Improved Performance

EEB couldn't let this fantastic receiver go by without the high performance treatment. The major improvements come from up grading the filters. World famous Collins mechanical filters are used: .5, 2.4 and 6kHz. A ceramic 15 pole filter is used in the 4kHz position.  
(Opt. Collins CW Filter).....\$119.00

#### High Performance Package Includes:

1. Filter Upgrade (3 Filters)
2. 24 Hour Bench Test
3. Final Bench Test & Alignment
4. EEB Extended 1 Year Warranty

**FRG100HP \$749.95**

w/2 Year Warranty

#### 1. Passport To World Band Radio

The bible for SWL. . . all new for 1993 date on every SWL station, name, call, location, freq, power, target, language and more, plus test reports and over 90 SWL radios.  
416 pages .....(WBR93) \$16.95

#### 2. World Radio T.V. Handbook

Complete listing of all worldwide T.V. and SWL broadcast station. By country, time, freq, language, product review on the latest SWL radios  
550 pages (WRTVH93) ....\$19.95

#### 3. Scanner Modification Handbook Vol I

Complete instructions for cellular band restoration and many other modifications that will enhance scanner's performance. Covers PRO2004, 2005, 2006, 2021, PRO34, Bearcat, BC900XLT, 200/205 and 760.  
160 pages (CRB5) .....\$17.95

#### 4. Scanner Modification Handbook Vol II

Vol II has 18 more great enhancements for the same scanners in Vol I (above). Many modifications are adaptable to other scanners, photos, text, step by step for the average hobbyist.  
220 pages (CRB7) .....\$17.95

#### 5. Scanner Listener's Handbook

Hear more from your scanner. Lots of information put together for both the newcomer and old time scanner listeners. Freq breakdown, services, cross ref 25-2100MHz  
175 pages (T6) .....\$14.95

#### 6. How To Get Anything On Anybody

Called "Really Scarystuff" says Charles Jaco, CNN News, follow up of best selling Vol. I. 5 years in making exposes intelligence collecting, including never before published tricks, techniques, photos. Must reading.  
232 pages (HTGA).....\$35.00

#### 7. Tune In On Telephone Calls

Explains how persons with scanners can tune in on private phone calls, cellular and cordless phones, as well as other services.  
160 pages (CRB1) .....\$12.95

#### 8. Monitor America

The national communications guide. 2nd edition 822 pages. Most detailed and accurate guide ever written. 250 metro areas and resorts, state, federal and more. Has codes, unit ID, maps include railroad, aviation, car racing.  
822 pages (MA) .....\$24.95

#### 9. Complete SWL Handbook (3rd Ed)

Whether you're a beginner or a seasoned DX'er you need this book. Up-to-date info will make your SWL more meaningful and satisfying. Local, foreign, ships, aircraft, pirates, space shuttle, RTTY and more.  
294 pages (2655) .....\$17.95

#### 10. Shortwave Directory (7th Ed)

Revised DX'ers bible to 30MHz, including VLF. U.S. and foreign Air Force, Navy, Coast Guard, Army, energy, state, FBI, FCC, DEA, NASA, spies, smugglers. Glossary of terms heard on the air.  
270 pages (SWD) .....\$21.95

We accept VISA/MasterCard/American Express/Discover  
We ship via UPS, Federal Express & Mail

**ORDERS 800 • 368 • 3270**  
Local Tech 703 • 938 • 3350  
FAX 703 • 938 • 6911

Sorry no COD's  
Prices subject to change  
Prices do not include freight  
Returns subject to 20% restock fee



Electronic Equipment Bank  
323 Mill Street N.E.  
Vienna, VA 22180



# POPULAR COMMUNICATIONS

JULY 1993

VOLUME 11, NUMBER 11



4



46



52

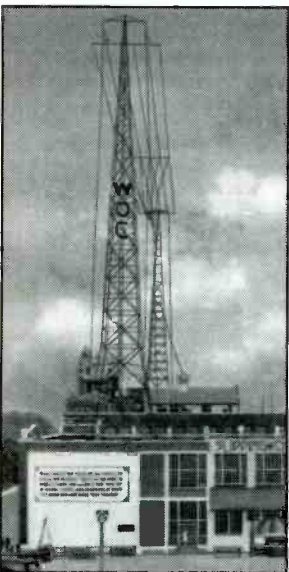

16

## FEATURES

### The Green Bank Telescope—DX'ing The Stars 9

A Follow-up On The Great Disaster of 1988  
By Kari Thurber, Jr., D.P.A., W8FXX

### Scanning The Marijuana Freeways 12

Our Interstate Highways Are Combat Zones In The War On Drugs! A Scanner Lets You Listen From A Safe Distance.

By Chuck Robertson

### The Secret Lives Of Call Letters 16

Many AM & FM Broadcast Stations Now Have Callsigns That Once Led Far Different Lives. Uncover Their Hidden Pasts & You'll Be Very Surprised!  
By Alice Brannigan

### Books You'll Like 22

The Telegraph, a Pirate Logbook, and a Guide To Ham Radio Satellites  
By R.L. Slattery

### Is It About Time For An Amateur Broadcasting Service? 39

Let's Have Your Opinions, Thoughts, and Ideas.  
By Harry Helms

## COLUMNS

Antennas 'n' Things .....	24
Communications Confidential .....	28
Washington Pulse .....	35
You Should Know .....	39
Scanning VHF/UHF .....	44
Broadcast DX'ing .....	46
Telephones Enroute .....	50
CB Scene .....	52
How I Got Started .....	57
Satellite View .....	58
RTTY .....	62
Listening Post .....	68
Emergency .....	74

## DEPARTMENTS

Beaming In .....	4
World Band Tuning Tips .....	40
New Products .....	61
Mailbag .....	73
Communications Shop .....	76

**This month's cover:** USA: The 140 foot radio telescope at the National Radio Astronomy Observatory at Green Bank, WV. Photo by Larry Mulvehill.

## EDITORIAL STAFF

Tom Kneitel, K2AES/KNY2AB, Editor  
Jeanine M. O'Connor, Associate Editor

## CONTRIBUTING EDITORS

Gerry L. Dexter, Shortwave Broadcast  
Robert Margolis, RTTY Monitoring  
Gordon West, WB6NOA, Emergency  
Don Schimmel, Utility Communications  
Edward Teach, Alternative Radio  
Harold A. Ort, Jr., Military consultant  
Janice Lee, Radar Detectors  
Chuck Gysi, N2DUP, Scanners  
Roger Sterckx, AM/FM Broadcasts  
Harry Helms, AA6FW, Thoughts and Ideas  
Donald Dickerson, N9CUE, Satellites  
Kirk Kleinschmidt, NTOZ, Amateur Radio  
Joe Carr, K4IPV, Antennas

## BUSINESS STAFF

Richard A. Ross, K2MGA, Publisher  
Donald R. Allen, N9ALK, Advertising Mgr.  
Emily Kreutz, Sales Assistant  
Dorothy Kehrwieler, General Manager  
Frank V. Fuzia, Controller  
Catherine Ross, Circulation Director  
Melissa Kehrwieler, Data Proc. Manager  
Carol Licata, Data Processing  
Denise Pyne, Customer Service

## PRODUCTION STAFF

Elizabeth Ryan, Art Director  
Barbara Terzo, Assistant Art Director  
Susan Reale, Artist  
Edmond Pesonen, Electronic Comp. Mgr.  
Dorothy Kehrwieler, Production Manager  
Emily Kreutz, Production  
Pat Le Blanc, Phototypographer  
Hal Keith, Technical Illustrator  
Larry Mulvehill, WB2ZPI, Photographer

A publication of



CQ Communications  
76 North Broadway  
Hicksville, NY 11801-2953 USA

Offices: 76 North Broadway, Hicksville, NY 11801.  
Telephone (516) 681-2922. FAX (516) 681-2926. Popular Communications, Inc. Second class postage paid at Hicksville, NY and additional offices. Subscription prices: Domestic—one year \$19.95, two years \$38.00, three years \$57.00. Canada/Mexico—one year \$22.00, two years \$42.00, three years \$63.00. Foreign—one year \$24.00, two years \$46.00, three years \$69.00. Foreign Air Mail—one year \$77.00, two years \$152.00, three years \$228.00.

U.S. Government Agencies: Subscriptions to Popular Communications are available to agencies of the United States government, including military services, only on a cash with order basis. Requests for quotations, bids, contracts, etc. will be refused and will not be returned or processed.

Entire contents copyright © 1993 by CQ Communications, Inc. Popular Communications assumes no responsibility for unsolicited manuscripts, photographs, or drawings. Allow six weeks for change of address or delivery of first issue. Printed in the United States of America.

Postmaster: Please send change of address to Popular Communications, 76 North Broadway, Hicksville, NY 11801.

# MONITOR MORE WITH ADVANCED EQUIPMENT FROM UNIVERSAL!

## COMMUNICATIONS RECEIVERS

### ● Japan Radlo NRD-535D



The deluxe "D" version with BWC, ECSS and three filters included. .... \$1699.00 (+\$18)  
NRD-535 standard version ... \$1199.00 (+\$16)

### ● Icom R-72A

This advanced receiver features 10Hz readout, 100 memories and more. .... \$899.95 (+\$11)

### ● Drake R-8

A state-of-the-art receiver for the 90's. Five bandwidths, Syncro., etc ..... \$959.95 (+\$11)

### ● Kenwood R-5000

A powerful receiver for the serious DXer. An exceptional value. .... \$899.95 (+\$12)

### ● Lowe HF-150 **NEW! Made in England.**

Finally ... a true portable communications receiver. Write for brochure. .... \$599.95 (+\$7)

## PORTABLE RECEIVERS

### ● Panasonic RFB-45



Keypad, 18 memories, scan and search functions, S.S.B., fine tuning knob, clock-timer, S-METER, etc. .... \$169.95 (+\$5)

### ● Sony ICF-SW77

Sony's finest! 94 alpha memories, dual clocks, sync. detection. .... \$489.95 (+\$6)

### ● Sangean ATS-818CS

Finally, a quality digital receiver with cassette, 45 mems., SSB. .... \$249.95 (+\$7)

### ● Grundig Satellit 700

Hi-tech with beautiful fidelity and style. Synchronous tuning. .... \$479.95 (+\$6)

*Note: Radios listed above are all LW-MW-SW-FM digital. Contact us for other models.*

## COMMUNICATIONS BOOKS

### ● Passport To Worldband Radio

By L. Magne. Graphic presentation of all SWBC stations. Equipment reviews too. .... \$16.95

### ● Shortwave Receivers Past & Present

By F. Osterman. Your guide to 200 receivers with new-used value, specs, features. .... \$8.95

### ● Aeronautical Communications Handbook

By R. Evans. A mammoth book on all aspects of shortwave aero listening. 266 pages. ... \$19.95

### ● Complete SWL's Handbook

By Bennett, Helms, Hardy. Nearly 300 pages on all aspects of SWL'ing. .... \$16.95

### ● Guide To Utility Stations

By J. Klingenfuss. The definitive guide to utility stations- CW, SSB, FAX and RTTY. .... \$36.95

### ● Easy-Up Antennas for Listeners & Hams

By E. Noll. Low cost, easy to erect antennas for LW, MW, FM, SW, SCAN and HAM. .... \$16.95

### ● World Radio TV Handbook

All SWBC stations by country with schedules, addresses, power, etc. Reviews too. .... \$19.95

### ● Discover DXing!

By J. Zondlo. An excellent introduction to DXing the AM, FM and TV bands. .... \$4.95

✓ Please add \$1 per title for shipping.

## MULTI-MODE CONVERTERS

### You can monitor:

- ◆ Coastal Station Tfc.
- ◆ Ship Telexes
- ◆ Press Reports
- ◆ Press Photos
- ◆ Satellite Photos
- ◆ Weather Maps
- ◆ Unclass. Military Tfc.
- ◆ Diplomatic Traffic
- ◆ Ham Messages
- ◆ Weather Reports
- ◆ Research Traffic
- ◆ Packet Messages
- ◆ Radio Bulletins

If you are only listening to your shortwave radio you are missing half the fun. With the addition of a Universal decoder and monitor you can see the world. The shortwave spectrum is filled with interesting text messages

and photos that you can intercept and display. If this sounds interesting to you, request our two free pamphlets: *Listening to Radioteletype* and *Receiving FAX on Your Shortwave Radio*. Shown above is the Universal M-900 (\$429.95) which decodes: Morse code, Baudot RTTY, Sitor A/B, FEC-A and FAX. Contact us today for information on the full line of Universal decoders.

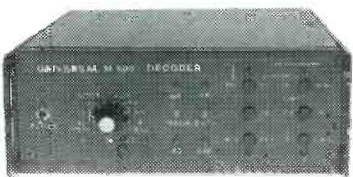

### ● Universal M-900

## CODE AND TONE READER

### ● Universal M-400



Forget the limitations you have come to expect from most "readers". The self-contained Universal M-400 is a sophisticated decoder and tone reader offering exceptional capabilities. The SWL can decode: Baudot, SITOR A&B, FEC-A, ASCII and SWED-ARQ. Weather FAX can also be decoded to the printer port. The VHF-UHF listener will be able to copy the ACARS VHF aviation teletype mode plus GOLAY and POCSAG digital pager modes. Off-the-air decoding of DTMF, CTCSS and DCS is also supported. Big two-line 24 character LCD. The M-400 can even be programmed to pass only the audio you want to hear based on CTCSS, DCS or DTMF codes of your choosing. The M-400 runs from 12 VDC or with supplied AC adapter. The American-made Universal M-400 is the affordable accessory for every shortwave or scanner enthusiast. Specification sheet available. Only \$399.95 (+\$6).

### ● Universal M-1000

Turn your IBM computer (or compatible) into a powerful intercept device! The Universal M-1000 Decoder Card requires just one full-size slot in your PC. Your computer can open up a new world of listening (... or seeing) opportunities! Standard reception modes are included such as Morse Code, Baudot RTTY and Sitor A/B. Advanced diplo-military modes such as ARQ-M2, ARQ-E and ARQ-E3 are supported plus ASCII and Packet. Advanced RTTY enthusiasts will appreciate the *Databit* and *Literal* modes, helpful in protocol identification and decryption. The video quality of your FAX intercepts will amaze you. Advanced FAX imaging includes false-color and zoom features. FAX images as well as text traffic can be saved on to disk. Operation is easy through on-screen menus, status indicators and help windows. A new *datascope* feature operates in both RTTY and FAX modes. This device merely requires audio from your receiver. The M-1000 comes with an informative manual and software on both 3½" and 5¼" disks. Upgradable for future optional codes. Six month limited warranty. Made in the U.S.A. Write for information. \$399.95 (+\$5)



- Universal ships worldwide.
- Prices and specifications are subject to change.
- Universal in business since 1942.
- Visa, Master & Discover Card.
- Used equipment list available.

## ★★★ HUGE FREE CATALOG ★★★

Universal offers a new communications catalog covering shortwave, amateur and scanner equipment. There are also antennas, books, parts and accessories. This informative 100 page reference covers everything for the radio enthusiast. With prices, photos and full descriptions.

Available FREE by fourth class mail or \$1.00 by first class mail.



**Showroom Hours**  
Mon.-Fri. 10:00 - 5:30  
Thursday 10:00 - 8:00  
Saturday 10:00 - 3:00

**universal radio inc.**

**Universal Radio, Inc.**  
6830 Americana Pkwy.  
Reynoldsburg, Ohio  
43068 U.S.A.

☎ 800 431-3939 Orders  
☎ 614 866-4267 Information  
☎ 614 866-2339 Facsimile



# 40 Years As The Best In Shortwave Radios And Now Ham Radio, Too!



**GREAT PRICES** Compare and Save!

**GREAT SERVICE** Our knowledgeable and courteous sales people are always happy to help!

**GREAT SHOWROOM** All receivers, antennas, books and accessories are on display and usable.

**A WIDE RANGE OF BRANDS:**

KENWOOD, YAESU, JRC, SONY,  
GRUNDIG, ICOM, AEA, KANTRONICS.

## GILFER SHORTWAVE

52 Park Ave., Park Ridge, NJ 07656  
(close to GS Parkway, NY Thruway, Rt. 80 and  
Rt. 287. Phone for directions and hours.)

201-391-7887

SENT \$1 FOR FIRST CLASS CATALOG

CIRCLE 64 ON READER SERVICE CARD

## NOW—NO CODE!

*The Ham Radio Handbook* by Don Stoner gets rave reviews as the best training aid to help you earn the no-code ham license. Over 200 pages, packed with information—all the test questions, correct answers and the theory behind the questions. Only \$9.95 (\$2.00 S&H).

## YOU CAN PASS THE CODELESS HAM RADIO TEST AND WE GUARANTEE IT!

It's easy and fun with the **NARA Education Package**. You get Don Stoner's *Ham Radio Handbook*, IBM or Macintosh compatible software to test your knowledge after you have studied the book; an extensive list of Volunteer Examiners you can contact, the *FCC Rules and Regulations* for ham radio, a copy of *Amateur Radio King of Hobbies*, plus a bonus copy of our journal, *The Amateur Radio Communicator*, by mail. The **NARA Education Package** is only \$29.95 for the IBM or \$49.95 for the Mac version (\$3.00 S&H).

**Join NARA today** and enjoy the exciting world of ham radio — and beginners don't need to know the code! A one-year **NARA** membership & subscription to *The Amateur Radio Communicator* is only \$10.00.

**NARA**  
NATIONAL AMATEUR RADIO ASSOCIATION

CALL US  
TODAY!!

P.O. Box 201407  
Arlington, TX 76007  
1-800-Got-2-Ham

CIRCLE 70 ON READER SERVICE CARD

# BEAMING IN

BY TOM KNEITEL, K2AES

## AN EDITORIAL

### Thoughts For A Summer Night

It's one of those summer nights when there's static on the shortwave bands and reruns on TV. A night when I wait until the wee small hours of the morning. I drag out that big old AM receiver, the one with all of the tubes, knobs, and the panel meters that read out things like microhenries and microjoules. I tune in some distant station, then take out the yellow pad to jot down assorted observations on the state of mass communications. I've devoted recent editorial space to Congressional frequency giveaways, the status of shortwave broadcasting, FCC activities, anti-scanner activities of the cellular phone industry, and like that. Yet, I keep telling myself that it's time again to scribble down some comments on domestic broadcasting. Now's that time.

For one thing, I notice that our language is changing. Yes, I know language changes with time, but these changes are just awful. They're on the ham and CB bands as well as broadcast frequencies, so I guess we are stuck with them.

I wince when I hear people mean, "I said to him," and yet it comes out, "I go to him." Of course, the reply from the other person is invariably described as, "So, he goes to me..." Why have people decided not to talk, but, instead, to "go"?

Can't understand where people have picked up the atrocious term "Alls I need..." Is there really a plural form of the word "all"? Why does anybody need one? I believe the mystery lies in the reason why some require a plural for the word "you." This word is "yiz," as in, "When will yiz be on the repeater again?"

Has anybody noticed the grotesque way use of the word "fun" has evolved lately? You can now use it in creative new ways. Very common on TV and in radio. Things are now "so fun," "very fun," "funner," and "the funnest." Fun? I'll tell you about fun! I've had plenty of fun my life, but nothing has yet happened that would permit me to tell about it in these terms.

What about people who want to describe a conversation they had. They announce, "I was like..." and then repeat the conversation. Why were they like something instead of simply telling you what they said? When you hear this, you should suspect you're dealing with a heavy hitter. I usually reply, "I was like confused." Let them deal with whatever that means.

People who freely toss around the terms "not a happy camper," "as it were," or "reference is made," soon become tiresome. Those who make an inquiry by prefacing



"Fun? I'll tell you about fun! I've had plenty of fun in my life..."

it with "Question:" eventually reveal themselves to be full-blown dweebs. These are excellent advance warning signals to rely upon, regardless of whether you encounter them on radio or TV, on ham or CB bands, or in person.

Other observations about TV and radio.

No matter what a TV reporter is sent into city streets to do a remote about, have you noticed that they never fail to be surrounded by a phalanx of laughing local area residents shouting, jumping, waving, and happily gesturing to the camera? Since the reporter is usually describing some horrible accident or crime, the reaction of the others on-camera makes me wonder why the reporter is so serious when the event is apparently being happily observed there in a carnival atmosphere.

Did you ever notice that network Special Bulletins never break into commercials, but freely interrupt programming? One wonders why the networks can't wait a few minutes and just add these bulletins to the natural storyline pause during a commercial break. I can't think of one I have witnessed in the past year or two that couldn't have waited a few minutes until the next commercial. At the very least, when the network interrupts a program with a bulletin they determine will interest you, they should stop running the program material during the bulletin and then resume it afterwards so the audience doesn't miss out on portions of a program.

Sometimes local TV stations are thoughtful enough not to break into programming with important bulletins. Instead, they put the information in lettering on a moving ribbon that travels across the screen from right to left while the programming continues. However, keep in mind that this moving banner of informa-

“ The R8 is a highly sophisticated receiver. We'd call it professional grade, or about as close to it as receivers get these days. ”

*Staff review  
Popular Communications*

“ The R8 is like a breath of fresh air, with its ground-up engineering and up-to-date digital control from the front panel. I am very pleased to see a quality HF receiver of American manufacture that should successfully compete on the world market. ”

*Bill Clarke  
73 Amateur Radio Today*



“ Overall, the Drake R8 is simply the best radio we have ever tested for quality listening to programs... ”

*There's nothing else quite like it. ”*

*Lawrence Magne  
Monitoring Times*

“ The best of the best for high-quality listening to news, music and entertainment from afar. ”

*Superb for reception of faint, tough signals, too. ”*

*Editor's Choice  
Passport to World Band Radio  
Tabletop Receivers for 1992*

# The ears have it!

When we introduced the American-made R8 Worldband Communications Receiver, we knew it would be judged by some very discerning ears, experts accustomed to the finest in short-wave listening equipment from around the world. After listening to the world on the Drake R8 loud and clear, they have delivered a decisive verdict.

They appreciated the R8's sensitivity, clarity, simplicity, and all-around versatility so much that many of them declared the R8 simply the best of its class. High praise, indeed, from very well-traveled ears.

But why take the word of mere experts? Put the Drake R8 to the test yourself with a 15-day money-back trial period on factory direct purchases, and let your ears be the judge. If you're not impressed by Drake's quality, performance and ease of operation, all in a receiver costing less than \$1,000.00, return the R8 Receiver within 15 days, and we'll refund your money in full, less our original shipping charge. To order your R8 factory direct, for more information, or for the dealer nearest you, call **1-800-937-2538** today. We're confident that once you've listened to the R8, your ears will hear of nothing else.



R.L. Drake Company  
P.O. Box 3006  
Miamisburg, OH 45343  
U.S.A.



In touch with the world.

CIRCLE 142 ON READER SERVICE CARD



tion has never notified you about anything important enough to be superimposed over a commercial.

Ultimately, with the exception of a tornado, severe thunderstorm warning, flash flood, or other emergency weather advisories, there are few things sufficiently urgent that can't wait a few minutes. They could hold off for a commercial break, or for a program to end, to break the news to the audience.

Speaking of TV commercials, has anybody noticed that so many of the new cars are being touted about their anti-lock brakes? These brakes are important because they can prevent the vehicle from going into a potentially dangerous spin. Yet, oddly enough, many car commercials on TV also seem strangely eager to show you the vehicle's lousy traction on a wet road surface. Car commercials show the vehicles spinning out, skidding sideways, and barely under control on wet surfaces. Amusing, but strange.

There are far too many cable channels. Some don't seem to have much reason to exist. And isn't it ridiculous that so many of them feel the need to almost continuously, or at least to the point of overkill, display their logos in the lower right corner of the screen? Very distracting. I can see a reason for using a logo while running proprietary news coverage, but it's preposterous to have to see this on the Sci-Fi Channel, CNBC, VH-1, The Family

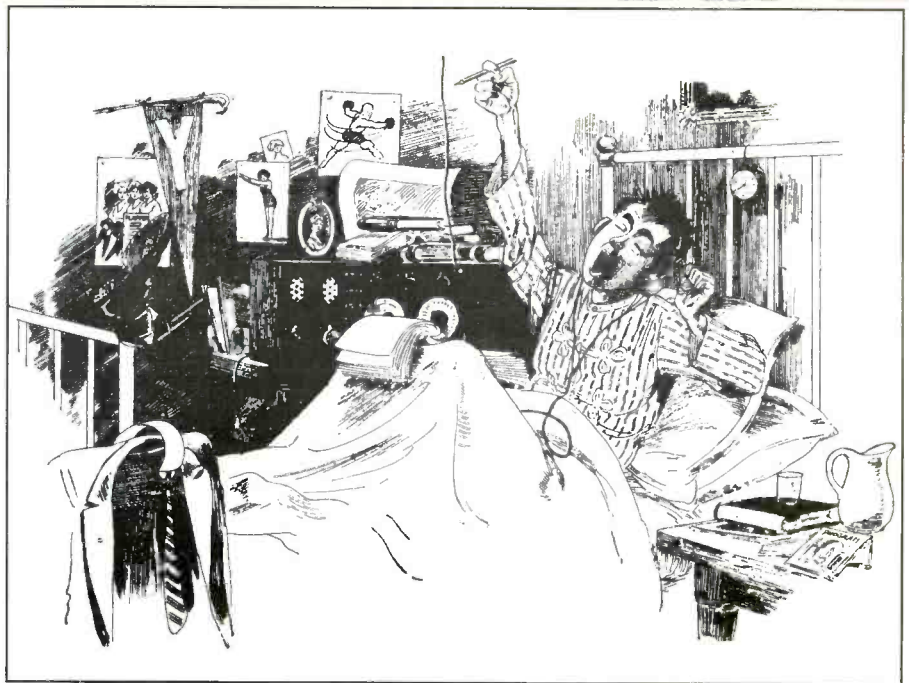

*"It's when I turn on the big old AM radio in the wee small hours and jot down some assorted observations..."*

Channel, USA, E!, and others. The logo on the "E!" channel is so large and bright that it draws your attention away from the programming.

What about all of the so-called celebri-

ties and stars that are fawned over on TV talk and tabloid shows? Donald Trump, Madonna, Michael Jordan, and Martina Navratilova are celebrities. Stars are people the caliber of Michael Jackson, Clint Eastwood, Liz Taylor, Robert De Niro, and Jodie Foster. Get it? But because every boob in North America now has their own TV talk show, these programs have become desperate for celebrity and star guests. As a result, second and third string TV talk and tabloid shows have created a genus of ersatz celebrities comprised of anybody who has ever taken a shot at someone, as well as the people they shot. To be introduced as a "star," a talk show guest can be someone whose biggest engagement was with the Marrakesh corn exchange.

Why do people in all food TV commercials need to make odd ecstasy faces when they taste the sponsors' products? Do sponsors think that's what you and I look like while partaking of their fried chicken, spaghetti sauce, candy, pizza, coffee, margarine, yogurt, cereals, fast food, and frozen low calorie dinners? I have yet to display anything beyond a poker face when sampling this stuff. OK, I'll own up to the time I sampled a frozen dinner. My look of shock, together with accompanying gasp, caused the poor cat to cough up a hair ball and send him hiding under the couch for two days.

Annoying TV commercials notwithstanding, I am buzzed by the lengthy interruptions in programming to periodically plead and beg for audience pledges to sup-

*(continued on page 72)*

## MICRO-CHOKE™ grabs those 800MHz signals you've been missing.

Antenna Specialists all-band scanner antennas, with our exclusive MICRO-CHOKE, offer pinpoint resonance at 800MHz and excellent performance from 25 to 1000MHz. Now—base or mobile—all police, fire, emergency and other FM communications (even portables) are within earshot. Start hearing more by sending for the FREE 16-page A/S Personal Communications Antennas catalog today!

**Tenfold signal improvement at 800 MHz!**

MON-53 Mobile Roof/Deck-Mount Antenna

MON-52 Mobile Trunk Lid Mount Antenna

MON-58 Base Station Antenna

**the antenna specialists co.**  
 30500 Bruce Industrial Parkway • Cleveland, OH 44139-3996  
 TEL: 216/349-8400 • FAX: 216/349-8407

© Copyright 1990 by The Antenna Specialists Co.

a member of The Allen Group Inc.



W R T H  
BEST RECEIVER 1992

## Don't wait for "film at eleven"!

### Introducing the award-winning FRG-100 Communications Receiver.

Why wait for someone else to tell you what's happening in the world when you can find out first hand?

Have all the hottest news – not just "bits". Listen to music pulsating through Europe. Monitor economic trends in industrialized nations. Eavesdrop on Third World country survival efforts. Track vital crisis developments during conventional communications breakdowns. Or "drop in" to your old neighborhood – even if it's 12 time zones away.

The FRG-100 is loaded with technical advancements like industry-exclusive adjustable SSB carrier offset and user selectable 10Hz,

100Hz or 1 KHz tuning steps. The exciting Broadcast Band mode with 16 pre-programmed international broadcast bands. 50 Memory Channels and twin 12/24 hour clocks to keep you tuned in where and when you like day or night!

Consistent with Yaesu's world-renown reputation for radio communications achievements, the FRG-100 won the prestigious *World Radio TV Handbook* award for "Best Communications Receiver" upon its introduction in December, 1992. But you're the *real* winner! Priced lower than receivers costing much more but with fewer features, the FRG-100 delivers extraordinary and affordable performance. Ask about the FRG-100 and it's remarkable low price at your Yaesu dealer today. Make up your own mind about world events. Find out first hand!

# YAESU

*Performance without compromise.*



VFO 11845.00 50CH AM

YAESU  
COMMUNICATIONS RECEIVER FRG-100

POWER

6dB ATT 12dB

VFO /MEM

MEM CLEAR

VFO MEM

MEM VFO

LOCK

NB AGC-F

CLOCK

TIMER

SEL

SET

DIM

PHONES

DOWN

MEM

UP

SQL

VOL

SSB

CW/N

AM/N

FM

© 1993 Yaesu USA, 17210 Edwards Rd., Carritos, CA 90701 (310) 404-2700  
Specifications subject to change without notice. Some accessories and/or options are standard in certain areas. Check with your local Yaesu dealer for specific details.

CIRCLE 92 ON READER SERVICE CARD





"The Largest Dealer of Scanners in the World"

# SCANNER WORLD, USA®

10 New Scotland Ave., Albany, NY 12208 • 518/436-9606

## SCANNER WORLD EXCLUSIVE

### UNIDEN BEARCAT BC205XLT

**\$239.99** (\$8.00 shipping)

Digital programmable 200 channel hand held scanner with raised button keyboard for easy programming of the following frequency ranges: 29-54 MHz, 118-174 MHz, 406-512 MHz, 806-956 MHz. Features include: Scan delay, memory backup, key pad lock, sidelit liquid crystal display, channel lockout, 10 twenty channel banks, direct channel access, automatic search, full one year factory warranty, 10 priority channels, Ni-Cad battery pack, AC adapter/charger, flexible rubber antenna carry case are all included. Size is 2-11/16" W x 1-3/8" D x 7-1/2" H. (Optional extended 2 yr. warranty \$29.99, 3 yr. extended warranty \$39.99) (\* Excludes Cellular)

#CC-008 Heavy Duty Leather Carry Case \$27.99

### RELM RH-256NB HIGH BAND TWO-WAY RADIO



**SPECIAL PACKAGE DEAL \$339.99**

(Plus \$9.00 Shipping Each)

16 channel digital readout two-way radio. Covers high band frequency range of 148-162 MHz without retuning. Perfect two-way radio for ambulance, police, fire, tow trucks, taxis, commercial companies who use this band. Features include CTCSS tones built-in, priority, 25 watts output, channel scanning, back lighted keyboard, message light, time out timer, scan delay, external speaker jack. Size is 2 3/4" H x 6 7/8" W x 1 1/4" D.

**SPECIAL PACKAGE DEAL** includes RH-256NB mobile microphone, 1/2 wave body mount antenna, mobile mounting bracket and mobile power cord all for the low price of \$339.99

### SPECIAL!! LOWEST PRICE EVER FOR A PROGRAMMABLE SCANNER



SR-901 AVAILABLE ONLY FROM SCANNER WORLD



**ONLY! \$74.99** Each

(Plus \$6.00 Shipping Each)

**\$69.99** (2 or more)

Features include: 10 programmable channels, one touch memory programming, external speaker jack, 29-54 MHz, 136-174 MHz, 406-512 MHz, squelch, lockout, full frequency digital readout, AC or DC operation, retains memory up to 3 days without power, scan button, includes AC adapter, telescopic antenna, and complete operating instructions. Size: 7 1/4" W x 2 1/4" H x 7 1/4" D. One year factory warranty. (Optional mobile cigarette lighter cord #901MPC \$4.99)

### UNIDEN MR 8100A



**SPECIAL SALE PRICE \$289.99**

ONLY (\$10.00 Shipping Each)

100 channel digital programmable mobile scanner. Turbo scan up to 100 channels per second, lockout, priority, built-in automatic 2 second delay, dimmer control, back lighted keyboard, track tuning, direct programming of frequencies from front keyboard plus you can also program MR 8100 from your IBM compatible PC computer with software and cables included with scanner from Scanner World. Frequency coverage: 29-54 MHz, 118-174 MHz, 406-512 MHz, 806-956 MHz. Dimensions: 7.9" W x 5.8" H x 1.9" D. Earphone jack, BNC antenna jack, DC power cord, mobile mounting bracket, internal memory backup, bank scanning; 10 banks of 10 channels in any combination.

MODEL: FB-911

### FIRE BOX PHONE

**\$45.99**

(\$5.50 Shipping Each)



13 memory phone, 3 direct access emergency memories, auto redial, ringer on/off, top light flashes when telephone is ringing, tone/pulse switchable, desk/wall mount, front door closes for authentic fire box appearance, FCC approved. Size: 16" H x 8 1/2" W x 7" D.

## RADIO SCANNERS

BEARCAT BC55XLT	99.99	(7.00)
BEARCAT BC70XLT	129.99	(7.00)
BEARCAT BC100XLT	159.99	(7.00)
BEARCAT BC142XL	75.99	(6.00)
BEARCAT BC148XLT	104.99	(7.00)
BEARCAT BC200XLT	279.99	(7.00)
BEARCAT BC205XLT	239.99	(8.00)
BEARCAT BCT2	149.99	(7.00)
BEARCAT BC400XLT	99.99	(7.00)
BEARCAT BC560XLT	109.99	(7.00)
BEARCAT BC760XLT	269.99	(7.00)
BEARCAT BC800XLT	214.99	(8.00)
BEARCAT BC855XLT	186.99	(8.00)
BEARCAT BC950XLT	249.99	(7.00)
COBRA SR901	74.99	(6.00)

MIDLAND CB Radios	In Stock
COBRA CB Radios	In Stock
UNIDEN CB Radios	In Stock
Two-Way Radio Batteries	In Stock
Scanner Antennas	In Stock
Power Supplies	In Stock

## SCANNER ACCESSORIES

BCAD70	14.99	BP4	24.99
BCAD100	14.99	BP55	16.99
BCAD140	14.99	MA917	24.99
BCAD 580	16.99	MA518	14.99
BC003	7.99	ESP25	16.99
BC002	59.99	GRE8002	79.99
PS001	12.99	GRE-HH	54.99
UA502A	12.99	GRE9001	89.99
BP205/200	34.99	GRE 3001	62.99
BP70	16.99	FBE	5.99
VC001	12.99	FBW	5.99

★ ALL MERCHANDISE NEW, IN FACTORY SEALED CARTONS

## BOOKS

Scanner Master	29.95
Covert Intelligence	8.95
Air Scan Directory	14.99
Betty Bearcat	5.99
Top Secret (7th)	15.99
Covert Techniques	9.95
Tomcat's Big CB	13.95
World Radio	18.99
Survival Directory	6.95
Rail Scan	7.95
Police Call	8.69
Scanner Modification	17.99

### UNIDEN BEARCAT BC-400XLT



**\$99.99**

(\$7.00 shipping)

Our best selling mobile scanner. 16 channel AC-DC programmable digital, AC-DC cords, telescopic antenna, mobile mounting bracket, weather search priority. 29-54 MHz, 136-174 MHz, 406-512 MHz, external speaker and antenna jacks.



### BEARCAT BC-100XLT

100 Channel Digital Programmable Hand-Held Scanner

**\$159.99**

(\$7.00 shipping)

Our best price ever on a full featured complete package hand-held scanner. Manufactured by Uniden. Features include 11 bands of weather, aircraft, public service, trans, marine, plus more (29-54 MHz, 118-174 MHz, 406-512 MHz), 10 channel banks, 10 priority channels, lighted LCD display, earphone jack, channel lockout, AC/DC operation, scans 15 channels per second, track tuning. Special package deal includes following accessories: AC adapter/charger, rechargeable Ni-Cad battery pack, flexible rubber antenna, carry case.

### UNIDEN BEARCAT BC-142XL

10 Channel Base/Mobile Programmable Scanner



**\$75.99**

(\$6.00 shipping)

Programmable, digital, AC or DC operation, weather button, priority, lockout button, squelch, memory backup, 2 digit LED display, track tuning, 2 second built-in delay. Frequency coverage 29-54 MHz, 136-174 MHz, 406-512 MHz. Sizes 9" x 6 1/2" x 2 1/4". Includes AC adapter and telescopic antenna. (Optional Cigarette Lighter Cord #142MPC. \$4.99)

### Bearcat BC-148XLT

16 channel with Automatic Weather Alert (similar to BC-142XL).

**\$104.99** (\$7.00 shipping)

### UNIDEN BEARCAT BC 800XLT



DIGITAL BASE SCANNER

**\$214.99** (\$8.00 Shipping)

Receive police, fire, ambulance, cordless phones, marine, trains, weather, ham, stock cars, public service plus much more. Frequency coverage 29-54 MHz, 118-174 MHz, 406-512 MHz, 806-954 MHz (continuous), 40 channels, AC/DC operation, digital programmable, memory backup requires 2 AA batteries (not included), telescopic antenna included, AC power cord included, external speaker jack, external antenna jack. Dimensions: 9 1/2" D x 4 1/2" H x 12 1/2" W. Channel lockout, direct channel access, scan delay, priority, digital display, auto weather button, automatic search, track tuning.

### UNIDEN BEARCAT BC-950 XLT

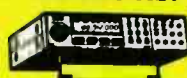

**\$249.99** (\$7.00 shipping)

Digital Programmable 100 Channel Scanner

BC-950 XLT covers the following frequencies: 29-54 MHz, 118-174 MHz, 406-512 MHz, 806-954 MHz (excludes cellular). Features compact size of 6-5/16" W x 1-5/8" H x 7-3/8" D, scan delay, priority, memory backup, channel lockout, bank scanning, key lock, AC/DC power cords, telescopic antenna, mounting bracket supplied, one year factory warranty, search, direct channel access, track tuning, service search including preprogrammed frequencies by pushing a single button for police fire/emergency, aircraft, weather, and marine services plus exclusive optional features never available on any scanner before. First is an RF receive amplifier for boosting weak signals for only \$34.99 plus a CTCSS tone board is available for only \$59.99 to make this the number one scanner available in the USA. Optional cigarette lighter plug #950 MPC \$4.99.

### GM-1™ GLASS MOUNT SCANNER ANTENNA

Frequency coverage 25-1200 MHz — only 22 inches tall — No holes to drill — Includes contact glue pads for easy installation. Complete with 17 foot cable, Motorola connector and mounting hardware. — Swivels to vertical position — performance unaffected by moisture on the window. Made in USA.



**SPECIAL**

**\$39.99**

(\$4.00 Shipping Each)

### GLASS MOUNT ANTENNAS FOR TRANSCEIVERS

Includes mounting kit and cable. Low Band, High band and UHF band include PL259 connectors. 800 cellular band antenna includes TNC connector.

GM-27 27 MHz Low Band for CB	\$39.99 (\$4.00)
GM-155 144-174 MHz High Band	\$39.99 (\$4.00)
GM-450 450-470 MHz UHF Band	\$39.99 (\$4.00)
GM-800 Cellular Telephone Band	\$34.99 (\$4.00)

**ORDERING INFORMATION:** Call (518) 436-9606 to place orders or mail orders to Scanner World, USA, 10 New Scotland Ave., Albany, N.Y. 12208. Orders will be shipped within 24 hours by United Parcel Service if order is accompanied by MasterCard, Visa, cashier's check, money order. COD (COD shipped by United Parcel Service will be cash or money order only). (If a COD package is refused, customer will be billed for shipping and COD charges.) Mail orders with personal or business checks enclosed will be held 4 weeks for bank clearance. Prices, specifications, and terms subject to change without prior notice. If items are out of stock we will backorder and notify you of delivery date. All shipments are F.O.B. Scanner World's warehouse in Albany, N.Y. We are not responsible for typographical errors. All merchandise carries full manufacturer's warranty. Bid proposals and purchase orders accepted from government agencies only. Free full line catalog mailed 4 times per year. Merchandise delivered in New York State add your local sales tax. No returns accepted after 7 days of merchandise receipt. \* Add (\$5) per item, and \$3.50\* for all accessories ordered at same time. COD orders will be charged an additional \$4.95 per package. Full insurance is included in shipping charges. All orders are shipped by United Parcel Service to street address only. (No P.O. Box). Shipping charges are for continental USA only. All others ask for quote on shipping charge.

Scanner World, USA® • 10 New Scotland Ave., Albany, NY 12208 • 518/436-9606



# The Green Bank Telescope— DX'ing the Stars

## A Follow-up On The Great Dish Disaster Of 1988

BY KARL T. THURBER, JR., D.P.A., W8FX

**W**here were you on the evening of Tuesday, November 15, 1988? If you're a radio astronomer, you know that on that date the 300-ft. diameter, 78,000 square foot radiotelescope dish at the National Radio Astronomy Observatory (NRAO) Green Bank, West Virginia site collapsed. While no one was injured, the failure also collapsed a lengthy list of research proposals to put a crimp in America's radio astronomy research program and its capability to probe deep space. It's a crimp that won't be overcome until a new instrument is ready in 1995.

This article is about the new Green Bank Telescope (GBT), which will be the largest steerable radiotelescope in the world when completed. Leading up to its construction was the 1988 disaster, when the 300-ft. dish collapsed. Included is a discussion of the telescope's background and mission, reasons why the old telescope failed, and the new telescope's future.

### A Little Background

The failed telescope was in a sparsely populated area shielded by mountains from most radio interference, letting it capture the faint signals emitted naturally by extraterrestrial objects. First used in September, 1962, it was built for \$900,000; a more accurate, \$500,000 surface was put on in 1970. NRAO is operated by the nonprofit Associated Universities, Inc. (AUI), for the National Science Foundation (NSF).

The 300-foot telescope was the largest

in the United States and one of the most powerful in the world: it could survey the entire northern sky. In fact, it was capable of listening to stellar objects billions of light-years away. The dish was a parabolic-shaped bowl 300 feet in diameter with an aluminum mesh surface supported by a steel backup structure on two 87-foot steel towers. The telescope had an area of 78,000 square feet (about 1.8 acres), and its moving total weight was about 500 tons. The surface reflected radio waves and focused them to a point 225 feet above ground, where they were intercepted and sent down cables to the control building.

The telescope was operated 24 hours a day, every day, except for maintenance and holidays. The instrument was open for any qualified scientist. In a typical year, about 50 astronomers used the telescope for projects that ranged from the study of relatively nearby clouds of interstellar gas to the study of very distant objects. Since 1962, more than 1000 astronomers used it to study galaxies, quasars, stars, pulsars, the sun, and the planets. The most complete surveys of cosmic radio sources were made by it.

One of its most famous discoveries was that the gas in a galaxy such as the Milky Way could occupy a much larger volume than the stars, and could even form a bridge through intergalactic space to connect with another galaxy. The telescope also discovered a rapidly pulsating radio source in the Crab nebula, the remnant of the star that exploded to create the spectacular nebula,

to help unlock the puzzle of the pulsars as the logical products of stellar evolution.

### D-Day: November 15, 1988

*The Disaster.* At 9:43 p.m. on November 15, 1988, the 300-foot dish collapsed. The disaster reverberated throughout the scientific community as the loss affected a long list of research projects aimed at picking up the faint, super-DX (distant) radio signals emitted by various objects and radio sources. At the time it collapsed, the telescope was mapping the northern sky in search of quasars and other sources of radio waves, and it was soon to begin studying the magnetic field in the Milky Way.

Although the collapse of the 300-foot instrument was a major scientific loss, it was only one of five telescopes operated by the NRAO. The others included a smaller, 140-foot telescope at Green Bank; the 12-m., millimeter-wave telescope on Kitt Peak near Tucson, Arizona; the Very Large Array instrument, an array of 27 antennas, each 25-m. in diameter, west of Socorro, New Mexico; and the Very Long Baseline Array, an under-construction array of 10 antennas, each 25-m. in diameter, located at several sites. Fortunately, the 140-foot Green Bank telescope was not of the same construction and was not affected by the disaster. The two were of different design and served different needs.

*How and Why?:* Stress loads led to the disaster. The collapse likely resulted from the fracture of a single high-stressed steel

plate, according to a panel appointed by NSF and AUI.

The 300-ft. telescope was built at minimum cost over 2 years according to then-current engineering standards. It was expected to have a useful life of about 10 years, but because an updated telescope wasn't built, the 300-footer remained in operation until its collapse.

Investigators concluded that the collapse was not the result of poor maintenance or improper operation. A metallurgical analysis suggested that the fractured plate, which joined the dish support structure to the bearing near the top of one of the two towers, broke in two where small cracks had been developing for years. The cracks, due to fatigue brought about by high stress loads—especially while the telescope was moving—were obscured by other structural elements and remained undetected during routine inspections. According to a computer stress analysis, the plate's sudden failure was sufficient to cause the entire telescope to collapse. The telescope failed while the dish was being moved from one position to another.

## The New Green Bank Telescope

Fortunately, a replacement is on the horizon. The new GBT, to be ready in 1995, will be the world's largest fully steerable radio telescope. It will be useful over a much greater band of radio wavelengths than any telescope of comparable size—from several meters (a few feet) to several millimeters (about 1/10"). Under laser control, the GBT will have a pointing accuracy approaching 1 second of arc, about the angle subtended by a dime when seen from a distance of one mile. Considering the previous experience, the new GBT will be subjected to wind tunnel testing.

Users will come from universities and laboratories around the world. Their proposals will be reviewed by their peers, whose ratings will determine which proposals compete successfully for available telescope time. The instrument will be in use at all hours, day and night, every day of the year. If radio astronomy's past is a valid predictor of its future, the new tele-

scope will discover objects and phenomena that we can't predict today.

## Technical Details On The Telescope

The National Radio Astronomy Observatory (NRAO) has been a center for radio astronomy research since 1958. The Green Bank Telescope, or GBT, ushers in a new era for cosmic research. Since most of the telescope's lifetime will be spent in the 21st century, its precise scientific mission can't be predicted. But the design emphasizes versatility: the GBT itself will be capable of continuous improvement throughout its lifetime.

## Goals for the Green Bank Telescope

**High sensitivity.** The GBT will have an immense collecting area, a clean beam, and low-noise electronics combining to produce an unprecedented ability to detect weak signals.

**A greater wavelength range.** The primary mirror will be adjusted continuously to maintain a parabola accurate enough for receiving radio waves only millimeters in length.

**Wide sky coverage.** The telescope's full steerability will provide access to eighty-five percent of the sky.

**Greater versatility.** A suite of receivers and detectors can, in minutes, be interchanged in response to reprioritized scientific opportunities and weather changes.

**Good discrimination against interference.** No structures block the main reflector; their absence eliminates scattering of signals into the path of the radiation being observed.

**High resolving power.** Electronic and computer links will connect the telescope to other sensors, including those in earth orbit, to sharpen the angular detail that can be revealed.

## Key Specifications of the GBT

The GBT's primary reflector dimensions will be 100 x 110 meters, for an aperture of 100 meters and a focal length of 60

meters; the subreflector is 7.55 x 7.95 meters. The instrument is useful over an azimuth range of -270 degrees to +270 degrees and an elevation range of 5 degrees to 95 degrees. It will have a surface accuracy of as little as 0.22 mm. and a pointing accuracy as small as 2". The telescope's moving weight is 14,000,000 lbs.

## Conducting Fundamental Science with the GBT

**Investigating the structure of interstellar space.** Surveys of hydrogen emission from distant galaxies will help map the distribution of matter in the universe.

**Examining the nature of time.** Precision timing of rapidly spinning pulsars can help test predictions of Einstein's General Theory of Relativity.

**Studying the chemistry of space.** The many molecules that occupy the spaces between stars in the Milky Way and other galaxies can be studied by the sharp signal each radiates.

**Seeking out the origin of space time.** The "radio hiss" filling interstellar space since the beginning of time can be mapped for hints as to the seeds from which galaxies developed.

**Probing energy sources.** Violent activity at the hearts of galaxies and quasars can be monitored and probed in search of evidence for the existence of black holes and other phenomena.

**Conducting a census of the radio universe.** The GBT can rapidly scan the sky, detecting and mapping hundreds of thousands of radio sources billions of light-years from our galaxy.

## Unique Features of the GBT

**An unblocked aperture.** The arm supporting the receivers at the focal point is outside the path of incoming radiation. Thus, few extraneous signals are scattered into the receivers so that most of the energy they accept comes from astronomical objects.

**An adjustable surface.** Each of the instrument's 2204 panels can be moved in or out by computer controlled actuators, eliminating distortions of the dish surface.

**A precision pointing capability.** Lasers on the telescope beamed at reflecting cubes on its surface determine its shape to a tenth of a millimeter, while lasers on the ground circling the telescope determine where it's pointing to a few seconds of arc.

**Selectable receivers.** One receiver can be swung into position at the prime focal point; or a receiver on a turntable at the secondary focal point can be rotated into position.

*About the author: Dr. Karl Thurber has been writing electronics, computer, and amateur radio articles since the mid-1970s. He is a contributing editor and monthly columnist for CQ, the premier publication for amateur radio operators. He's also the author of articles in ComputerCraft, Popular Electronics, Radio Electronics and other leading industry publications.*

Need a GREAT-sounding, ULTRA-RELIABLE, SOLIDLY-made long play recorder? TIRED of POOR-sounding, FLIMSY recorders?

Why spend over \$100 for a long play recorder "improvised" from a plastic "consumer-type"? Spend a few more \$\$ and get the BEST!

**PROFESSIONAL 10 HOUR RECORDER.** Built like a **BATTLESHIP**



- \* Special Pop/Comm price \$139
- \* BUILT-IN voice activation (NO box dangling outboard) add \$25
- \* Automatic telephone adaptor, FCC approved, ONLY \$16
- \* Dialed number decoder, reads numbers from tape \$59

No shipping charges on prepaid orders. COD's OK. Cal. residents add tax. Sorry, no credit cards (all they "do" is increase prices--)

FREE info for reader service card requests. FREE 36 page catalog if requested by phone/tax/letter



**VIKING INTERNATIONAL**  
SINCE 1971  
150 EXECUTIVE PARK BLVD. #4600  
SAN FRANCISCO, CA 94134  
PHONE: (415) 468-2066  
FAX: (415) 468-2067

CIRCLE 77 ON READER SERVICE CARD



# The Fastest Counter Starts with the Fastest Chip

## Optoelectronics Puts the OE10 Inside

Since the 70's the frequency counter chip most used was the 7216 (8 digits,



10 million counts per second). The only way to have a faster more reliable counter was to design our own chip. So we did —

the OE10. Faster — 10 digits, 220 million counts per second. Reliable — zero field failures.



## And now we have added a microprocessor to unleash the power of the OE10.

Optoelectronics introduces the 3000A Multifunction Micro HandiCounter<sup>®</sup> with these new and exciting features:

- **Digital Filter Technique** (patent pending)  
Filters stable signals from background clutter
- **Digital Auto Capture** (patent pending)  
Holds present reading and stores previous reading for hands free unattended operation
- **Works Even in Presence of Strong RF Signals**
- **Stores Frequencies**
- **Increased Sensitivity**
- **Synchronous RF Detection**  
Super sensitive 16 segment bargraph operates independently from counter
- **High Speed ASIC**  
220 million counts per second.
- **10Hz-3GHz**
- **Multifunction HandiCounter<sup>®</sup>**
- **Dual High Impedance Amplifiers**  
For ratio and time interval functions
- **High Resolution**  
Direct count to over 200MHz
- **Extended Battery Use**
- **1 Year Full Warranty**
- **All This and More for the Low Price of \$279.**

### Options for the NEW 3000A

- TCX030  
± .2ppm .....\$100.
- BL30/Backlight .....45.
- Antenna - TA100S  
Telescoping Whip Antenna .....12.
- Antenna Pack 2  
Includes RD27, RD50, RD100  
RD440, RD800 - Save \$32.....99.
- CC30  
Padded black vinyl carrying case .....15.

### Factory Direct Order Line

**1-800-327-5912**

305-771-2050 • Fax 305-771-2052

5821 NE 14th Ave, Ft. Lauderdale, FL 33334

5% Ship/Handling (Max \$10) U.S. & Canada. 15% outside continental U.S. • Visa, Master Card, C.O.D. (Cash or Money Order only).

**OPTOELECTRONICS**  
**BE SURE YOU HAVE AN OE10 INSIDE**

# Scanning The Marijuana Freeways

**Our Interstate Highways Are Combat Zones In The War On Drugs! A Scanner Lets You Listen From A Safe Distance.**

BY CHUCK ROBERTSON

**N**ow, more than ever before, state troopers and sheriff's deputies are patrolling the US Interstate highway system looking for narcotics couriers. Their efforts have proven to be worthwhile. Stats show that drug, cash, and vehicle confiscations on the Interstates have reached an all-time high. For police, it was like finding the Big Rock Candy Mountain.

Perhaps not well-known, but the zero-tolerance drug laws passed during the Reagan era permit money and property to be confiscated based solely upon probable-cause that a drug crime has taken place, or will take place. For instance, if a driver has more than \$1,000 in cash, it could be assumed that the money is to be used for a drug purchase. A large amount of cash is, in itself, probable cause to suspect criminal activity.

In effect, it's the property that is being arrested. Property possesses no human rights, so it's not necessary to prove that a crime has or would have taken place. No trial by jury is required.

The property owner, in some cases, has as few as twenty days to file for return of the seized materials. Otherwise, it is automatically forfeited and divided up among the agencies involved in the confiscation. To agencies feeling the pinch of budget constraints, this has been a boon, and the agencies are all within their legal rights.

In about 80% of all federal money/property confiscation cases, no criminal charges are ever brought against the property owner. In Florida, it runs at 75%, and confiscations include luxury yachts and limos, trucks, aircraft, and charter boats. If it's suspected that a vehicle has been used in drug trafficking, it may be confiscated at any time within eight years of the alleged incident—no matter how many times it's been legally resold as a used car since then.

This has helped turn the Interstates into that war zone.

## Cat & Mouse

Interstate highways are the pipelines often used for drug shipments. Couriers head for the Gulf or Mexican border areas



*Interstate highways crisscross the continent. Heavily used by tourists and truckers, they are equally convenient for drug couriers.*

to pick up loads of drugs such as cocaine or marijuana. Then they truck their cargo towards final destinations like Chicago.

One popular method of courier operation is to arrange for several "drops" along their route. Setting up temporary offices at motels near the Interstates, they use pay phones to arrange for local sales. After a few days, they move on to another community along the line.

Recently, Illinois State Police detectives were noted on 154.95 MHz while staking out a courier operating from a motel near I-57 at one of the Marion exits. After a couple of days of following him around to pay phones and delivery points, they made their arrest. Motel personnel helped the police. It made for great listening.

High on the suspect vehicle list are long-haul semi-tractor trailers, commonly known as "18-wheelers." Although the majority of the thousands of semi-trailers that travel the Interstates daily are perfectly legit, police feel the need to look for those that might be hauling drugs. Semis that travel between drug cities come under particular scrutiny. At weigh stations, or when

they are pulled over for routine inspections or a traffic violation, they might get checked out by drug-sniffing dogs.

## Business As Usual

Police often use profiles of typical drug couriers to help them in determining which cars and drivers are more likely than others to be transporting contraband along the Interstates. As has been reported on national TV, and in several books, these profiles involve several factors, including ethnic considerations, especially in combination with certain out-of-state license plates. The practice has had its strong critics, to be sure. Yet, it remains in popular use in many areas.

Suspicious vehicles may be pulled over and the drivers questioned. Perhaps the vehicle will be searched, the driver given a warning ticket, and then let go. I spoke to several drivers at a fast-food place near I-57. They complained that they all fit a courier profile, and had been stopped by police several times. Unfortunately, they were all still a long way from home.



### On-The-Road Frequency Sampler

**Accident Reconstructive Lab**, Dallas, TX: 463.975  
**Alcoholism Residential Car Authority**, Winston-Salem, NC: 464.90  
**American Motorcycle Assn.**, Westerville, OH: 467.85, 469.50  
**American Speed Assn.**, USA: 469.50, 469.55  
**Auto Busters**, Ft. Pierce, FL: 150.89  
**Auto Recovery Bureau**, Columbia, SC: 151.745  
**Automotive Adventures**, USA: 151.625  
**Baja Motorsports**, USA: 462.8125  
**Boarder Inns of America**, Mallen, TX: 154.57  
**Cannonball Express**, Omaha, NE: 151.925, 159.54  
**Caution, Inc.**, Nashville, TN: 151.625  
**Citizens Aid Radio**, Troy, MI: 463.625  
**Collision World**, Kensington, CT: 35.10  
**Dogs Against Drugs Int'l.**, Palm Beach, FL: 464.05  
**Exit 0, Inc.**, USA: 464.55  
**Fast Lane Trans.**, Montros, CA: 462.10 467.825, 467.925  
**Florida Crime Control**, Miami, FL: 463.425  
**The High Plains Drifter**, Albuquerque, NM: 464.50  
**Highway Alert Team of Mass.**: 462.65  
**Highway Ministry**, NY/PA: 151.925  
**Highway Patrol Svc.**, Metairie, LA: 151.955  
**Highway Rescue**, Rawlings, WY: 122.9, 123.1  
**Highway Safety of Tenn.**: 461.075, 461.575, 463.65, 464.95  
**Highway Traffic Control**, Wadsworth, OH: 151.625  
**Hit & Run Safety Systems**: 457.525, 457.60, 467.75, 467.825  
**Mobile Observation Patrol 100**, Rockaway, NY: 469.5375  
**Moms Transport**, Peekskill, NY: 151.745  
**Mothers Against Drunk Driving (MADD)**, AL: 464.95  
**Motorcycle Escort Service**, Indianapolis, IN: 154.54  
**Nat'l. Safety Assn.**, Memphis, TN: 469.50  
**On The Road Again**, Parsippany, NJ: 462.125  
**Passages To Adventure**, Layland, WV: 464.40, 464.85  
**Protected Escort Svc.**, Louisville, KY: 151.685  
**Reach Tennessee**, Columbia, TN: 463.35  
**Road Jammers**, Phoenix, AZ: 463.50, 853.4875  
**Roadside Rescue**, Chicago, IL: 463.425  
**Roving Knights REACT**, PA: 462.675  
**Runway Inn**, Miami, FL: 462.725  
**San Jac Crash Rescue Team**, LA/MN/OK/TX: 151.625  
**Speedo 55 Check**, Pasadena, CA: 461.10  
**Speedway, Inc.**, USA: 151.625  
**Texas State REACT**, San Angelo, TX: 462.60, 462.675  
**Traffic Central**, Oakland & Sacramento, CA: 461.50  
**Traffic Control Specialists**, USA: 151.955  
**Traffic Control West**, USA: 464.90  
**Traffic Warning**, USA: 151.625  
**Truck Stops of America**, Waverly, GA: 464.65  
**Vehicle Recovery**, Sarasota, FL: 853.4625  
**Wanderguard**, Lincoln, NE: 154.57, 154.60, 154.625  
**Wheels On Wheels**, Mundelein, IL: 855.5375

A vehicle might be pulled over or searched for all sorts of odd reasons ranging from improper lane usage, failure to use signals when changing lanes, following too closely, driving too slowly, crooked or dirty license plate, etc. A driver has a right to refuse the vehicle search, however this could cause the driver to be detained until a search warrant is obtained. Refusal does arouse suspicions.

Of course, there are many profiles. Anybody who looks like they are returning from a Grateful Dead concert might be asked for a roadside interview. Even people who look "too normal" may look so out of place that they attract the attention of police. Large gold and diamond rings worn on many fingers, plus numerous gold wrist and neck chains is certain to fit someone's profile.

Peeling bills off a large roll to pay for gas

on the Interstate is going to have the police on your case as soon as the attendant can get to a phone to call up his cousin, the sheriff. Nervously gawking at a nearby patrol car driving past your red sports car with out-of-state plates is sure to earn you an invitation to pull over.

### The Bear Facts

If you have the right frequencies, you can listen in to the strategy of the officers as they try to pick the rotten apples out of the barrel. Listen in on all state and county law enforcement agency frequencies used in your area. Don't forget that some agencies use aircraft to spot cars, and radio the information down on frequencies like 122.9, 122.975, 123.3, or 123.5 MHz.

In my own area of Illinois, state troopers speak candidly to one another by switch-

# NOW YOU'RE TALKING!

## The Code-Free Ham License is Here

Enjoy all Amateur Radio privileges above 30 MHz without having to pass a code test. All you have to do is pass a 55-question exam on basic radio and the FCC regulations. ARRL's new book, **Now You're Talking** makes understanding what is required on the test a snap! And there are exams given all over the country every weekend.



Just think how much fun you'll have communicating through repeaters, enjoy Sporadic E skip and worldwide communications on six meters when conditions are right. There's satellite communication and you can even talk to Astronauts and Cosmonauts in orbit. Enjoy friendly local communication both direct and through repeaters. Help with disaster drills and the real thing! Sound like fun? It is! Order your copy of **Now You're Talking** below: Enclosed is \$19 plus \$4 for shipping (a total of \$23) or charge \$23 to my  VISA  Mastercard  Discover  American Express

**For More Information Call  
1-800-326-3942**

Signature \_\_\_\_\_  
 Acct. No. \_\_\_\_\_  
 Good from \_\_\_\_\_ Expires \_\_\_\_\_  
 Name \_\_\_\_\_  
 Address \_\_\_\_\_  
 \_\_\_\_\_  
 City \_\_\_\_\_ State \_\_\_\_\_ Zip \_\_\_\_\_ PC

**THE AMERICAN RADIO RELAY LEAGUE  
225 MAIN STREET  
NEWINGTON, CT 06111**

CIRCLE 2 ON READER SERVICE CARD

# MFJ SHORTWAVE ACCESSORIES REMOTE ACTIVE ANTENNA

**MFJ-1024** Receive strong clear signals from all over-the-world with this 54 inch active antenna that rivals long wires hundreds of feet long.

"World Radio TV Handbook" rates the MFJ-1024 as "a first rate easy-to-operate active antenna ... Quiet with excellent dynamic range and good gain ... Very low noise factor ... Broad frequency coverage ... the MFJ-1024 is an excellent choice in an active antenna."

Remote unit mounts outdoors away from electrical noise for maximum signal and minimum noise pickup. Mount it anywhere - atop houses, apartments, ships, buildings, balconies.

Covers 50 KHz to 30 MHz. High dynamic range eliminates intermodulation. Control unit has 20 dB attenuator, gain control. Lets you switch

2 receivers and auxiliary or active antenna. 'On' LED. 6x2x5 inches. Remote has 50 ft. coax and connector. 3x2x4 in. 12 VDC or 110 VAC with MFJ-1312, \$12.95



Truck weigh stations are effective check points for drug traffic. This one in Illinois operates on several frequencies.

## INDOOR ACTIVE ANTENNA

**MFJ-1020A** Now you'll rival or exceed the reception of outside long wires with this tuned indoor active antenna. "World Radio TV Handbook" says MFJ-1020 is a "fine value ... fair price ... best offering to date ... performs very well indeed."

Its unique tuned circuitry minimizes intermod, improves selectivity, reduces noise outside tuned band. Functions as a preselector with external antenna. 0.3-30 MHz. Telescoping antenna. Controls are Tune, Band, Gain, On-Off/Bypass.

6x2x6 in. Use 9 Volt battery 9-18 VDC or 110 VAC with MFJ-1312, \$12.95



ing away from their own frequencies and using simplex on 155.535 MHz. This is the output frequency of the county sheriff's repeater! Sheriff's deputies here (Williamson County, Illinois) sometimes talk privately by switching off their PL tones and operating simplex on 156.09 MHz, which is their repeater's input frequency. Without the PL tones, they don't kick the repeater on the air.

You can forget about finding where the best action is by simply looking it up cold in a beginner's low-cost frequency guide. These directories are OK, but best suited to Uncle Rudy, who is hoping to log every dog catcher and building inspector in the state. And Auntie Martha. The high point of her entire week is when she monitors a new station checking into the Sunday afternoon rescue team roll call.

noon rescue team roll call.

When it comes to monitoring exotic police comms on the truly hot channels used on the Interstates, the agencies like to do creative things with frequency usage. You are going to need better data, plus putting your imagination, experience, and monitoring skills to the challenge.

In addition to the law enforcement frequencies, Interstates offer all sorts of other frequencies of interest to the avid scannist. Don't forget CB Channels 9 and 19 (27.065 and 27.185 MHz, AM mode), or 462.675 MHz, which is used by many REACT groups for their operational comms. A listing of selected frequencies licensed for comms users that might turn up on the Interstates is provided here for informational purposes.

## ANTENNA TUNER/PREAMP



**MFJ-959B** Don't miss rare DX because of signal power loss between your antenna and receiver.

The MFJ-959B provides proper impedance matching so you transfer maximum signal from your antenna to your receiver from 1.6 to 30 MHz. You'll be surprised by significant increases in signal strength.

20 dB preamp with gain control boosts weak stations. 20 dB attenuator prevents overload. Select from 2 antennas, 2 receivers. 9x2x6 inches. Use 9-18 VDC or 110 VAC with optional AC adapter, MFJ-1312, \$12.95

For your nearest dealer or to order:

**800-647-1800**

Order from MFJ and try it. If not satisfied return within 30 days for refund (less s/h). Add \$5.00 s/h. One year unconditional guarantee. Free catalog.

**MFJ ENTERPRISES, INC.**

Box 494, Miss. State, MS 39762  
601-323-5869 Telex: 53-4590 MFJSTKV

MFJ... making quality affordable



This "plain wrapper" (unmarked police car) is parked in front of a law-enforcement agency. Note the antenna on the trunk-lid. The vehicle is used for patrol work on the nearby Interstate.



# STEP UP YOUR SHORTWAVE SET UP.

## **ISOLOOP 10-30 HF PORTABLE ANTENNA.**

This is the one that gives you freedom of speech, whether you have to deal with restrictive covenants at home or in your apartment or condo, or if you are traveling in your boat, car, or RV. It features 150 watts, continuous coverage from 10 to 30 MHz, narrow bandwidth to suppress out-of-band signals. The IsoLoop antenna comes fully assembled with no mechanical joints. There is simply no better value in antennas!

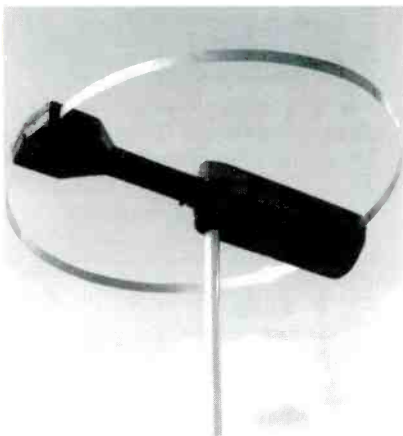

## **PK-232MBX DIGITAL MULTI-MODE CONTROLLER.**

It can receive eight different types of data signals, including Morse code, Baudot, ASCII, Time Division Multiplex (TDM), WEFAX, NAVTEX, Packet and AMTOR. Also featured is SIAM which automatically identifies many types of digital signals, excellent software support for PC compatibles, Macintosh and Commodore 64 & 128 computers. This unit is essential for the serious digital listener.



## **AEA-FAX.**

Here's the superior way to decode multi-level gray fax images received by your general coverage receiver. Featured is AEA's exclusive on-screen tuning scope that allows you to simultaneously tune and receive. There is also Autolist for unattended image capture and save-to-disk, "daisy-chain" external RS-232 input allowing AEA-FAX to share a COM port with PK-232 MBX, up to 16 gray levels (VGA), support for EGA, CGA and Hercules formats. AEA-FAX prints to HP LaserJet or Epson compatible printers and includes hardware demodulator, 3 1/2" and 5 1/4" software disks plus a comprehensive instruction manual. AEA-FAX is a must for your set-up!

*To connect with the AEA dealer nearest you or for product sheets, call (800) 432-8873.*



*Connect with us*

**Advanced Electronic Applications, Inc.**

PO Box C2160, 2006 - 196th St. SW, Lynnwood, WA 98036 Sales: (206) 774-5554

# The Secret Lives of Call Letters

**Many AM & FM Broadcast Stations Now Have Callsigns That Once Led Far Different Lives. Uncover Their Hidden Pasts & You'll Be Very Surprised!**

BY ALICE BRANNIGAN

**N**ot long ago we devoted coverage to call letters and their role in broadcasting. This brought in a considerable amount of comment from readers, including suggestions that we should have begun at the beginning, explaining the origins of call letters as they are presently used. Good idea!

Essentially, in the earliest days of wireless, there was no formal call sign system. In the era before 1908, stations used whatever callsigns or letters they found convenient, descriptive, or distinctive. For example, the Massie commercial station at Point Judith R.I. used *PJ*, and the DeForest station in New York City was simply *NY*. But problems arose as duplications started cropping up. The callsign *PJ* was also being used by the Belgian vessel *S.S. Princess Josephine*. The callsign *UA* was used by both the elegant Cunard passenger liner *RMS Umbria* and the United Fruit Company's scruffy banana freighter, *S.S. Ellis*.

As maritime wireless became increasingly popular, there were numerous confusing instances of the same identification being used by several coast and ship stations. This wasn't a viable system. Wireless was being installed on ships as a safety device to summon aid, so any station sending out a distress call would require its own completely unique identity signal.

The best approach was for all stations to have officially issued identity letters in order to avoid duplication and possible

confusion. The international radio convention in Berlin held in 1906 proposed such a system, which became effective in 1908. Canada was allocated the use of all call letters *VAA* through *VGZ*.

During the winter of 1909, the *RMS Republic* was rammed by the Italian passenger liner *SS Florida*. This was in heavy fog off of Nantucket, Mass. Jack Binns, the radio operator of the *Republic* began sending out distress calls on the ship's wireless. Although the *Republic* sustained severe damage, Binns' calls for help on the wireless summoned the steamer *Baltic* to the scene in time to save 1,650 passengers from both the *Republic* and the *Florida*. Although 6 lives and the *RMS Republic* were lost in the incident, Binns was hailed around the world as a hero. Wireless was given credit as being a life-saving miracle. It had been the first use of wireless at sea to save a large number of lives. Many ships began installing wireless.

Yet, our own government had not taken action in joining most other world nations in approving the Berlin convention. However the vital and dramatic role of wireless again in *RMS Titanic* disaster in April of 1912 brought this continuing and unexplained delay to the attention of the media and the public. The public demanded answers. Washington suddenly moved with deliberate haste. The Berlin convention was ratified by the USA in 1912. Also, that

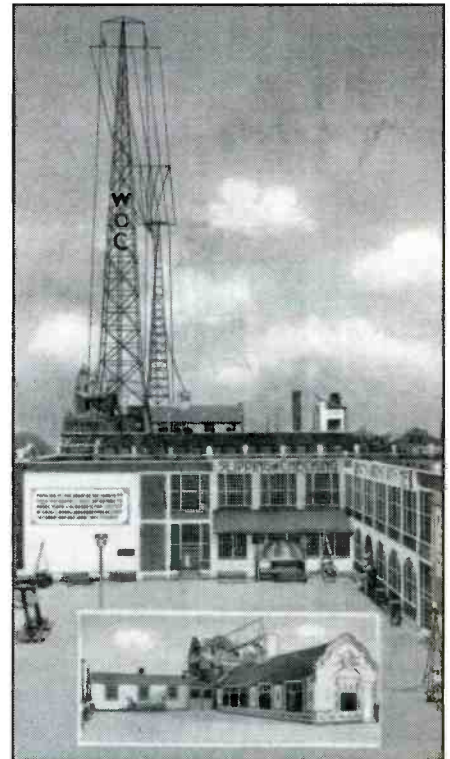

*WOC was the callsign of the Wilson Bros. steamer SS Oregon before it was reassigned for broadcast station use by Dr. Palmer's school of chiropractic in Davenport, Iowa.*

**VERIFICATION CARD FROM**

## KGW-PORTLAND, ORE.

483 Meters      1000 Watts      620 Kilocycles

It is a pleasure to be able to verify your report of reception from this station by means of this card.

The program you heard at 11:30 to 12:00 PM on October 14 was Dr. Poyntz Science Talk & Bagdad Organ

THANK YOU FOR THE COURTESY OF YOUR LETTER

## THE OREGONIAN STATION

Associated With the National Broadcasting Company

*KGW became a well-known broadcaster in Portland, Ore., after it went on the air in 1922. Before that, the call letters belonged to the SS Isabela.*

## KOA

NATIONAL BROADCASTING CO., INC.  
830 kilocycles (801.2 meters)  
DENVER, COLORADO

Dear Radio Friend:

We are glad to know of your interest in KOA's programs and thank you. Comments from interested listeners are most welcome and are appreciated.

We broadcast from 7:00 a. m. until 12:00 midnight mountain time each day of the week except Sunday, when we begin our schedule at 9:00 a. m. At any time we will be happy to give you available information concerning the time and content of any program in which you are especially interested.

Cordially yours, *Frances Jensen*  
For the Station.

Your reception of *Nov 17, 1931* is correct.

*KOA was originally the callsign of the SS Hamilton. In 1924 it was given a new lease on life after being reissued for broadcast station use in Denver, Colorado.*



# Scanners/Shortwave/CB/Radar

## COMMUNICATIONS ELECTRONICS INC.

### Emergency Operations Center

We're introducing new Uniden Bearcat scanners that are just what you've been searching for. Order your Bearcat scanner today.

## Radio Scanners

### NEW! Bearcat® 2500XLT-E

List price \$649.95/CE price \$344.95/SPECIAL

400 Channels • 20 Banks • Turbo Scan

Rotary tuner feature • Auto Store • Auto Sort

Size: 2-3/4" Wide x 1-1/2" Deep x 7-1/2" High

Frequency Coverage	Default Steps
25,000 - 25,995 MHz (AM)	5.0 KHz
26,000 - 28,995 MHz (AM)	5.0 KHz
29,000 - 53,995 MHz (NFM)	5.0 KHz
54,000 - 71,995 MHz (WFM)	50.0 KHz
72,000 - 75,995 MHz (NFM)	5.0 KHz
76,000 - 107,995 MHz (WFM)	50.0 KHz
108,000 - 136,995 MHz (AM)	12.5 KHz
137,000 - 173,995 MHz (NFM)	5.0 KHz
174,000 - 215,995 MHz (WFM)	50.0 KHz
216,000 - 224,995 MHz (NFM)	5.0 KHz
225,000 - 399,995 MHz (AM)	12.5 KHz
400,000 - 511,995 MHz (NFM)	12.5 KHz
512,000 - 549,995 MHz (WFM)	50.0 KHz
760,000 - 823,995 MHz (NFM)	12.5 KHz
849,0125 - 868,995 MHz (NFM)	12.5 KHz
894,0125 - 1,300,000 MHz (NFM)	12.5 KHz

Signal intelligence experts, public safety agencies and Popular Communications readers have asked us for a world class handheld scanner that can intercept just about any radio transmission. The new Bearcat 2500XLT is just what you've been waiting for. It can store frequencies such as police, fire, emergency, race cars, marine, military aircraft, weather, and other broadcasts into 20 banks of 20 channels each. The new rotary tuner feature enables rapid and easy selection of channels and frequencies. With the AUTO STORE feature, you can automatically program any channel. You can also scan all 400 channels at 100 channels-per-second speed because the Bearcat 2500XLT has TURBO SCAN built-in. To make this scanner even better, the BC2500XLT has AUTO SORT - an automatic frequency sorting feature for faster scanning within each bank. Order your scanner now.

For more information on Bearcat radio scanners or to join the Bearcat Radio Club, call Mr. Scanner at 1-800-423-1331. To order any Bearcat radio product from Communications Electronics Inc. call 1-800-USA-SCAN.

## Great Deals on Bearcat Scanners

NEW! Bearcat 890XLT-E base/mobile ...	\$254.95
NEW! Bearcat 2500XLT-E handheld .....	\$344.95
NEW! Bearcat BCT2-E info mobile .....	\$139.95
NEW! Bearcat 350A-E info mobile .....	\$119.95
NEW! Bearcat 700A-E info mobile .....	\$169.95
NEW! Bearcat 148XLT-E base .....	\$94.95
Bearcat 800XLT-E base/SUPER SPECIAL	\$199.95
Bearcat 760XLT-E base/mobile/SPECIAL	\$229.95
Bearcat 560XLA-E base/mobile .....	\$89.95
Bearcat 200XLT-E handheld/SPECIAL	\$208.95
Bearcat 100XLT-E handheld .....	\$149.95
Bearcat 70XLT-E handheld/SPECIAL	\$119.95
Bearcat 65XLT-E handheld/SPECIAL	\$99.95
Bearcat 855XLT-E base .....	\$159.95
Bearcat 210XLT-E base/SPECIAL	\$119.95
Bearcat 172XLT-E base .....	\$109.95
Bearcat 147XLT-E base .....	\$83.95

### NEW! Bearcat® 890XLT-E

List price \$489.95/CE price \$254.95/SPECIAL

200 Channels • VFO Control • 10 banks

Turbo Scan • Weather Alert • Priority channels

Auto Store • Auto Recording • Reception counter

Size: 5-1/4" Wide x 6-15/16" Deep x 1-5/8" High

Frequency Coverage	Steps
29,000 - 53,995 MHz (NFM)	5.0/12.5/25.0 KHz
108,000 - 136,995 MHz (AM)	5.0/12.5/25.0 KHz
137,000 - 173,995 MHz (NFM)	5.0/12.5/25.0 KHz
216,000 - 224,995 MHz (NFM)	12.5/25.0 KHz
225,000 - 399,995 MHz (AM)	12.5/25.0 KHz
400,000 - 511,995 MHz (NFM)	12.5/25.0 KHz
806,000 - 823,995 MHz (NFM)	12.5/25.0 KHz
849,0125 - 868,995 MHz (NFM)	12.5/25.0 KHz
894,0125 - 956,000 MHz (NFM)	12.5/25.0 KHz

The Bearcat 890XLT gives you pure scanning satisfaction with amazing features like Turbo Scan. This lightning-fast technology enables the Bearcat 890XLT to scan and search up to 100 channels per second. Because the frequency coverage is so large, a very fast scanning system is essential to keep up with the action. That's why Uniden's latest technology, Turbo Scan is built into our new Bearcat scanners. Other features include VFO Control - (Variable Frequency Oscillator) which allows you to adjust the large rotary tuner to select the desired frequency or channel. Weather Alert - Lets your scanner function as a severe weather warning radio. Auto Store - Automatically stores all active frequencies within the specified bank(s). Auto Recording - This feature lets you record channel activity from the scanner onto a tape recorder. You can even get an optional CTCSS Tone Board (Continuous Tone Control Squelch System) which allows the squelch to be broken during scanning only when a correct CTCSS tone is received. 10 banks - Each bank contains 20 channels, useful for storing similar frequencies in order to maintain faster scanning cycles. For maximum scanning enjoyment, order the following optional accessories: PS001 Cigarette lighter power cord for temporary operation from your vehicle's cigarette lighter \$14.95; PS002 DC power cord - enables permanent operation from your vehicle's fuse box \$14.95; MB001 Mobile mounting bracket \$14.95; BC002 CTCSS Tone Board \$54.95. Order your BC890XLT from CEI today.

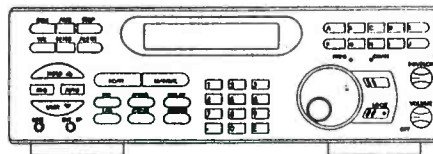

## CB/GMRS Radios

The new Uniden GMR100 is a handheld GMRS UHF 2-way radio transceiver that has these eight frequencies installed: 462.550, 462.725, 462.5875, 462.6125, 462.6375, 462.675, 462.6625 and 462.6875 MHz. This one wait radio comes with flexible rubber antenna, rechargeable ni-cad battery, AC adapter/charger, belt clip, F.C.C. license application and more. NEW! Uniden GMR100-E UHF GMRS Handheld. \$159.95  
 NEW! Uniden GRANTXL-E SSB CB Mobile ..... \$149.95  
 NEW! Uniden PC76XL-E CB Mobile ..... \$99.95  
 NEW! PRO320XLE CB Handheld/Mobile ..... \$69.95  
 Uniden PRO330E-E CB Remote ..... \$99.95  
 Uniden PRO810E-E SSB CB Base ..... \$158.95  
 Uniden PC122-E SSB CB Mobile ..... \$107.95  
 Uniden PC66A-E CB Mobile ..... \$78.95  
 Uniden PRO510XLE-E CB Mobile ..... \$36.95  
 Uniden PRO520XLE-E CB Mobile ..... \$49.95  
 Uniden PRO538W-E CB & Weather ..... \$69.95

## Shortwave

ICOM R1-E ultra compact handheld .....	\$439.95
ICOM R100-E mobile .....	\$589.95
ICOM R71A-E base (add \$29.00 shipping) .....	\$989.95
ICOM R72A-E base (add \$29.00 shipping) .....	\$899.95
ICOM R7000-E base (add \$39.00 shipping) .....	\$1,149.95
ICOM R7100-E base (add \$39.00 shipping) .....	\$1,199.95
ICOM R9000-E base (add \$89.00 shipping) .....	\$4,699.95
Grundig Satellit 700-E portable .....	\$459.95
Grundig Satellit 500-E portable .....	\$359.95
Grundig Cosmopolit-E with tape recorder .....	\$179.95
Grundig Yacht Boy 230-E portable .....	\$139.95
Grundig Traveller 2-E portable .....	\$79.95
Sangean AT5606-E ultra compact .....	\$149.95
Sangean AT5800-E portable .....	\$79.95
Sangean AT5803A-E portable .....	\$159.95
Sangean AT5808-E portable .....	\$159.95
Sangean AT5818CSE with tape recorder .....	\$209.95
Sangean ANT60-E portable shortwave antenna .....	\$14.95

## Weather Stations

Public safety agencies responding to hazardous materials incidents must have accurate, up-to-date weather information. The Davis Weather Monitor II is our top-of-the-line weather station which combines essential weather monitoring functions into one incredible package. Glance at the display, and see wind direction and wind speed on the compass rose. Check the barometric trend arrow to see if the pressure is rising or falling. Our package deal includes the part #7851-E Rain Collector, and the external temperature/humidity sensor, part #7858-E. The package deal is order #DAVI-E for \$449.95 plus \$15.00 shipping. If you have an IBM PC or equivalent, when you order the optional Weatherlink computer software part #7862-E for \$149.95, you'll have the world's most powerful computer weather station at an incredible price.

## Other neat stuff

ICOM GP22-E Global Positioning System .....	\$739.95
WR200-E Weather Radio with storm alert .....	\$39.95
RELM R1256NB-E VHF synthesized transceiver .....	\$289.95
Ranger RC12950-E 25 watt 10 meter ham radio .....	\$244.95
Ranger RC12970-E 100 watt 10 meter ham radio .....	\$369.95
Uniden LR9000W-E Laser/Radar Detector .....	\$159.95
PWB-E Passport to Worldband Radio by IBS .....	\$12.95
LN-E Latest Intelligence by James Tunnell .....	\$12.95
NP-E Uniden National Police Directory .....	\$12.95
FBE-E Uniden Eastern Frequency Directory .....	\$12.95
FBW-E Uniden Western Frequency Directory .....	\$12.95

## Buy with confidence

It's easy to order from CEI. Mail orders to: Communications Electronics Inc., Emergency Operations Center, P.O. Box 1045, Ann Arbor, Michigan 48106 U.S.A. Add \$15.00 per radio for U.P.S. ground shipping and handling in the continental U.S.A. unless otherwise stated. Add \$6.00 shipping for all accessories and publications. Add \$6.00 shipping per antenna. For Canada, Puerto Rico, Hawaii, Alaska, P.O. Box, or APO/FPO delivery, shipping charges are two times continental U.S. rates. Michigan residents add state sales tax. No COD's. 10% surcharge for net 10 billing to qualified accounts. All sales are subject to availability, acceptance and verification. Prices, terms and specifications are subject to change without notice. We welcome your Discover, Visa, American Express or MasterCard. Order toll-free by calling 1-800-USA-SCAN. For information or if outside the U.S.A. call 313-996-8888. FAX anytime, dial 313-663-8888. Order your electronic equipment from Communications Electronics Inc. today.

Scanner Distribution Center and CEI logos are trademarks of Communications Electronics Inc. Sale dates 5/2/93 - 8/30/93 AD #041393-PCS Copyright © 1993 Communications Electronics Inc.

For credit card orders call  
**1-800-USA-SCAN**

**Communications Electronics Inc.**  
**Emergency Operations Center**

P.O. Box 1045, Ann Arbor, Michigan 48106-1045 U.S.A.  
 For information call 313-996-8888 or FAX 313-663-8888

year the US Radio Act was passed, and American wireless stations started being issued and first began using official government-assigned call letters.

Ratification of the Berlin convention gave the USA exclusive international use of the distinctive call letters KDA to KZZ, NAA to NZZ, and WAA to WZZ. Our government elected to reserve the use of the N prefix for stations operated by the US Navy and Coast Guard. In addition, the call letters WUA through WVZ, and WXA through WZZ were set aside for use by the US Army.

During radio's infancy, practically all commercial land stations were on the coast and all communications were with ships. Most of the early US call letters assignments were for 3 letters. By 1914, these combinations had been exhausted making it necessary to also use 4-letter callsigns. The international radio conference in 1927 took away the call letter bloc KAA to KCZ from Germany and reallocated it to the USA to meet the nation's growing needs. Four-letter calls were assigned to ships and fixed stations in domestic point-to-point service. As of the mid-1920's, US ships holding 3-letter callsigns were all being

assigned new ones with the 4-letter format. Five-letter calls prefixed with KH were being issued to aircraft.

Experimental stations used the prefix letter W (or K, if outside the continental USA), followed by a number designating the radio district, the letter X, and then not more than 2 letters. Amateur station callsigns were similar, although the letter X was replaced by any letters *other than X*. Amateur stations in territories and possessions were each given a special distinctive 2-letter prefix beginning with the letter K.

After inland commercial radio developed, the Mississippi River was made the dividing line for the assignment of the K and W prefixes. Stations in the east used the W prefix, western stations used the K prefix. A number of early broadcast stations (such as WRR in Dallas, or KDKA in Pittsburgh) were assigned call letters before this policy went into effect.

With few exceptions, expired or otherwise discontinued call letters are and have been recycled and reissued. As of the past few years, ham radio calls have not been reissued. When oceangoing civilian ships are lost due to accident or act of war, when they are transferred to a foreign flag, sold

for scrap, or otherwise go out of US documentation, their call letters are reissued. In the USA, very often such discontinued maritime call letters are recycled for broadcast station use.

Beginning in 1921, ship call letters that had been assigned for the first time in 1912, were being almost instantly reissued to stations commencing operations in the newly created broadcast service, as well as in various commercial services. These call letters had still been actively in use by ships as late as 1920.

Early ships' wireless call letters that later went on to make history after being put into use by pioneer broadcast stations include (selected examples): KOY, KZN, KFOA, KMO, WSOE, KFAE, WDAE, WDZ, WSUI, WCAO, WDAU, WEW, WIL, WCAU, WCAE, WFAA, KDB, KEX, KFH, WMT, WOW, KGW, KFI, KGU, KOY, KMA, KOH, WGR, WJW, WKY, KXL, KLO, KGY, KXA, KXO, KIT, KGY, WSB, WWJ, WIP, WOC, KNX, KLZ, KMJ, KHJ, WWL, WLS, WOR, KWG, WBAA, WBZ, KQW, WSM, WGN, WGY, WHO, WRR, KYW, and KOA. Though some of the broadcasters eventually changed several of these calls in later years, virtually all of the

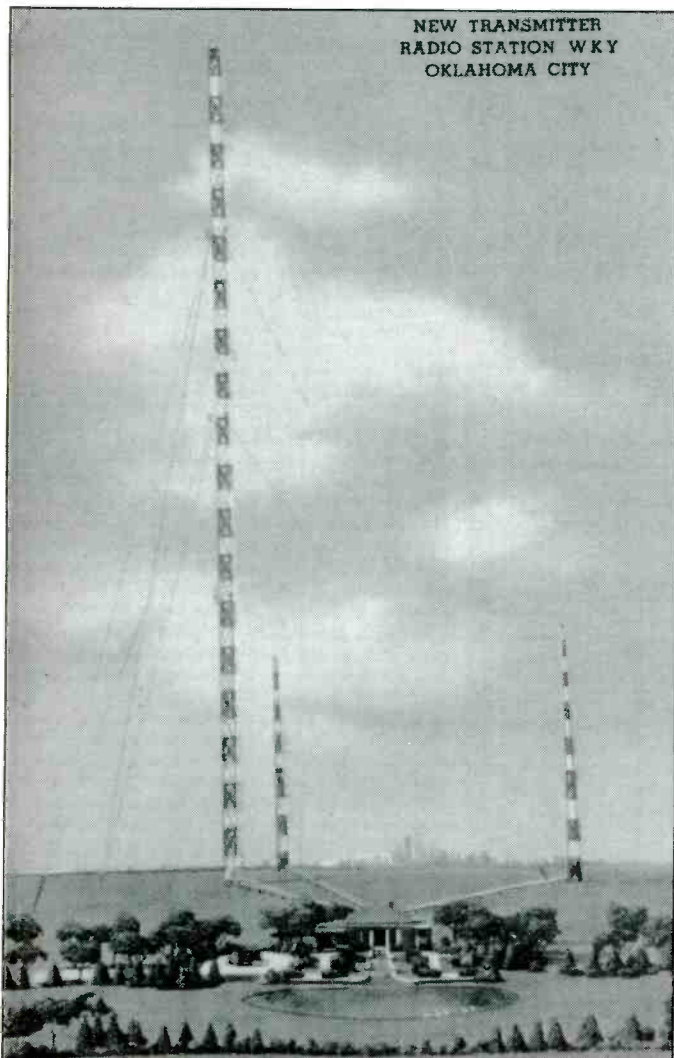

← The SS Montoso once held the call letters WKY. In 1921, the call was reissued to experimental broadcaster 5XT in Oklahoma City, Oklahoma, when the station upgraded to commercial broadcaster status. The WKY callsign is still used by this station.

The tanker Henry F. Sinclair was torpedoed by an enemy U-boat during WWII. The vessel's call letters, KGOK, are now assigned to an FM broadcast station in Oklahoma. ↓

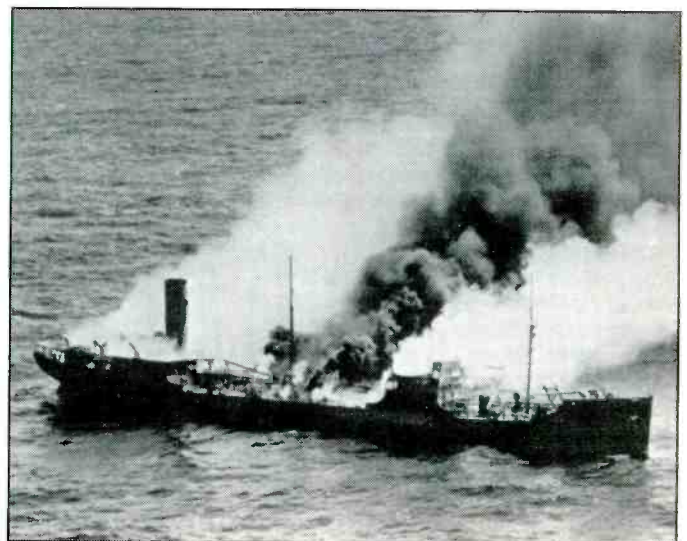



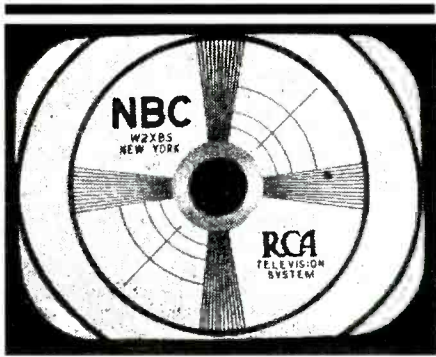

W2XBS (shown beneath the letters NBC in the upper left quadrant) was a typical old-style experimental call, similar to those assigned to ham operators. W2XBS was RCA's TV station in New York City during the 1930's.

stations listed here are still operating in one form or another! It's doubtful that these stately stations realize their first broadcast call letters were actually reincarnations from earlier existences as gristly old salts that spent years prowling the world's seas.

Trace the history of a given broadcast station's retread ship's wireless call letters and you're likely to uncover high adventure. Many of the recycled maritime call letters given to broadcasters had been inherited from ship stations that made headlines through tragedy. Some examples?

In 1923, the call letters KGB were assigned to an obscure and short-lived broadcaster in Tacoma, Wash. By 1927, the call letters were assigned again, this time to another broadcaster who made them famous. In 1927, KGB was put into use by the former KFBC, San Diego (now known as KPOP on AM, but still KGB on FM). But before all of this, KGB had originally been

issued to the steamship *D.H. Luckenbach*. This ship was torpedoed and sunk by a German U-boat off the coast of France in 1917.

In 1922, the call letters KOB were assigned to a new broadcaster in Albuquerque, N.M. (now known as KKOB on AM, but still KOB for TV). These call letters had been recycled. KOB had originally been the callsign of the Old Dominion Line's beau-

tiful passenger steamer *SS Princess Anne*. On February 6th, 1920, while traveling from Norfolk to New York, the 3,629 ton luxury vessel encountered a blizzard. Lost in the strong winds, blinding snow, and heavy seas, the ship ran hard aground on treacherous Rockaway Shoals, three miles south of Fort Tilden. This is west-southwest of New York Harbor.

The ship radioed for help. USCG cutters and police launches responded the following day when the storm began to subside. They removed 60 shivering and hungry passengers and crew members. Twenty crew members remained on the ship to help in efforts to refloat the vessel. Unfortunately, the hull had been damaged. Hold 3 was filled with water. The Coast Guard was unable to dislodge the *Princess Anne*. A few days later the abandoned ship broke in two and was pounded to pieces by the ocean. It was a total loss.

The call letters KOB had suddenly become ready for reassignment. On April 5, 1922 the callsign KOB was first put into use by Dr. Ralph Goddard, Albuquerque, N.M. This was because he was upgrading 5XD, his experimental broadcasting station (operating since 1920) to commercial status. Retired to shore duty after its harrowing nautical sea experience, the callsign KOB went on to become a well known fixture on the mediumwave band from Albuquerque for more than 60 years!

World War II sea losses and disasters made many additional ship call letters avail-



WHT was originally the callsign of the *SS Whittier*. In 1924, the call letters were issued to a coastal telegraph station in Rogers City, Mich. By 1925, the call WHT had been reissued again, this time for broadcast use by a Chicago station that (in 1930) evolved into WCHI, then went dark two years later.

## The Best\* Just Got Better!

The Eavesdroppers™ now includes our new Zap Trapper™ Electronic Gas Tube Lightning Arrestors. Receive-only design shunts damaging transients to ground at only 1/7th the voltage buildup of the available 200 watt transmit-type arrestors, providing maximum solid state receiver protection.

Protect your investment - combine an excellent shortwave receiving antenna with the best receiver protection money can buy.



- Completely assembled and ready to use
- Only 42' overall length
- 8 trap circuits permit reception on all shortwave bands, 11-90 meters.
- All connections soldered and enclosed in ultrasonically-welded, hermetically-sealed trap covers
- Includes 50' of 450 lb. test nylon rope

- **Model T** includes 100' twinlead feedline
- **Model C** includes weatherproofed center connector for your coax & coax sealant
- Either model \$79.95
- UPS for lower 48 states \$5.00
- COD add \$4.50, IL add 7% sales tax
- Foreign shipping quoted

\*"The best...built like an antenna should be."—Larry Magne in *World Radio TV Handbook*

\*"Our best seller."—EEB in their recent ads and catalogs

\*"Now in use in 45 countries."—Giffler Shortwave in 1983

## Antenna Supermarket

P.O. Box 563 Palatine, IL 60078 Tel (708) 359-7092 Fax (708) 359-8161

At your dealer or direct • Visa & Mastercard accepted

Save on **ALL** **REALISTIC** WITH MANUFACTURERS WARRANTY IN U.S. (copy available on req.)  
Scanners & Radios

**FREE**  
SHIPPING & HANDLING  
48 STATES

**PRO-43**  
~~\$350~~  
**\$298**  
INCL. BATTERIES  
(license fee, odd areas fee)

48,000 frequencies  
200 channels  
Hyperscan 25 ch/Sec.  
50 frq  
20 channel memory banks  
Back light LCD  
Memory backup circuit

CALL FREE: 1-800-433-SAVE  
(9-5 Central Mon.-Fri.)

**FORT WORTH COMPUTERS**  
EST. 1981

Fort Worth Computers  
377 Plaza, Granbury, TX 76048

**Let Your Computer Control Your Radio!**  
... with SCANCAT

Once you use the SCANCAT computer program with your radio, you will never operate your radio again without it! SCANCAT Version 4.5 controls the following radios:

- ★ AOR 2500, 3000
- ★ DRAKE R-8
- ★ ICOM R-71, R-7000, R-7100, R-9000
- ★ JRC NRD-525, NRD-535
- ★ KENWOOD R-5000, TS-440, TS-450, TS-711, TS-950
- ★ YAESU FT-757GX, FRG-9600

For other ICOM and Kenwood radios please call.

- UNIVERSAL FEATURES**
- ★ Create Frequency Databases
  - ★ Scan between ANY frequencies
  - ★ Up to 400 frequencies/file
  - ★ Scan by ANY increment & delay
  - ★ Built-in TNC comm program
  - ★ Share ANY radio's file



**AOR-3000, ICOM, NRD-535  
FRG-9600 FEATURES**

- ★ Auto signal detection/scan stop
- ★ Auto logging to diskfiles
- ★ Spectrum analysis with spectacular graphics
- ★ Save/load radio's memories to disk

Version 4.5 also includes SCANPORT. SCANPORT allows you to download your favorite BBS or import most columnar frequency lists to a running SCANCAT file.

CALL or write for FREE information or for our \$5.00 fully operational demo disk. We are so convinced you will buy SCANCAT, we'll even refund the cost of the demo and postage when you purchase SCANCAT!

Requires MS-DOS compatible computer w/RS-232C serial port. Manufacturer's Interface not included.

Optional squelch detect cable - \$24.95 + \$5.00 P & H

**\$49.95** (Foreign add'l \$2.00)  
Charge Cards and COD Welcome • Please Call!

**J & J Enterprises**  
P.O. Box 18292, Shreveport, LA 71138  
4001 Parkway Drive, Bossier City, LA 71112  
Phone (318) 683-2518 (8-5 CST M-F)  
FAX (318) 686-0449 (24 Hrs)

**HOKA CODE 3 is now available starting at \$495**  
Call or write for more information

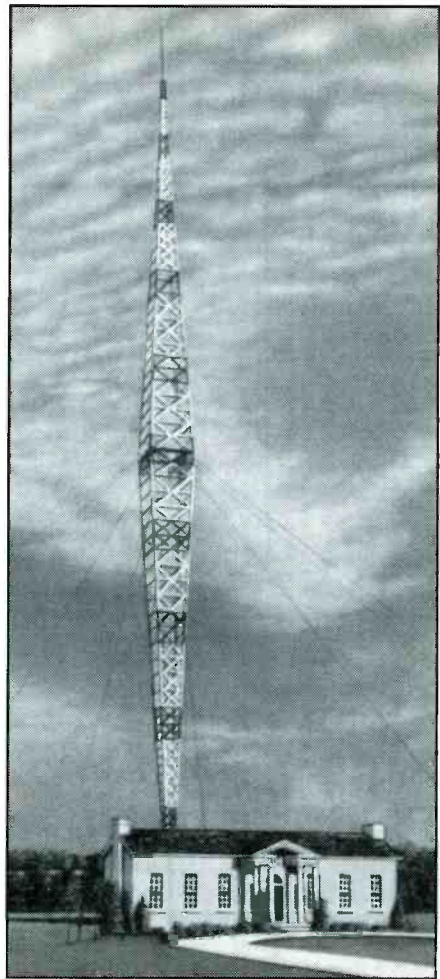

*WSM was once the callsign of the SS Fair Oaks. But it didn't become nationally famous until after it was reissued in 1925 for use by the National Life and Accident Insurance Company's new broadcasting station in Nashville, Tenn.*

able to lead calm new lives after being retired to the broadcast service. A few typical examples:

WSCY was the call issued to the 5,992 ton Socony-Vacuum Oil Co. tanker, *Tiger*. In April of 1942, the *Tiger* was torpedoed and sunk by the Nazi U-boat U-754 near Cape Henry, Va. One crew member died, 41 other persons on board were saved. In 1961 the call letters WSCY were reissued to an FM broadcaster on 100.9 MHz in North Syracuse, N.Y. (present call letters WKZX).

KDWN was the call of the 7,953 ton Tidewater Oil Co. tanker *Byron D. Benson*. In April of 1942, while transporting 100,000 bbl. of crude oil, she was torpedoed by the Nazi U-boat U-552. In the ensuing fire, 10 members of her 37-member crew were lost. In 1975, the call letters KDWN were assigned again—this time to the broadcast station in Las Vegas, Nevada on 720 kHz.

The call letters KGOK had belonged to the 6,151 ton tanker *Harry F. Sinclair, Jr.* In April, 1942, while carrying 68,000 bbl.

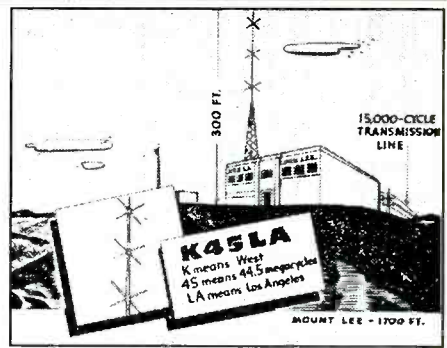

*This 1941 QSL from Los Angeles FM broadcast station K45LA explains its startling new call letters. It says that K means west; 45 means 44.50 MHz; LA means Los Angeles. In a bureaucratic sort of way, this does make sense.*

of fuel oil and gasoline, the vessel was torpedoed off the coast of North Carolina by the Nazi U-boat U-203. Ten of the crew died. In 1978 the call letters were reissued to an FM broadcaster on 97.7 MHz in Pauls Valley, Okla.

WQCC was the call of the 7,117 ton freighter *Santore*. In June, 1942, the *Santore* struck a submerged mine near Chesapeake Bay. That caused the vessel to sink, taking 3 members of the crew down with her. These call letters were reissued in the early 1980's to the station on 1540 kHz in Charlotte, N.C. that first went on the air on 1964 as WRPL, and which is presently known as WOGR.

What with 3-letter and 4-letter US callsigns having been used by maritime, broadcast, police, fire, and other services since the 1912-1914 era, these calls have racked up exciting stories about themselves, mostly forgotten. All it takes is a bit of digging through their genealogies to pry loose their deepest secrets.

Callsign formats have changed in many ways over the decades. Experimental call letters now use a two letter prefix, beginning with K, followed by 2X, then 2 letters. And, does anybody remember the evolution of FM broadcast station call letters?

The first FM broadcasters had standard Experimental station call letters, but that changed. In 1941, their callsigns moved into a new format where listeners were greeted with callsigns like W47C, W69PH, and K45LA. These were later modified to a traditional call letter format.

Hope this answers most or all of the questions raised in the aftermath of the previous coverage of call letters. Or have we now opened up other cans of peas? Either way, please let us know!

**We Will Return**

Join us again! Thank you for your help, questions, comments, suggestions, and contributions of old radio QSL's, picture postcards, stories, station rosters. Your support is very much appreciated. ■





**Get instant tech information FREE from your Fax or Computer!**

You can obtain specs, freq. info, software and more from our automated services. For fax facts, call from your stand alone fax machine and follow the voice prompts. Use the BBS from your modem of fax/modem equipped computer. Dial 317-849-8683 for fax back service, or dial 317-579-2045 for our computer bulletin board service

**Turn your AOR receiver into a full function Spectrum Analyzer!**



- AOR SpectraVu SV150**
- 0 to 1300MHz\***
- 80dB on Screen Range**
- >500MHz Span\***
- 0-50dB Attenuator\***
- Marker Generator**
- Selectable Bandwidth**
- 117dBm Sensitivity**

Connect two wires to the rear of your receiver, two wires to the vertical and trigger inputs of any oscilloscope, plug in the supplied power adaptor and you've got it! A full function Spectrum Analyzer. You'll get an instant update, real time display of any off air or inputted frequency spectrum. You can see over 500MHz of spectrum



at one time! The SpectraVu is not just an I.F. monitor that only displays a maximum of 10MHz at a time and is slaved to a receiver. Instead, the SpectraVu actually takes over the phase locked loop tuning of your AR2500 or AR2800. Switch the SV150 from receive to either the high or low spectrum mode. You can watch more than 500MHz of bandwidth, or zoom in by narrowing the view down to zero. The built in marker generator

makes frequency identification quick and easy. Then flip back to receive mode and listen to what you've found. The SV150 is fast enough to find new transmitters, or interference sources, yet accurate enough to be used for tuning L/O's, filters, or checking cable or antennas or on any kind of RF system. We'll do the installation hook-up of your SV150 to your AR2800, AR2515, AR2002 or AR2500 absolutely free of charge during our introductory period; at the time of initial purchase or on your present unit when returned prepaid.

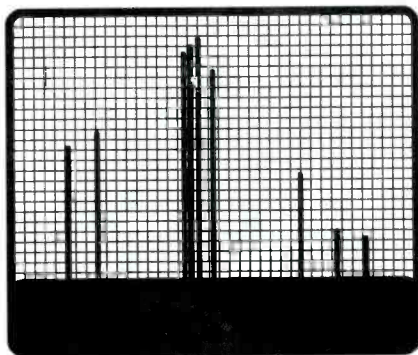

\*Here's the small print you've been looking for! The max span and hi/lo band split depend on the 1st I.F. of the unit. Sensitivity is dependent on radio unit. Requires mods to PLL of receiver. 50 dB attenuator is an extra cost option. Interface to the AR1000 or the AR3000, is not yet available. Cabling required: One extra DB9 connector and one extra BNC connector on back of receiver. Two cables to oscilloscope. One



12VDC adaptor, supplied. Size: 4 1/2"W x 1 1/4"H x 5 1/4"D. Wt: 12oz. Fax Facts #910 One year warranty. Introductory period ends 6/30/93. Call for info on oscilloscopes & accs. AOR SpectraVu SV150. \$179.95

**AOR GW-2 GaAs FET Wide Band RF Pre-Amp**

The GW-2 Wide Band Pre-Amp is designed to increase the signal levels present at the input to receivers, frequency counters, spectrum analyzers, etc. There are three basic advantages to the GW-2 design. 1. Wide range, low noise. Use of a GaAs Field Effect Transistor instead of the silicon FET's normally used in comparable devices for far less noise. 2. Variable Gain. Unlike many other signal amplifiers, the GW-2 allows you to vary the amount of gain it produces. 3. Portability. The GW-2 is completely powered by an internal 9 Volt DC standard transistor battery. The chart below shows typical maximum gain figures achieved by GW-2 over complete operating range.

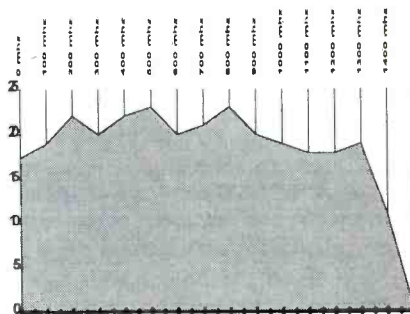

Specifications: Input/Output Impedance: 50 W. Gain: 20 dB nominal (-3 to + 20 adjustable). Input level: -5dbm max. Output level (1dB compression) +4 dbm. Noise figure (typical): 1.5db. Size: 3 1/4D x 4 3/4H x 7/8D. Wt 5 oz. Fax Facts #805 \$89.00 Also, if you have too many of the wrong kind of signals use our: **AOR MPIF-1 Interference Filter** Designed to reduce image and intermod in three areas: FM broadcast/TV, paging, and cellular. Small, convenient case with BNC connectors. Paging intermod filter is switchable. Fax facts # 905. Same size & wt. as GW2 above. \$59.00

**Toll Free, 24 Hours! 800-445-7717 Fax Orders 800-448-1084 Fax Facts 317-849-8683**

Computer BBS Modem & Fax/Modem, **317-579-2045**. Toll Free Tech Support, Dial **800-874-3468**

International Fax: en Espanol, en Francais, und auf Deutsch, or just fax in plain English to: **317-849-8794**



**ACE Communications 10707 East 106th Street, Fishers, IN 46038**

Service & Support hours: Mon.-Fri. 9AM to 6PM, Sat. 10-4 EST. Mastercard, Visa, Checks, Approved P.O.'s & COD (add \$5.50) & AMEX. Prices, specifications and availability subject to change. Flat rate ground shipping and handling charge only \$5.95 per unit. Express Air only \$8.95, for most units, to most locations. One week trial, no returns accepted two weeks after original receipt without substantial restocking charge. All units carry full factory warranty. Indiana residents add 5 per cent sales tax.



**FLY IT! ONLY \$8.95**

# BOOKS YOU'LL LIKE

BY R.L. SLATTERY

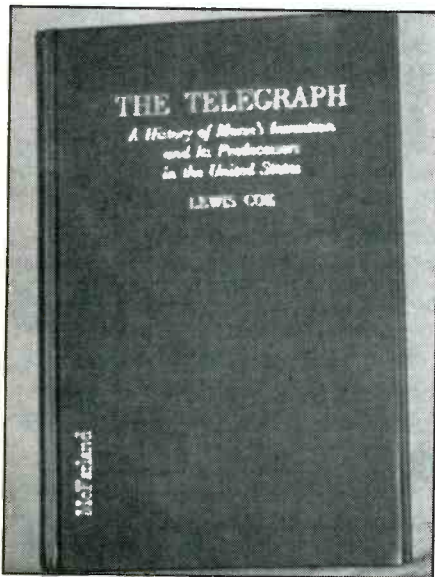

## About The Telegraph

Lewis Coe's new book, *The Telegraph: A History of Morse's Invention & Its Predecessors in the United States* is a 184-page exploration of a revolutionary communications development.

Samuel Morse's invention marked a new era in the ability to send messages because it permitted them to traverse great distances in both directions very quickly. Prior to that, important messages and business messages had required days or weeks to reach their destination after being dispatched by courier. Then, an equal amount of time was required for a reply to be received. The telegraph therefore had an amazing impact on people's lives, as well as on business and industry.

In this book, which contains 40 historic photos, Morse's invention is covered in great detail. The book's coverage begins in 1832, and it covers the establishment of the first intercontinental telegraph line in the USA, also the military implications of the invention on the Civil War. Coe discusses how the telegraph interacted with the railroads, and then how the advent of the wireless affected the telegraph.

Morse's telegraph was such a useful invention that it served the world in essentially its original form for more than 100 years. Recent advances in telegraph technology and its continued influence on communication are also examined in Coe's book.

Lewis Coe, who now lives in Indiana, is a former Morse telegrapher. He has written many previous pieces on the history of the telegraph and radio. Coe has done justice to Morse and his telegraph here with this well-researched and fine book.

*The Telegraph*, by Lewis Coe, is avail-

able from McFarland & Company, Inc., Box 611, Jefferson, NC 28640. The book is \$25.95, plus \$2 postage.

## Shiver Me Timbers

The movie *Pump Up The Volume* was as inaccurate a view of pirate broadcasting as there is, but it fit the public's image of the young, unlicensed, rebel broadcaster. Whatever. It directed a considerable amount of interest towards pirates. Made many people want to tune them in. Possibly the film inspired several people to try pirate broadcasting, despite the many penalties to befall any who get caught operating a pirate broadcast station.

There has been no shortage of pirate radio activity on the air, despite much FCC rattling of sabers, and an occasional citizen alleged by the FCC to be a pirate. Some of the pirates are so dreadful that you hope it won't be much longer before they're made to walk the plank. Others are so good that they rival many commercial stations.

*The 1993 Worldwide Pirate Radio Logbook*, by Andrew Yoder, is a 92 page directory of the shortwave pirates that are currently logged in North America, Europe, and Oceania. Information provided includes frequency and sked data (as observed). Stations are sorted by frequency and by identification. Pirate station address information is provided, so far as it is known.

Yoder has also offered an overview of what's taking place within pirate broadcasting around the world, along with his thoughts on trends he sees for the future. There are thousands of listings in this book. It's a useful reference for all who pursue this aspect of DX'ing.

*The 1993 Worldwide Pirate Radio*

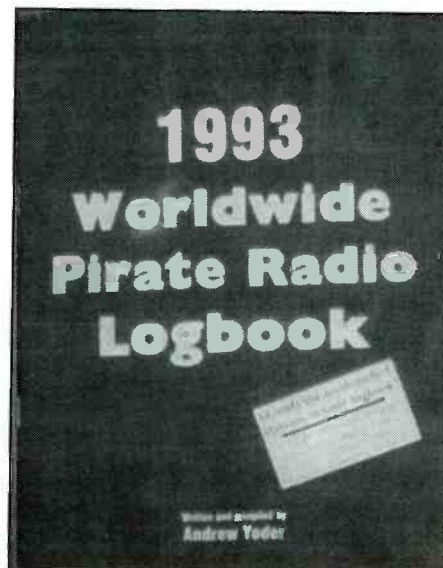

*Logbook* is \$10, plus \$2 postage and tax, from Snallygaster Press, Box 272, Springs, PA 15562.

## HamSats

*The HamSat Handbook*, by Tony Curtis, K3RXX, is a 152 page comb-bound book that provides the information needed to monitor or use ham radio satellites. It contains the uplink/downlink frequencies, modes, specs, and orbit data for each

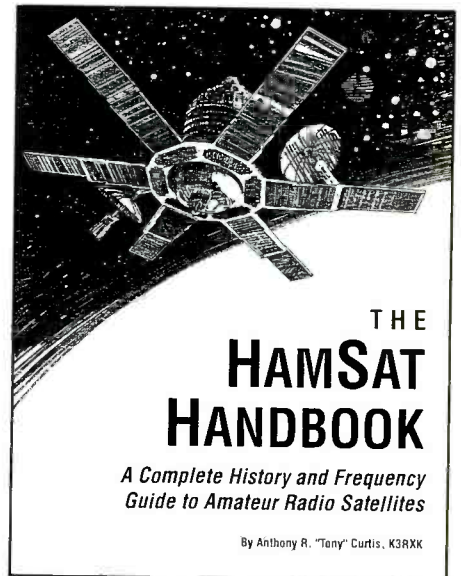

of the satellites launched by the various nations of the world.

Curtis covers the history of ham satellites, discussing the fate of every one ever launched. More than that, he has information on Oscars that will be coming up for launches encompassing the next several years.

Coverage is also given to hams in the Space Shuttle, as well as ham radio as it relates to orbiting space stations, moon-bounce, balloons, and meteor scatter.

When you look back at the first humble OSCAR satellite that operated for 3 weeks some 31 years ago, then see what lies ahead for 1997 and beyond, you can appreciate the strides that have been made. *The HamSat Handbook*, by Tony Curtis, is \$19.95, plus \$2 shipping/handling (\$3 foreign). Order from Tiare Publications, P.O. Box 493, Lake Geneva, WI 53147. VISA/MC accepted. Phone (414) 248-4845.

## Cellular Telephone Information Update

The new *Cellular Travel Guide, 4th Edition* is out. Formerly called *The Cellular Telephone Directory*, this is a



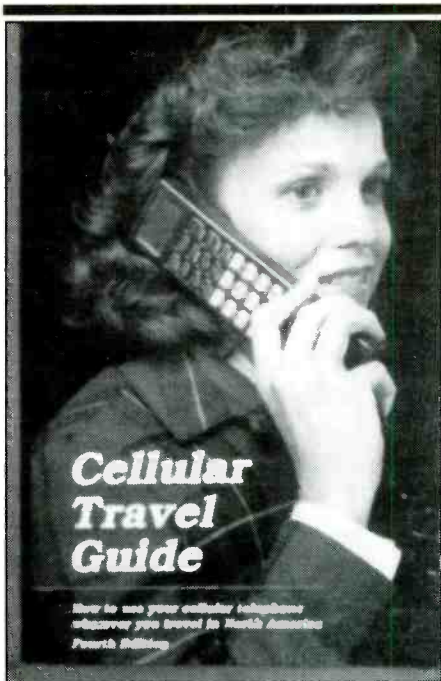

complete guide to all cellular service companies. If you are a cellular user, it will show you how to receive calls from home in every city you visit. How to place roamer calls. How to obtain service. Know which company charges the lowest visitor rates. Maps show the extent of each company's signal coverage area.

This giant new 1,184 page 4th Edition weighs more than 2 lbs. It includes many new cities and features. There are more than 500 maps, some 1,800 indexed cities, and 59 pages of listings of cellular systems in more than 115 nations. There are 66 pages of information showing roaming agreements, and a 28 page user's guide.

As you may know, wireline cellular service companies operate on exactly all of the same frequencies. Non-wireline cellular service companies also operate on their own group of the same frequencies. But that's where the similarity ends. Rates, available services, signal coverage, billing practices, and how they deal with roamers, varies widely between companies. Here's the one complete reference book that sorts out these variables and gives you a clear picture of where you stand.

Naturally, the names, addresses, and telephone numbers of all service suppliers are provided, along with all other relevant information.

No matter what your interest is in the 869 to 894 MHz wireline/non-wireline cellular bands, here's a lot of very useful information.

*The Cellular Travel Guide, 4th Edition*, is \$19.85, plus \$4.00 shipping/handling (\$5.00 to Canada). NY State residents add \$2.03 tax. Order from CRB Research Books, Inc., P.O. Box 56, Commack, NY 11725. VISA/MC welcomed. Order Line 1-(516) 543-9169; 24-hour FAX: 1-(516) 543-7486. ■

## SURVEILLANCE EQUIPMENT

THE BEST PRICES ANYWHERE  
Countermeasure Gear

New Miniature Transmitters with Surface Mount Technology, Phone Recorders, Touch Tone Decoders, Phone Tap and Bug Detectors, Cigarette Lighter Cameras and Much More!

For Catalog Send \$3.00 /  
Refundable with first order.

Counter Intelligence Applications, Inc.  
P.O. Box 1032, McLean, VA 22101  
(703) 893-7741

## CABLE TV CONVERTERS

Save \$100'S

- All makes and models
- Quality Equipment
- Shipped within 24 hrs
- Years of customers complete satisfaction
- Free catalog

L & L ELECTRONICS, INC.

1430 Miner St. Suite 522  
Des Plaines, IL 60016

VISA 1-800-542-9425 MASTER CARD

Purchaser Must agree to comply with all State and Federal laws.



## World's Most Powerful CB and Amateur Mobile Antenna\*

Lockheed Corp. Test Shows  
**Wilson 1000** CB Antenna Has  
**58% More Gain Than The  
K40 Antenna (on channel 40).**

In tests conducted by Lockheed Corporation, one of the world's largest Aerospace Companies, at their Rye Canyon Laboratory and Antenna Test Range, the Wilson 1000 was found to have 58% more power gain than the K40 Electronics Company, K40 CB Antenna. This means that the Wilson 1000 gives you 58% more gain on both transmit and receive. Now you can instantly increase your operating range by using a Wilson 1000.

Guaranteed To Transmit and Receive  
Farther Than Any Other Mobile  
CB Antenna or Your Money Back\*\*  
*New Design*

The Wilson 1000 higher gain performance is a result of new design developments that bring you the most powerful CB base loaded antenna available.

### Why Wilson 1000 Performs Better

Many CB antennas lose more than 50% of the power put into them. The power is wasted as heat loss in the plastic inside the coil form and not radiated as radio waves.

We have designed a new coil form which suspends the coil in air and still retains the rigidity needed for support. This new design eliminates 95% of the dielectric losses. We feel that this new design is so unique that we have filed a patent application on it.

In addition, we use 10 Ga. silver plated wire to reduce resistive losses to a minimum.

In order to handle higher power for amateur use, we used the more efficient direct coupling method of matching, rather than the lossy capacitor coupling. With this method the Wilson 1000 will handle 3000 watts of power.

### The Best You Can Buy

So far you have read about why the Wilson 1000 performs better, but it is also one of the most rugged antennas you can buy. It is made from high impact thermoplastics with ultraviolet protection. The threaded body mount and coil threads are stainless steel; the whip is tapered 17-7 ph. stainless steel. All of these reasons are why it is the best CB antenna on the market today, and we guarantee to you that it will outperform any CB antenna (K40, Formula 1, you name it) or your money back!

\*Inductively base loaded antennas  
\*\*Call for details.

### Lockheed - California Company

A Division of Lockheed Corporation  
Burbank, California 91520

Aug. 21, 1987

Wilson Antenna Company Inc.  
3 Sunset Way, Unit A-10  
Green Valley Commerce Center  
Henderson, Nevada 89015

Subject: Comparative Gain Testing of Citizen's Band Antennas  
Ref: Rye Canyon Antenna Lab File #870529

We have completed relative gain measurements of your model 1000 antenna using the K-40 antenna as the reference. The test was conducted with the antennas mounted on a 16' ground plane with a separation of greater than 300' between the transmit and test antennas. The antennas were tuned by the standard VSWR method. The results of the test are tabulated below:

FREQUENCY (MHZ)	RELATIVE GAIN (dB)	RELATIVE POWER GAIN (%)
26.965	1.30	35
27.015	1.30	35
27.065	1.45	40
27.115	1.90	45
27.165	1.50	41
27.215	1.60	45
27.265	1.75	50
27.315	1.95	57
27.365	2.00	58
27.405	2.00	58

**58%  
MORE  
POWER GAIN  
THAN THE  
K40**

Individual test results may vary upon actual use.

**CALL TODAY**  
TOLL FREE: 1-800-541-6116  
FOR YOUR NEAREST DEALER  
**Wilson 1000**  
Available in Black or White

Roof Top Mount ..... **59<sup>95</sup>**  
Trunk Lip Mount ..... **69<sup>95</sup>**  
Magnetic Mount ..... **79<sup>95</sup>**  
Wilson 2000 Trucker ..... **59<sup>95</sup>**  
DEALERS Exclusive dealer areas still open

**Wilson**  
ANTENNA INC.  
1181 GRIER DR., STE. A  
LAS VEGAS, NV 89119

## Low Frequency Antennas: Part 1

The low frequency bands, i.e. frequencies less than 7 or 8 MHz, pose some special problems for antenna builders. The best performing simple antennas for those frequencies are, like other bands, the quarter wavelength vertical and the half wavelength dipole. But these antennas are too long for many listeners, and must be installed too far above the ground (in the case of the dipole). For example, a vertical for 5500 kHz is 45 feet high. While not unworkable, it is still a bother to build a 45 foot high antenna. A half wavelength dipole for the same frequency is 85 to 90 feet long, and should be installed 45 feet off the ground. Clearly, some alternatives are needed.

In this month's column, and September's, we will take a look at some alternatives that give reasonable performance for people with only a moderate amount of space for antennas. Of course, you can always use a 25-meter or 31-meter band dipole, or a 50-foot untuned random wire, but sometimes performance is enhanced when other types of antenna are placed in service.

### Shortened Vertical Antennas

The biggest problem for most low frequency DX'ers, as we have seen above, is the excessive size of antennas for those frequencies; it is not for nothing that those AM broadcast band (<1.6 MHz) towers are usually hundreds of feet tall. But there are ways to shorten an antenna—not for free for the TANSTAAFL (There Ain't No Such Thing As a Free Lunch) principle still applies—to a point where it becomes mechanically possible. Let me reiterate once again that these compensation antennas will not work as well as a properly installed full-sized antenna, but will serve to get you on the air on frequencies where it is otherwise utterly impossible. Several different compensation configurations are popular, and these are shown in Fig. 1.

The basic foundation for these antennas is a very short vertical antenna. The "standard" vertical antenna is quarter wavelength ( $\lambda/4$ ), i.e. 90 degrees electrical length, and is unbalanced with respect to ground.

Recall that a vertical antenna that is too short for its operating frequency (i.e. less than  $\lambda/4$ ) will exhibit capacitive reactance. In order to resonate that antenna it is necessary to cancel the capacitive reactance with an equivalent inductive reactance, such that  $|X_L| = |X_C|$ . By placing an inductance in series with the antenna radiator element, therefore, we can effectively "lengthen" it electrically. Of course, what

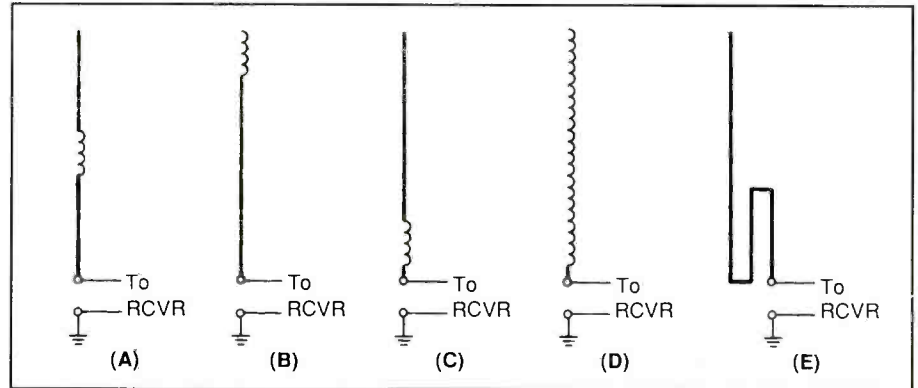

Figure 1

is really happening is that the effects of the lower operating frequency are being accommodated, i.e., "cancelled out," of a too-short antenna.

An antenna that is reactance compensated for a different frequency is said to be loaded, or in the case of a very low frequency antenna it is inductively loaded. Three basic forms of loading are popular: discrete loading, continuous loading, and linear loading.

Discrete loading means that there is a discrete, or lumped, inductance in series with the antenna radiator (Figs. 1A through 1C). These antennas are so constructed that a loading coil is placed at the center (Fig. 1A), top (Fig. 1B) or bottom (Fig. 1C) of the radiator element.

You will recognize these configurations as being the same as are found on mobile antennas. Indeed, low-band mobile antennas can be used in both mobile and fixed installations. Note, however, that it is convenient to use mobile antennas for fixed locations (because they are easily available in "store bought" form), but are less efficient than other versions of the same concept. The reason is that the mobile antenna for low frequencies tends to be based on the standard 96 to 102 inch whip antenna used by amateur operators on 10-meters or Citizen's Band operators on 11-meters. In fixed locations, on the other hand, longer radiator elements (which are more efficient) are more easily handled. For example, a 16 to 30 foot high aluminum radiator element can easily be constructed of readily available materials. The sixteen foot element can be bought in the form of one or two lengths of 1 to 1.5 inch aluminum tubing at Do-It-Yourself outlets.

A problem seen with these antennas is that they tend to be rather high-Q, so the bandwidth is necessarily narrow. An antenna may work in the center of a band, but present a high VSWR at the ends of the band, and thus, be unusable. This problem

is solved by making the inductor variable so that slightly different inductance values can be selected at different frequencies across the band. For the base loaded version at Fig. 1C this is particularly easy: a rotary inductor (perhaps motor driven for remote operation) can be used. For the other configurations, a tapped fixed inductor can be used instead. Each tap represents a different inductance value. Either clip connectors or relay connections can be used to select which tap is used.

A continuously loaded antenna has the inductance distributed along the entire length of the radiator (Fig. 1D). Typical of these antennas is the helically wound verticals in which about a half wavelength of insulated wire is wound over an insulating form (such as a length of PVC pipe or a wooden dowel); the turns of the coil are spread out over the entire length of the insulated support.

Linear loading (Fig. 1E) is an arrangement whereby a section of the antenna is folded back on itself in a manner similar to a stub. Antennas of this sort have been successfully built from the same type of aluminum tubing as regular verticals. For 75/80 meter (3.75 MHz) operation a length of 30 feet for the radiator represents 41 degrees, while a normal  $\lambda/4$  vertical is 90 degrees. The difference between 90 and 41 degrees of electrical length is made up by the "hairpin" structure at the base.

So how does the TANSTAAFL principle fit into all of this mess? It's simple, compensation antennas, of which class the shortened loaded verticals are an example, do not work as well as full sized  $\lambda/4$  or  $5\lambda/8$  antennas. They are also somewhat narrower in bandwidth, so performance will fall off more rapidly away from the design frequency. But they also represent one factor that cannot be denied: they work as well as can be expected in cramped quarters, and where the alternative is using your 25-meter dipole "in a pinch." ■



# COMMUNICATIONS CONFIDENTIAL

## YOUR GUIDE TO SHORTWAVE "UTILITY" STATIONS

**R**ichard Baker, OH reported that "DAN, Norddeich Radio, who has in the past refused to engage in the QSL business, is now sending out QSL cards. I received one, it came in 9 days! I sent a letter in English, and a SASE with mint stamps attached.

Here are three corrected addresses for USN ships. Published FPO's are wrong. USS Vreeland (FF-1068), FRP A.E. 09590-1428; USS Simon Lake (AS-33), FPO A.E. 09536-2590; USS Valley Forge (CG-50), FPO A.P. 96682-1170.

Several reference books show 11552 kHz for Antarctic comms but perhaps that is a typo. When I received my PFC back from the USCGC Polar Star (WAGB-10) they gave me a tip to listen for such comms on 11553 kHz. I did log Palmer Station on the frequency and hear 'chat' almost every night. But except for Palmer, comms have been too weak to ID.

Next is one of the strangest QSL letters, but it was very informative. It was in response to a QSL request I sent to Cape Radio, c/o NASA, KSC. It seems that a company called CSR operates the HF radios for the eastern test range, which is really Cape Radio's primary assignment. They will not complete a PFC, but once a month, at random, they draw a lucky winner from the pile of requests that came in, and answer (and verify) by letter."

For you computer buffs, Richard has advised that he now has a SWL Special Interest Group on the Youngstown Freenet. Richard indicated he can be reached via his E-Mail address of XX159@yfn.yzu.edu for further details.

Simon Mason, England said "OLX is still active and the OM/EE station went down to 4-5 MHz for the winter but in the summer it can be heard around 12 and 16 MHz. By the way, German number sta-

tions DCF37 and DFD21 ended in Dec of '92."

According to a Pacific Stars and Stripes article sent in by Ken Alyta, Korea, the LORAN station on Okinawa will change hands in July 1993 when the USCG turns the station over to the Japanese. The Japanese Maritime Agency personnel received training on the equipment in California at the Pataloma LORAN Transmitter School. Other LORAN stations, Iwo Jima, Hokkaido, and Marcus Island are also to be turned over to Japanese control in 1993.

Donald Tomkinso, CA wrote, "After seeing the NDB's that Vaage, CA submitted, I thought I would expand the Southern California loggings somewhat so I am sending in some of mine. Ten days of rain really cleaned off the hi-voltage insulators out here and lowered the noise level making for better reception of beacon signals.

Ken Sooy, Sr., NJ has been a SWL off and on since the '40's. "I have read POP'COMM since the first issue and just recently started to devote some time to the Ute's and I find it interesting. I used a Radio Shack DX-440 and a longwire antenna to get these loggings and I will continue to use this arrangement until I can spare some permanent space for a shack as I can presently set up and tear down in short order."

Henry Johnson, VA has added some information regarding the photo taken by R.C. Watts (see Feb. '93 column). "R.C. pointed out that the wires of the antenna on the British Admiralty building could not be seen in the picture. I thought readers might be interested in what I saw when I observed the same installation back in 1976 while I was on business in London. I recognized the antennas as the old style 'cage' antenna of some large diameter."

Cage antennas are still in use today and

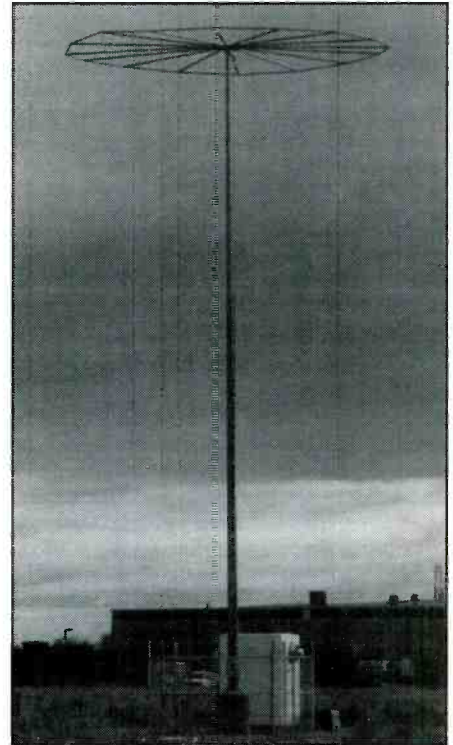

Patrick Griffith, CO provided this photo of Non-Directional Beacon TOT which is located about 10 miles north of Denver Stapleton AP. TOT operates on a frequency of 281 kHz.

some readers may recall the series of photos in the column from time to time that were provided by Professor Desmond Ball of Australia. The photos showed the antenna installations on the roofs of Soviet Embassies in various Capitals.

Ralph Craig, OH described an interference problem that was a mystery until it was tracked down. "I was an Engineer with the FAA trying to commission a landing

**ALGERIA** **الجزائر**

وزارة البريد والمواصلات السلكية واللاسلكية  
MINISTRE DES POSTES ET TELECOMMUNICATIONS

SWL : HIRGSHI SARTE ..... on : DE 17H 15 A 17H 31 UTC  
CFM My Transmission : NOVEMBRE 90  
ORG : .12.662..KHZ .....  
TX : .10..KW .....  
Mode CW-SSB-Fone : ..... Name : .....  
Ant : OMNIDIRECTION .....  
QTH : BOUFARIK .....  
Remarks : MERCI POUR LE RAPPORT  
Many fax fr ur nice report. 73 es best.

QSL received by Hiroshi Saito, Japan.

**COAST GUARD  
CORPUS CHRISTI, TEXAS  
GROUP (NOY8)**

QSL

DATE : 23MAR92 27-42 N  
FREQ : 2670 KHZ 97-16 W

Ed Rausch, NJ shares this Coast Guard QSL with readers.

**Abbreviations Used For Intercepts**

AM	Amplitude Modulation mode
BC	Broadcast
CW	Morse Code mode
EE	English
GG	German
ID	Identification/led/location
LSB	Lower Sideband mode
OM	Male operator
PP	Portuguese
SS	Spanish
tfc	Traffic
USB	Upper Sideband mode
w/	With
wx	Weather report/forecast
YL	Female operator
4F	4-figure coded groups (i.e. 5739)
5F	5-figure coded groups
5L	5-letter coded groups (i.e. IGRXJ)

aid. The flight check aircraft reported QRM on the frequency—108.9 MHz. When a receiver on the ground was tuned to the frequency a broadcast station could be clearly heard on the frequency whenever the transmitter for the aid was turned off. Using a vehicular mounted receiver we traced the signal to the broadcast station. The station engineer simply did not believe that his signal (1210 kHz) was being received at 108.9 MHz. Listening on our receiver and on another he was able to obtain, convinced him. We then went to the transmitter site to check and there it was discovered that there were two antennas on the tower. The steel tower of some 300



**NDVW**  
**USS**  
**NASHVILLE**  
**LPD 13**

---

**QSL**

**TRANSMITTER/POWER** 500 watts

**ANTENNA** 500 28' whip

**LOCATION** Norfolk Va

**VERIFYING OFFICIAL** W.D. Trigg

**FREQUENCY** 12315 mhz

**DATE** 9 DEC 1992

Joe Galante, NY used this PFC to obtain his reception verification.

feet high carried a FM antenna at the top, and running up the tower on 12 inch insulators was an AM antenna. The tower just being a support mechanism. When the engineer turned off either the AM transmitter on 1210 kHz or the FM transmitter on 107.7 MHz the QRM went away. Obvi-

ously, the FM and the AM signals were mixing and being reradiated on our frequency of 108.9 MHz. I do not know what the engineer did to correct the situation as the QRM ceased shortly after our visit. The stations were some 20 miles from the airport so the mixing product was fairly strong.

# RANGER SDM-1000

BASE MICROPHONE WITH  
UP/DOWN SCANNING

High-Fidelity Wide band frequency response give your station that broadcast studio sound!

- Electret element and high quality SMT-amplifier
- Modern slim line design – easy to use with minimum space requirement
- Designed for use with all amateur transceivers: HF-VHF-UHF-SHF
- Factory pre-wired for most popular transceivers
- Up-down buttons—locking type PTT switch
- Stable, heavy-duty, die-cast base
- Long-life watch type battery

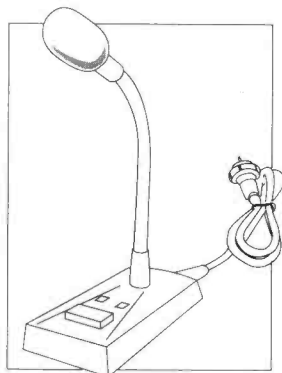

Pre-wired for:  
AR3300-AR3500-YAESU 8 pin transceivers  
Model F: AR3300-AR3500-YAESU 8 pin transceivers  
Model H: HR-2510/L/INCOLN  
Model I: RC1:2900/2950



**CLEAR CHANNEL  
CORPORATION**

PO Box 445  
Issaquah, WA 98027  
206-222-4295 FAX 206-222-4294

## PC HF FACSIMILE 6.0 \$99



## NOW EVEN BETTER!

Version 6.0 has just been released. It is the most comprehensive fax image reception system for the IBM PC and compatibles. It includes an FSK demodulator, advanced signal processing software, tutorial cassette, and complete 250 page reference manual. The software includes the following advanced features:

Menu Driven  
Start/Stop Tone Recognition  
Unattended Operation  
Tuning Oscilloscope  
Resolution up to 1280x800x256 Levels  
Programmable Colorization  
Brightness and Contrast Control  
Transmit Option Available  
Image Zoom, Scroll, Pan, Rotation

CGA,HGA,EGA,VGA & Super VGA  
Time Lapse Frame Looping  
Slide Shows  
Export to PCX & GIF Files  
Grayscale on all Popular Printers  
Programmable IOC & Line Rates  
Online Broadcast Database  
Image Cropping  
True Color Press Photos

## PC GOES/WEFAX \$250

PC GOES/WEFAX 3.0 is our finest fax imaging system. It is compatible with both HF and direct satellite broadcasts from GOES, METEOSAT NOAA, SOVIET APT and C-Band services. It includes all of the above features plus a complete prediction system and advanced multispectral analysis software. Call or write for our catalog of products. Visa & MasterCard welcome.

**Software Systems Consulting**  
615 S. El Camino Real, San Clemente, CA 92672  
Tel.(714) 498-5784 Fax.(714) 498-0568



# If you enjoy Amateur Radio, you'll enjoy CQ.



It's a different kind of ham magazine. Fun to read, interesting from cover to cover, written so you can understand it. That's CQ. Read and enjoyed by over 90,000 people each month in 116 countries around the world.

It's more than just a magazine. It's an institution.

CQ also sponsors these thirteen world famous awards programs and contests: The CQ World Wide DX Phone and CW Contests, the CQ WAZ Award, the CQ World Wide WPX Phone and CW Contests, the CQ World Wide VHF WPX Contest, the CQ USA-CA Award, the CQ WPX Award, the CQ World Wide 160 Meter Phone and CW Contests, the CQ Five Band WAZ Award, the CQ DX Award, and the highly acclaimed CQ DX Hall of Fame. Accept the challenge. Join the fun. Read CQ.

Also available in Spanish language edition. Write for rates and details.

## SUBSCRIBE TODAY!



The Radio Amateur's Journal  
76 North Broadway  
Hicksville, NY 11801

Please start my CQ subscription with the next available issue.

Enclose payment or charge information with order.  
Term and Rate (check one):

	USA	VE/XE	Foreign
1 Year	<input type="checkbox"/> 22.95	<input type="checkbox"/> 25.	<input type="checkbox"/> 27.
2 Years	<input type="checkbox"/> 43.	<input type="checkbox"/> 47.	<input type="checkbox"/> 51.
3 Years	<input type="checkbox"/> 63.	<input type="checkbox"/> 69.	<input type="checkbox"/> 75.

Paid by:  Check  Money Order  VISA  MasterCard  
 American Express



Card Number:

--	--	--	--

Allow 6-8 weeks for delivery of first issue

Name \_\_\_\_\_

Street \_\_\_\_\_

City \_\_\_\_\_

State or Country \_\_\_\_\_ Zip \_\_\_\_\_

UTC	FREQ	STATION	CALL	REMARKS
0010	2670.0	USCG, GROUP MORICHES, NY	NMY42	WX, NTM
0033	2670.0	USCG, GROUP ASTORIA, OR	NMW	WX, NTM
0103	2670.0	USCG, GROUP FORT MACON, GA	NMN37	WX, NTM
0133	2670.0	USCG, GROUP CAPE HATTERAS, NC	NMN13	WX, NTM
0203	2670.0	USCG, COMMSTA SAN FRANCISCO (CAMSPAC)	NMC	OFFSHORE WX,
0203	2670.0	USCG, GROUP HAMPTON ROADS, VA	NMN80	WX, NTM
0203	6501.0	USCG, COMMSTA KODIAK, AK	NOJ	OFFSHORE WX,
0233	2670.0	USCG, GROUP EASTERN SHORE, VA	NMN70	WX, NTM
0303	2670.0	USCG, GROUP HUMBOLT BAY, CA	NMC11	WX, NTM
0303	2670.0	USCG, GROUP MONTERREY, CA	NMC6	WX, NTM
0305	2670.0	USCG, GREATER ANTILLES SECTION, SAN JUAN	NMR1	WX, NTM
0320	2670.0	USCG, GROUP ST PETERSBURG, FL	NMA21	WX, NTM
0330	13089.0	USCG, COMMSTA GUAM	NRV	OFFSHORE WX,
0350	2670.0	USCG, GROUP MIAMI BEACH, FL	NCF	WX, NTM
0400	4426.0	USCG, COMMSTA PORTSMOUTH	NMN	OFFSHORE WX,
0400	6501.0	USCG, COMMSTA PORTSMOUTH	NMN	OFFSHORE WX,
0400	8764.0	USCG, COMMSTA PORTSMOUTH	NMN	OFFSHORE WX,
0420	2670.0	USCG, GROUP CHARLESTON, SC	NMB	WX, NTM
0430	4426.0	USCG, COMMSTA SAN FRANCISCO (CAMSPAC)	NMC	OFFSHORE WX,
0430	8764.0	USCG, COMMSTA SAN FRANCISCO (CAMSPAC)	NMC	OFFSHORE WX,
0430	13089.0	USCG, COMMSTA SAN FRANCISCO (CAMSPAC)	NMC	OFFSHORE WX,
0440	2670.0	USCG, COMMSTA BOSTON	NMF	MARINE INFOR
0530	2670.0	USCG, STATION CHANNEL ISLAND, CA	NMQ8	WX, NTM
0530	4426.0	USCG, COMMSTA PORTSMOUTH	NMN	OFFSHORE WX,
0530	6501.0	USCG, COMMSTA PORTSMOUTH	NMN	OFFSHORE WX,
0530	8764.0	USCG, COMMSTA PORTSMOUTH	NMN	OFFSHORE WX,
0533	2670.0	USCG, GROUP ASTOROA, OR	NMW	WX, NTM
0545	2670.0	USCG, COMMSTA HONOLULU	NMO	O/S WX, F/CA
0545	6501.0	USCG, COMMSTA HONOLULU	NMO	O/S WX, F/CA
0545	8764.0	USCG, COMMSTA HONOLULU	NMO	O/S WX, F/CA
0550	2670.0	USCG, GROUP NEW ORLEANS, LA	NMG2	WX, NTM
0603	2670.0	USCG, GROUP NORTH BEND, OR	NOE	WX, NTM
0615	2670.0	USCG, GROUP FORT ANGELES, WA	NOW	WX, NTM
0620	2670.0	USCG, GROUP MAYPORT, FL	NMA10	WX, NTM
0705	2670.0	USCG, COMMSTA GUAM	NRV	OFFSHORE WX,
0930	6501.0	USCG, COMMSTA GUAM	NRV	OFFSHORE WX,
1000	4426.0	USCG, COMMSTA PORTSMOUTH	NMN	OFFSHORE WX,
1000	6501.0	USCG, COMMSTA PORTSMOUTH	NMN	OFFSHORE WX,
1000	8764.0	USCG, COMMSTA PORTSMOUTH	NMN	OFFSHORE WX,
1020	2670.0	USCG, GROUP MOBILE, AL	NOQ	WX, NTM, REM
1030	4426.0	USCG, COMMSTA SAN FRANCISCO (CAMSPAC)	NMC	OFFSHORE WX,
1030	8764.0	USCG, COMMSTA SAN FRANCISCO (CAMSPAC)	NMC	OFFSHORE WX,
1030	13089.0	USCG, COMMSTA SAN FRANCISCO (CAMSPAC)	NMC	OFFSHORE WX,
1040	2670.0	USCG, COMMSTA BOSTON	NMF	MARINE WX
1040	2670.0	USCG, GROUP CORPUS CHRISTI, TX	NOY8	WX, NTM
1050	2670.0	USCG, GROUP GALVESTON, TX	NOY	WX, NTM
1050	2670.0	USCG, GROUP NEW ORLEANS, LA	NMG2	WX, NTM

This list, prepared by Richard Baker of Ohio, is the first installment of marine and Notice to Mariners schedules conducted by US Coast Guard CommSta's or Groups.

Sometimes the 'intermod' isn't in the receiver."

When low-band VHF skip is in, Dave Wiechman, CA, can copy WTVM, Columbus, OH on 26250 kHz and WLW, Cincinnati, OH on 26450 kHz. "Incidentally, these are narrowband FM signals. There once were many such channels in use by broadcasters in my area; but most here have now moved to allocations in the 900 MHz portion of the spectrum."

I have mentioned *Jane's Military Communications* publication several times in

the column and as a result I have received queries concerning a source for the book. I presently only know of two places that offer slightly outdated volumes at reduced prices. When a particular volume is first published it is expensive. The 1990-1991 edition for example had a price tag of \$170. However, the edition has been available every so often from Barnes & Noble, 126 Fifth Avenue, New York, NY 10011 and from Edward R. Hamilton, Falls Village, CT 06031-5000. Write to those addresses for additional information.

Richard Baker, OH reports he has had several of his PFC's returned marked, "Unit Decommissioned." Since the call signs have been noted in use they have apparently been reassigned. NNNOCMA is not the John L. Hall; NNNOCYV is no longer USNS Dutton, T-AGS-22; NNNOCTD is no longer USS Henry Wilson; and NNNOCSA is no longer USS Lawrence, DDG-4; NNNOCRJ is no longer USS Talbot, FFG-4; NNNOCUL no longer USS Semmes, DDG-18.

Richard also noted NNNOERA and



NNNOXRA in casual comms advising re notice from AAA9A Chief Army MARS, that their units prohibited from using Navy MARS unless extreme emergency.

#### UTE Loggings. All Times UTC.

**71.43:** Decca Station Zeven (Frisian chain), Germany w/carrier at 0802. (Boender, Netherlands)

**77.50:** DCF77, Time Signal Station Mainflingen, Germany w/time signals at 0805. (Boender, Netherlands)

**85.72:** Decca Station Finstwolde (Frisian chain), Holland w/carrier at 0838. (Boender, Netherlands)

**122.3:** OUA23, Aarhus Naval, Denmark in CW at 1650 w/VVW DE OUA23 mkr. (Boender, Netherlands)

**175:** KRY, Lowfer, Chardon, OH at 1034. (Crabill, VA)

**190:** TH, Lowfer, Colts Neck, NJ at 1048. (Crabill, VA)

**203:** Beacon NSI, San Nichols Island, CA at 1330. (Polhamus, CA)

**205:** Beacon CQA, Celina, OH at 0200. (Vylasek, OH); Beacon COR, Corcoran/Sayler Farms, CA at 1455. (Tomkinson, CA)

**209:** Beacon IKB, Wilkesboro, NC at 1213. (Crabill, VA); Beacon HCD, Hutchinson, MN at 0434. (Vylasek, MN)

**210:** Beacon MY, Montgomery Field, San Diego, CA at 0910. (Tomkinson, CA)

**212:** Beacon SSQ, Shell Lake, WI at 0438. (Vylasek, MN)

**227:** Beacon SJY, San Jacinto, CA. (Polhamus, CA)

**245:** Beacon TLR, Tulare, CA at 1221. (Vaage, CA)

**253:** Beacon UR, Burbank, CA at 0658. (Vaage, CA)

**257:** Beacon LKA, Chino (Swan Lake), CA. I hear this 24 hrs per day. (Tomkinson, CA)

**269:** Beacon AHX, Athens, TX at 1846. (Low, TX)

**275:** Beacon ING, Philadelphia, PA at 1234. (Crabill, VA)

**277:** Beacon CHT, Chiltern, UK at 0609. (Sevart, England)

**279:** Beacon Y, u/i at 0327. (Sooy, Sr., NJ) Wonder if this is Scatarie Island, NS, Canada which was on 286 & then moved to 300 kHz and perhaps has now moved again?? (Ed.)

**289:** Beacon MR, Marina Del Rey Light 3, CA at 0702. (Vaage, CA)

**293:** Beacon PH, Penzance, UK at 0611. (Sevart, England)

**298:** Beacon HL, Cape Henlopen, DE at 0333. (Sooy, Sr., NJ)

**308:** Beacon UTS, Huntsville, TX at 1820. (Low, TX)

**311:** Beacon OE, Heathrow Airport, London, UK at 0619. (Sevart, England)

**316:** Beacon AC, Atlantic City, NJ at 0335. (Sooy, Sr., NJ)

**319:** Beacon RB, Redondo Beach West Jetty Light 3, CA at 1242. (Vaage, CA)

**322:** Beacon LCY, London City, UK at 0624. (Sevart, England)

**333:** Beacon STT, Mountain Home, ID. I used to live 2 miles from this beacon. It threw harmonics above 2 MHz. (Tomkinson, CA)

**335:** Beacon PV, Providence, RI at 0230. (Sooy, Sr., NJ); Beacon RWN, Winamar, IN at 0503. (Vylasek, OH)

**338:** Beacon GE, Gatwick Airport, London, UK at 0636. (Sevart, England) Beacon LH, Lancaster, OH at 0500. (Vylasek, OH)

**346:** Beacon PCM, Plant City, FL at 1141. (Crabill, VA)

**350:** Beacon RG, Oklahoma City, OK. Wx on voice at 1205. (Crabill, VA); Beacon DF, Deer Lake, Nfld., Canada. (White, ME)

**363:** Beacon RNB, Millville, NJ at 0354. (Sooy, Sr., NJ)

**363.5:** Beacon CT, Coventry, UK at 0652. (Sevart, England)

**367:** Beacon HA, Hao Atoll/Tuamotu Island, Fr. Polynesia at 0825. Almost a 'regular' due to its hi-pow-

Wellington Radio/ZLW is owned and operated by Telecom International, a subsidiary of Telecom Corporation of New Zealand Limited. The station operating room is located within the city of Wellington in position 41.16.26S 174.45.55E (these are the co-ordinates of our MF tx used for maritime mobile Distress and Safety services).

The station occupies a 22 hectare site some 300m above sea level and enjoys a panoramic view of the harbour, city and environs. Wellington Radio antenna towers have been a feature of the Wellington skyline since August 1912. Operating staff numbers are 10.

We provide Maritime Mobile Distress, Safety and Message services on frequencies from 2mHz to 22mHz utilising voice, telex and morse modes. We also provide HF fixed point services to Campbell Island, Raoul Island and Pitcairn Island which are simplex USB circuits offering voice communication only.

All of ZLW HF tx are at Himintangi in position 40.23S 17518E, some 70 km north of Wellington. All receivers are at Makara 6.5 km North West of the operating room. Remote control is extensively employed.

*This ZLW information was received without the name of the contributor. Thanks to whoever sent in this item.*

er output, 5kW! (Tomkinson, CA)

**370:** Beacon Paicoma (Barton Heliport), CA. (Polhamus, CA)

**373:** Beacon EP, Estevan Pt., BC, Canada at 0842. (Tomkinson, CA)

**379:** Beacon CM, Channel Head (Mouse Is.) Nfld, Canada. (White, ME)

**380:** Beacon ML, Milledgeville, GA at 0604. New freq: ex-359 kHz. (Crabill, VA)

**386:** Beacon GMA, Dalton, NH. (White, ME)

**388:** Beacon MCR, Manchester, UK at 0703. (Sevart, England)

**395:** Beacon XEN, Xenia, OH at 0210. (Vylasek, OH)

**397:** Beacon MXO, Monticello, IA at 1112. (Crabill, VA); Beacon SB, San Bernardino (Norton AFB), CA at 1321. (Vaage, CA); Beacon J, St. John, NB, Canada. (White, ME)

**403:** Beacon AXA, Algona, IA at 1109. (Crabill, VA)

**407:** Beacon RIE, Rice Lake, WI at 0605. (Vylasek, MN); Beacon H, Montreal, PQ, Canada. (White, ME)

**408:** Beacon MVV, Moses Lake, WA at 1327. (Vaage, CA)

**414:** Beacon OEG, Yuma Proving Grounds/ Golden Eagle, AZ. Ex-LGF. Hrd at 0900. (Tomkinson, CA)

**417:** Beacon HHG, Huntington Municipal, IN at 0550. (Vylasek, OH)

**444.5:** PCH, Scheveningen, Holland in CW w/tfc list at 1650; FFB, Boulogne-Sur-Mer, France in CW at 2235 w/navigational wrngs. (Boender, Netherlands)

**489:** VCM, St. Anthony, Nfld, Canada w/Canadian CG wx bcst. (White, ME)

**517:** Beacon CWA, u/i, vy weak at 0429. (Sooy, Sr., NJ) Cud this be YWA, Petawawa, Ont., Canada on 516 kHz?? (Ed.)

**526:** Beacon RWE, Camp Roberts/San Miguel, CA. (Polhamus, CA)

**1148:** CHU, Canadian time station at 1149. (Sooy, Sr., NJ)

**2182:** Various vessels checking in w/Pusan, S. Korea radio at 1350 in USB. (Sabo, S. Korea)

**2278.9:** U/i OM/EE outbender on freq in USB at 0022. Was singing songs then started screaming & later back to singing. He then played the harmonica. (Sevart, England)

**2598:** VOJ, Canadian CG, Stephenville at 0704 w/wx, foll by VOO Comfort Cove at 0811 and VCP, St. Lawrence at 0821. All in USB. (Baker, OH)

**2670:** USCG CAMSPAC, San Francisco, w/wx & various District 11 notices to mariners. USB 1405-

1411. (Sabo, S. Korea)

**2702:** Coastal Control wkg Golf Kilo (Royal Navy) in USB at 0037. (Sevart, England)

**2749:** VCN, Cap-Aux-Meules, CG, Canada in USB w/marine wx advisories in FF then EE at 0507-0510. (Caldicott, MA)

**2870:** Russian VOLMET stns Novosibirsk at 0213, Kuibyshev at 0215, Sykvytar at 0230, and Yekaterinburg at 0235. All USB. (Boender, Netherlands)

**2941:** Moscow Volmet in USB at 0140 w/wx in RR. (Sevart, England)

**2998:** Naha, Okinawa Aeradio wkg Northwest 94 in USB at 1356. (Sabo, S. Korea)

**3228:** YL rping Echo Lima from 1930-1935, then 5F GG text for 063 and 928. (Mason, England)

**3251:** U/i CW stn sending 5F grps w/unusual characters at 0347. (Sevart, England)

**3252.5:** U/i CW stn w/5F grps w/unusual characters at 0210. // with 3641 kHz. (Sevart, England)

**3253:** NIKI, USCGC Tampa (WMEC-902) wkg NRZI, USCGC Sorrel (WLB-296). Tampa relaying comms to USCG Group Woods Hole from Sorrel re distressed F/V Sea Grass (?). Pumps not keeping up w/water. unable estimate water per hour, it's coming in too fast. Group Woods Hole req F/V activate EPIRB (Emer. Position Indicating Radio Beacon). At 2328 Tampa relays further sitrep, engine room flooding, adv Sorrel Helo will be airborne shortly. Req position of F/V every 10 mins. USB mode. (Baker, OH)

**3262:** New ZL station. YL/GG rping Romeo Delta w/electronic tones from 2000-2005. 5F traffic was for 041/12, 116/40, 208/33, and 457//24. Rptd next day at 1900 on 4543 kHz. (Mason, England)

**3270:** YL/EE Mossad stn rping KPA2 at 0214. (Sevart, England)

**3455:** Tokyo Aeradio wkg Singapore 11 in USB at 1404, Philippine 104 to Tokyo w/position report at 1413. (Sabo, S. Korea)

**4024:** At 2000 CW NNN being sent. Then at 2005 YL/GG w/Gruppe 30 x2 & into 5F grps. (Mason, England)

**4030:** YL/SS in SSB at 0515 w/4F grps til 0520. (Sooy, Sr., NJ)

**4032:** U/i stn in MCW at 0406 w/5F grps. Ended w/AR, sent GR 30 & rptd msg. (Sevart, England)

**4149:** Two OM/EE in USB at 0527 w/maritime comms. (Low, TX)

**4373:** Bravo Whiskey & Alpha Alpha in SSB at 0535 w/military comms, possibly ground troops. (Sooy, Sr., NJ)

**4384:** VAI, Canada CG, Vancouver w/wx for Ber-

ing Sea, Gulf of Alaska, and offshore waters west coast. USB mode. (Baker, OH)

**4420:** "Dripping Water" sound at 2125. Signal occupied 4415 to 4450 kHz. (Sevart, England)

**4463:** YL/EE Mossad stn FTJ at 0200. (Sevart, England)

**4538:** YL/EE w/1-0 count and '885' from 2100-2110. After ten tones 'count 70' and into 3/2F grps. (Mason, England)

**4543:** YL rptng Papa Zulu from 2100-2105 then 5F grps in German for 625 and 374. (Mason, England)

**4560:** At 0505 CanForces Naval Station, Halifax Military W/HMCS Toronto (FFH-333), helicopter fast frigate, using id Warship Toronto. Comms re encoded msg. Also hrd at 0556. USB mode. (Baker, OH)

**4580:** OM/EE w/RR accent rptng 152 form 2100-2105. Then 485 x2, 95 x2 and into 5F grps. Ended w/00000. (Mason, England)

**4603:** SLHFM 'P' at 2010 w/unusual format. Letter P sent in pairs, i.e., P-1 sec gap P, P-2 sec gap P, P-1 sec gap P, etc. (Mason, England)

**4663:** Khabarovsk VOLMET in USB from 1137-1140 YL opr w/heavily accented EE. (Sabo, S. Korea)

**4746:** USAF comms at 0545. OM/EE w/status & time of tankers requested, also rendezvous area wx. Dover mentioned & it suspected that Dover AFB was the ground stn for above comms. (Sooy, Sr., NJ)

**4870:** Warbling jammer at 0249 moving back & forth from this freq & 4880 kHz. (Sevart, England)

**4880:** At 1900 YL/EE w/ULX at quite a fast delivery. When YL said "Message x2. Group 10b x2" er voice went very "leap and slow but speeded up when the 5L text was sent." (Mason, England); ULX x2 JSR on same freq at 1900 later. JSR stopped and ULX sent a msg. (Sevart, England)

**5000:** RCH, Tishkent, USSR. Time signal stn in CW at 2359 (Sevart, England)

**5301:** OLX, Prague w/5F msg in CW at 0000. Had faulty xmtr. OLX has moved back to original freqs of 5301, 6758, and 8142 kHz. (Sevart, England)

**5310:** MB (Control stn) in USB at 2305 wkg A9F, X1E, 4GS and 5AO w/comms concerning boarding and diversion of u/i motor vessel. A9F and X1E were to board vessel and 5AO was to escort vessel to Brindisi, Italy. MB opr had UK accent, A9F French, X1E & 4GS American and 5AO Italian. Active almost every evening. (Rausch, NJ)

**5315:** YL/GG rptng 435 x3, 08712, 027 from

1900-1905. After 5 tones into 5F grps. Also on 7830 kHz. (Mason, England)

**5367:** 437, u/i stn in CW w/5F grps. Msg header: 1 555 85. Hrd at 2045. (Boender, Netherlands)

**5413:** At 2003 CW stn sending VVV DE VOE. u/i. (Mason, England)

**5502:** YL/Chinese w/short recorded phrase of 4 syllables rptd x3. Preceded by a rush of white noise. Hrd 2000-2005. (Mason, England)

**5503:** 234 rptd in CW at 2218. At 2220 sent BT 91 43 and into 5F grps. At end of msg rptd 234 call msg. Signed down w/000. (Sevart, England)

**5526:** At 0628 American 956 wkg Maquetia Aeradio, Venezuela (NE-SAM), w/position & flight info. At 0636 American 904 w/same. foll by American 950 at 0637. All USB. (Baker, OH)

**5598:** French Line 647 w/Santa Maria at 0830, leaving FL 290 for 350; Martinair 652 (Punta Cana-Amsterdam) w/S. Maria giving position report at 0837; Lufthansa 499 wkg S. Maria at 0900 w/position report. All USB. (Boender, Netherlands)

**5643:** Qantas flight 3 wkg Honolulu w/position check at 0838. (Spurway, Australia)

**5651:** At 2000-2004 OM/EE w/897. Then 452 x2 61 x2 and into 5F grps. Ended w/00000 and rptd at 2100 on 4660 kHz. (Mason, England)

**5673:** Beijing VOLMET in USB from 0927-0930. Voice of YL computer-generated in CC. (Sabo, S. Korea)

**5680:** Scrambled speech in USB at 2315. At 2330 Edinburgh Rescue wkg Rescue 177. (Sevart, England)

**5690:** At 1920 CW stn sending 748 x3, 00000 Zero was cut to T. This was machine sent CW. (Mason, England)

**5696:** USCG 1501 w/pp to D5 Ops at 1613. V/ was asked to search for a 67' schooner type sailing vessel w/name of Rachael B. Jackson. D5 said vessel may have radio probs. Known to have probs in past. 1501 was also asked what the best detection device was onboard a/c. Pilot responded he had been searching assigned area w/normal 5 mile track space but can provide wider sweep w/radar if requested. According to pilot, radar can even detect wooden hull quite adequately. 1501 terminated comms w/mgs that he leaving for next southern quadrant. (Caldicott, MA)

**5758:** YL/SS in SSB at 0409 w/5F grps. Off at 0420. (Sooy, Sr., NJ)

**6224:** Marine comms in SS at 0434, discussing

VHF CH to use, fog & river conditions. Other marine comms on other nights in various languages. (Sooy, Sr., NJ)

**6236:** Comms on this freq believed be by units involved in USCG Haitian Ops. Hrd CG 1719 (C-130), NRP, USCGC Legare (WMEC-912), NJOR, USCGC Gallatin (WHEC-721), NICB, USCGC Forward (WMEC-911), CG 1710 (C-130) CG 1720, u/i a/c, NROS, USCGC Spencer (WMEC-905). Spencer advised use this freq as primer, "3C7" as secondary. All in USB mode. (Baker, OH)

**6507:** Swedish Rhapsody tune at 2001 on AM. Rptd until 2005. Then YL/GG 5F grps. (Sevart, England)

**6679:** Hong Kong VOLMET. YL opr in USB 1246-1250. // w/ 8828 kHz but copy on 6679 was much better. (Sabo, S. Korea)

**6730:** Contender ckg Outplay (both USAF tactical call signs) on "X903." Then requests he go secure. Outplay advised QSY to "X904." USB at 0441. (Baker, OH)

**6736:** U/i OM/SS in SSB at 0441. Freq listed as drug running/smuggling activities. Next night OM/SS w/short transmissions then into EE military type comms (Xray Alpha Foxtro, etc.) w/short trnsmns sounding like surveillance setup. Next night at 0413 hrd similar comms w/phonetic ltr & nbr calls for more than 1/2 hour. (Sooy Sr., NJ)

**6738:** Offurt to MAINSAIL w/EAM bcst in USB at 0823. // w/11176 and 13201 kHz. (Sabo, S. Korea)

**6773:** Nbr stn 378 in CW at 2157. Header: 1 154 27. 5F grp text. 1=nbr of mgs. 154=key. 27=GR count. (Boender, Netherlands)

**6798:** YL/SS at 0600 w/Attention 753, 02. Then 02, 130 & into 5F grps until 0619. Then two "Final's" and immediately more 5F grps. At 0628 one "Final" and off. (Mazanec, OH)

**6840:** YL/SS in AM at -235 w/4F grps. (Sevart, England)

**6853:** YL rptng Whiskey Lima w/electronic tones from 1900-05. At 1905 026 026 42 Gruppen und 22 Gruppen, 522 522 22 Gruppen. Then into German 5F grps. YL/EE rptng Mike Delta 2000-05. Then Message for 241/29 331/44 017/36. 'Attention' then into EE 5F grps. (Mason, England)

**6995:** 5F grps in CW at 0511, ended w/AR. (Sevart, England)

**7375:** YL/GG at 1702 in AM rptng 170 170 170 61376 031. At 1710 five tones and into 5F grps. (Sevart, England)

**7421.5:** USCGC Naushon wkg COMMSTA New Orleans at 0622 re poor comms poss due to heavy tx. Naushon has a listed homeport in Alaska. (Rausch, NJ)

**7425:** YL/SS in AM at 0425 w/4F grps. V/ weak w/QRN due to storm. (Dutcher, NY)

**7450:** YL/EE rptng 4161, 9528, 5505 at 0030. Next night YL/EE rptng 0014, 8353 at 0030. (Soderlund, RI)

**7495:** YL/EE rptng 2539, 9101, 5171 at 0030. (Soderlund, RI)

**7535:** Following ships hrd on USN Norfolk SESEF primary. At 1559 u/i sub using call "In Port Navy Unit" for xmtr test; 1609 radio test w/NGHY. US Peterson (DD-969): 1700 NTGS. USS Spartanburg County (LST-1192). xmtr tests: 1821 NIHL, USS Opportune (ARS-41) radio ck then to UHF to ck xmtr; 1854 w/u/i ship using tac call 3 Charlie Juliet, xmtr tests; 1921 ckg USS Posse??; 1936 wkg u/i USN ship using tactical call of Quebec 7 Whiskey; all comms USB. (Baker, OH)

**7635:** Norfolk, VA SESEF in USB at 1922 wkg NCGD. USS Mississippi (CGN-40). (Margolis, IL)

**7875:** In here at 1950 when OM/EE was sending 5F grps. Ended w/328 x2 51 x2 00000. (Mason, England)

**7887:** YL/EE in USB at 0605 rpts 50472 + Vive la Compagnie tune. At 0610 hi-lo tones sent foll by 5F grps w/each grps twice. Poss tape splice at 0613? "2- (pause then short tone) 9929" and continues msg. (Margolis, IL)

**7918:** YL/EE Mossad stn rptng YHF2 w/unid OM mocking it on the same freq. (Sevart, England); YL w/5L grps in USB at 1627. Mossad YHF channel. (Sabo, S. Korea)

**8136:** YL/SS in AM at 0504 w/"Atencion" rptd 0508 5F grps w/o beeps or Grupo beforehand. She sounded as if she had a speech impediment. Her voice hrd on every freq between 8125 & 8156 kHz. (Margolis, IL)

**Complete Your Collection of Popular Communications. Order Your Back Issues Today!**



Mail all correspondence to:  
**CQ Communications**  
76 N. Broadway, Hicksville, NY 11801  
Phone: 516-681-2922 FAX: 516-681-2926

**Somerset Electronics, Inc.**  
A Whole Lot More For Your Money!  
**Microdec™ Multi Mode Decoder (\$199.95)**  
**VIP50 Interface Adapter (\$189.95)**



**Special Combo Price - \$369.95**

\*\*Prices do not include applicable sales taxes.  
\*\*Prices/specifications subject to change without notice\*\*

**Somerset Electronics, Inc., 1290 Highway A1A, Satellite Beach, FL 32937**

**Decode:** Morse w/auto speed, speed display, practice mode, software filter.  
**RTTY:** 60, 67, 75, 100 WPM w/major shifts and bit inversion.  
**AMTOR/SITOR:** Mode A-ARQ; Mode B-FEC  
**Features:** Compact size (1.3"hx5.1"wx5.3"d), smart display w/intensity control; on/off power, internal speaker, volume control, serial interface(to computers), code practice oscillator.  
**OPTIONS:** VIP50 interface adapter: Displays 32 characters per line, x 16 lines on your NTSC TV plus parallel dot matrix printer interface (\$189.95).  
Rechargeable battery pack for portability (\$39.95)  
Tuner option (\$39.95)

Please call us with your order at 1-800-678-7388.  
Technical assistance and fax orders: 1-407-773-8097  
\*\*We accept VISA • MasterCard • Personal checks • Money orders\*\*  
Please add \$10.50 for domestic s/h.

CIRCLE 120 ON READER SERVICE CARD



**8240:** Yacht Nuclear Electric w/Portishead Radio at 0649 conducting phone interview re leading in race. All w/very English accents. Electric being picked to win race. (Baker, OH): British aircraft carrier "Warship Ark Royal" (GCDG. R07) w/rptd calls to Portishead in USB from 2026-2033. (Sabo, S. Korea)

**8294:** Two OM (prob Greek) in SSB at 0443 w/fishing conversation. catch mentioned, some EE conversation. (Sooy Sr., NJ)

**8298.5:** USB Net at 2217 w/New England, Sea Lab, Laptop Alfa & Morning Light. All u/i. Net switched to 6 MHz band at 2230. (Margolis, IL)

**8300:** Chinese numbers station "New Star Radio Station Number 4" signing on, then into YL/CC 4F grps, each x2. AM mode at 1103. Similar, but non-parallel bcst noted on 11430 kHz in AM at 1108. (Sabo, S. Korea)

**8562:** PCH40, Schevevingen. Holland in CW at 1445 w/DE PCH40 mkr. (Boender, Netherlands)

**8604:** DJJ, Bulacan, Philippines at 1320 in CW clg CQ 6/12/16 MHz. (Caldicott, MA)

**8641:** YL rpts MIW2 in USB at 2018. (Sabo, S. Korea)

**8690:** 3DP, Suva, Fiji Islands w/CW mkr CQ DE 3DP... at 0920. (Dos Anjos, Brazil)

**8719:** At 2403 Cape Town, S. Africa starting 2nd R/T call for u/i vessel advises him ch. 1221 best days. At 2108 USS Opportune (ARS-41) w/COMSUPRON 8 for rdo ck on USN primary "Salvage" channel. Little Creek, VA. USB mode. (Baker, OH)

**8739:** YL/EE in SSB at 0523. Has strong accent. Reading freq list then into SS at 0525 with freq list. (Sooy Sr., NJ)

**8752:** KVH, NOAA Atlantic Marine Center w/WATER, NOAA Ship Malcolm Baldrige (R-103) at 1801 in USB re admin comms. (Baker, OH)

**8849:** Beijing VOLMET in USB at 0115. Was computer-generated OM voice in EE. // w/13285 kHz. (Sabo, S. Korea)

**8873:** YL/SS in AM at 0914 w/5F grps. (Lundquist, IA)

**8888:** Luanda, Angola in USB at 0350 in contact w/Namibia 662. (Dos Anjos, Brazil)

**8894:** Algiers Air in USB at 0147 wkg Lufthansa

flt. 569 at flight level 390. 569 requested Algiers provide "Bravo Kilo" (tone). When signal rcvd, 569 stated eta at 0203. At 0150, Alitalia flt 812 requested permission for level 330. (Caldicott, MA)

**8903:** N'Djemena, Chad Air rdo & Niamey, Niger Air rdo in USB w/kg several flts across Africa. Hrd 0005-0035. Luanda, Angola can also be hrd this freq. (Caldicott, MA)

**8933:** Jo berg Radio hrd wkg various Springbok flights in USB between 1959 & 2005. Good copy on Jo berg, tho I could barely make out the a/c. (Sabo, S. Korea)

**8967:** Reach 2103 wkg Dhahran, Saudi Arabia metro via PP from Andrews AFB in USB at 2308. (Rausch, NJ)

**9013:** Aerolineas Argentinas. Bs. Aires in contact w/Argentina 319 at 1221 in USB. (Dos Anjos, Brazil)

**9106:** British Antarctic Survey. t/c between Signy & Faraday in USB at 2345. (British Bases in Antarctica). (Dos Anjos, Brazil)

**9130:** YL w/5L grps in USB at 1737, strong sigs & // 6840. Hrd on other days at 1627 & 2009 w/similar t/c. (Sabo, S. Korea)

**9222:** YL/SS in AM w/928(x3). 1-0 count. rptd at 0303. (Low, TX)

**9831:** YL/EE in AM at 1429 w/3+2F grps. non-parallel YL/EE w/2+3F grps noted on 10723 kHz at 1432. (Sabo, S. Korea)

**10046:** 4XZ, Haifa, Israel w/VVV mkr at 0238. (Low, TX)

**10066:** A/c EWW-802 reports position WINSLOW, flight level 370 to Kunming, PRC Aeradio at 1147. Kunming advised a/c to make contact via VHF 133.6 MHz. A/c carried Reg. N791FT & headed for Hong Kong. Calcutta Aeradio took over & wrkd a/c at 1148. All USB mode. (Sabo, S. Korea)

**10177:** YL/GG in USB at 0145 w/3-2F grps. (Margolis, IL)

**10262:** YL/EE in AM at 1422 w/4+2F grps, //13906 kHz. (Sabo, S. Korea)

**10940:** YL/EE in AM at 1134 w/4F grps. YL/EE w/3+2F grps hrd most often so this was quite out of the ordinary. (Sabo, S. Korea)

**11002:** VVV DE OLX in CW from 1455-1500

follow by YL/Czech rptng '374' until 1505 then into 5F grps. Also on 6758/5301 kHz. Unable to QSL this former CETEKA Press station. (Mason, England)

**11176:** USAF in Mogadiscio, Somalia asking for contact at 2320 in USB. (Dos Anjos, Brazil)

**11300:** Addis, Ethiopia in contact w/Mauritius 057 in USB at 0050. (Dos Anjos, Brazil)

**11345:** Transavia PH-HVJ (Las Palmas-Amsterdam) w/Stockholm in USB at 0000 w/pp to Transavia Ops. A/c delayed due strong head wind & has insufficient fuel reach Amsterdam. Wants to divert to Rotterdam or Brussels. At 1240 VJ calls again telling that it will divert to Brussels. eta 1340. At 1303 VJ checks into cancel Brussels, they cannot make it and are now heading for Paris. De Gaulle. At 1310 Transavia Ops calls VJ to confirm the fuelstop at Paris. (Boender, Netherlands)

**11397:** Lineas Aereas Paraguayas Company freq. Asuncion wkg LAP 242 w/altitude position report at 0109 in SS. (Rausch, NJ)

**11470:** YL/EE in AM at 1209 rpts "989 989 989" and 1-0 counts til 1210, then 10 beeps, "Count 225" x2 and into 3/2F grps. Noted //16198 kHz at 1250. (Sabo, S. Korea)

**11553:** At 0204 weak comms. OM/EE's believed be Palmer Station, Antarctica wkg other u/i & weaker stn. At 0501 same comms. 0602 Palmer w/u/i stn, poss McMurdo re pack ice, ie patrol, & msg for worker in water plant. USB mode. (Baker, OH)

**12070:** WUG, Army Corps of Engineers, Lower Mississippi Valley wkg WUE6. COE Nashville, TN in USB at 1705. (Margolis, IL)

**12221:** YL/EE in AM at 1230 w/3+2F grps; rptng w/typical "count 225" at 1231. Strong, clean sigs and //13555 kHz. (Sabo, S. Korea)

**12356:** KZU, Gulf Mississippi Marine Co., Harvey, LA wkg vessels w/callsigns of WYT8732 & WBE5863. (Margolis, IL)

**12800:** HSA3/24, Bangkok, Thailand in CW at 1245 clg CQ foll by rptd t/c list at 1250. Note: This stn scheduled to xmit lists on HR+00. (Caldicott, MA)

**12829.5:** XFM, Manzanillo, Mexico in CW w/wsx. Heavy side-band QRM from WNU, Slidell, LA. (Caldicott, MA)

# SR STANDARD®

## CCR708A



VHF - UHF  
WIDEBAND  
50.000 MHz TO  
904.995 MHz  
SPECTRAL  
DISPLAY SCOPE  
COMMUNICATIONS  
TEST RECEIVER

- Continuous full coverage: 50-904.995 MHz.
- Receiving mode: Amplitude Modulation (AM), Narrow Band Frequency Modulation (N-FM), Wide band Frequency Modulation (W-FM).
- High precision/high stability PLL synthesizer.
- Microprocessor controlled.
- 100 storage channels for quick frequency reference- direct entry.
- 120 volt 60 Hz wall transformer included.
- Ideal for the service bench.
- Compact size- perfect for portable field use.
- Equipped with a LCD spectral display scope used for evaluating signal strength and tracking down nearby interfering signals.
- Extremely well built to industry standards.
- Its versatility/portability allows the technician to evaluate other equipment.
- Supplied with a telescoping antenna.

STANDARD Amateur Radio Products, Inc. • P.O. Box 48480 • Niles, IL 60648 • (312) 763-0081

## SPY ON THE EARTH



See live on  
your PC  
what  
satellites in  
orbit see

Learn how you can benefit greatly from this exciting new technology. Send \$30 (\$35 air, \$40 overseas) for our fantastic 12 diskette set of professional quality copyrighted programs (IBM type) that does satellite tracking, data acquisition, image processing, file conversion and much more. Diskette and information package includes all programs, satellite views, C language source code for a popular satellite image acquisition program, hardware schematics, catalog and discount certificate.

**VANGUARD Electronic Labs**  
Dept. PC, 196-23 Jamaica Ave.  
Hollis, NY 11423 Tel. 718-468-2720

# MARYMAC

## The New Realistic® PRO-43 Scanner

### Radio Shack

Phones

Our 17th Year of DISCOUNTS

Freight prepaid, save tax

**Toll Free 800-231-3680**

PRO-43 List \$349.95

Our Delivered Price \$298.00

"We discount everything in the RS catalog"

22511 Katy Fwy.

Katy (Houston), TX 77450

1-713-392-0747 FAX 713-574-4567

CIRCLE 69 ON READER SERVICE CARD



When  
seconds  
count,  
**REACT®** needs you...

...to summon help for an injured motorists, an elderly woman trapped in a fire, a trucker stranded in a blizzard, a drowning child!

As a REACT volunteer CB radio monitor you may be the only communications life-line for someone in serious trouble. You relay messages from those desperate for help to police or other emergency services.

Your REACT Team will also use CB and other radio services to provide safety communications for events like parades, marathons and even balloon races. The fellowship with other REACT members at Team meetings and annual conventions is an added bonus.

Volunteer. Join Today!

**Add a New, Exciting  
Challenge to Your Life.  
Help Save Lives  
and Property!**

**REACT® International, Inc.**

Tel (316) 263-2100

FAX (316) 263-2118

P.O. Box 998, Wichita, KS 67201



CIRCLE 72 ON READER SERVICE CARD

**13077:** Voice mirror w/id of BA, Taipai in USB in EE & CC from 0258-0300. Anyone have a QSL address for this station? (Sabo, S. Korea)

**13446:** Rich Lady. USAF Tactical callsign, wkg FEMA WGY908. Denver, CO in SUB at 1607. (Margolis, IL)

**13543:** LBL1, Norwegian Forces w/UN in Beirut, Lebanon in USB at 1358. OM Opr w/Norwegian language comms. (Margolis, IL)

**13775:** YL rptng Golf Charlie w/electronic tones from 1130-35. Then 5F GG msgs for 334 & 808. (Mason, England)

**13974:** USN MARS. At 2149 NNN0CNA, USS Tripoli (LPH-10) wkg NNN0PSX w/pp tfc. Tripoli is off coast of Somalia in Op Restore Hope. At 2206 NNN0CVN, USS Briscoe (DD-977) wkg NNN0PSX w/pp tfc in USB. (Baker, OH)

**14772:** RIW, Khiva Navrad, Uzbekistan in CW at 1237 w/cut nbr tfc using ANDUWRIGMT. (Margolis, IL)

**14945:** YL rptng Lima Uniform between 1130-35 foll by 5F GG for 031 of 91 grps length. (Mason, England)

**15015:** USAF/GCCS. At 1715 AGAR 94 heavy clg McClellan w/no joy. USB mode. (Baker, OH) AGAR + # listed as EC-139 a/c. (Ed.)

**15920:** CFH, Halifax, NS, Canada in CW at 1830 w/NAWS (Notice to all Allied Warships) information. (Low, TX)

**15970:** KKN50. US Dept of State w/QRA/QSX mkr at 2234. (Low, TX)

**15980:** YL/EE rpts Echo Zulu India in USB at 1802. At 1804 into 5L msg using phonets. (Margolis, IL)

**16084:** YL/EE rpts 59687 & 'Vive la Compagnie' tune. At 1610 hi-lo tones octave apart, foll by 5F grps. All hrd at 1734 on another day. (Margolis, IL)

**16180:** NMN. USCG Portsmouth, VA in CW at 2240. (Low, TX)

**17190:** LSA. Boca, Argentina in CW at 0017 w/nx in SS. Down at 0042. (Margolis, IL)

**17245/16363:** At 1700 Portishead, GKT62, advising u/i vessel C6HJ7 he was #1, MNLM is #2, and ELDM9 is #3 on freq for R/T tfc. At 1717 Portishead wkg GQIM, HMS Herald (A-138), Royal Navy Survey vessel for R/T tfc, also u/i ves ZJL4743. At 1804 hrd KMI, Dixon, CA wkg ves Navigator for R/T tfc. (Baker, OH)

**17485:** YL/EE hrd w/3+2F grps in AM from 0138-0140. (Sabo, S. Korea)

**18434:** U/i CW stn at 1532 w/TD TR RIW rptd several times then TD UT TD UT TD BT BT BT and into 5L (cut nbrs) groups. (Ed.)

**18630:** CLP1, MFA, Havana, Cuba in CW at 1456 w/tfc in SS. (Margolis, IL)

**18660.2:** U/i CW stns at 1940. UP DE AT in CW then shifts to voice (u/i language) w/brief callup then back to CW w/UP UP DE AT QSA 4/5. Nil more hrd. (Ed.)

**19005.2:** CLP44, u/i Cuban Embassy DE CLP1, MFA, Havana, Cuba at CW at 1835. CLP1 tells 44 to QSV. Nil more hrd. (Ed.)

**19113:** USB at 1458 a 440 Hz tone every two secs; 1459 every sec w/double tones every 10 secs. 1501 every sec but 440 Hz tone on odd secs & 880 Hz tone on even secs. 1504 back to 440 Hz tone every two secs & rpts above pattern. Hrd during periodic checks throughout the day. (Margolis, IL)

**20186:** USB at 1525 phone ringing. YL/EE answers "Patrick AFB, Operator." (Baker, OH)

**20192:** OM's/EE w/comms 1549 "General wants to move on this" re team ckng for QRM from FM radio transmissions. At 1600 phone rings & is answered "Patrick AFB. Opr #16" & call routed to "Depot at 1549 Research Wing" after OM gives number. LSB mode. (Baker, OH)

**20368:** YL/EE in AM at 0326 w/3+2F grps. //22970 kHz. (Sabo, S. Korea)

**21395:** WA3NAN in USB at 1857 w/relay of STS-54 (Endeavor) comms w/Mission Control. (Low, TX)

**21984.9:** Honolulu Aeradio in USB at 0031 wkg u/i re Continental flights 905 & 906 departing Truk at 0011 and 0023. (Sabo, S. Korea)

**22609.2:** U/i CW stn w/nx in SS at 1958. (Ed.)

**22696:** EHY, Madrid, Spain wkg u/i vessel in USB at 1710 for R/T calls in SS. (Baker, OH)

**28195:** IY4M Amateur Beacon in Bologna, Italy hrd at 1615 on CW. (Dos Anjos, Brazil)



# WASHINGTON PULSE

## FCC ACTIONS AFFECTING COMMUNICATIONS

### **Unlicensed Ham Radio Operator Receives Second Felony Conviction**

Richard A. Burton, an unlicensed radio operator, was found guilty of unlicensed operation for a third time in Federal District Court in Los Angeles. A jury found the defendant had violated Sections 301 and 501 of the Communications Act regarding unlicensed amateur radio operation. The latest conviction is Mr. Burton's second felony conviction. Burton had been convicted of similar violations in 1982 and 1990.

Mr. Burton made unlicensed radio communications in the two meter Amateur Band from his vehicle in Redondo Beach, California, in July 1992.

The FCC had suspended Mr. Burton's radio operator's license in September 1981 for violation of several FCC Rules and Regulations. Shortly thereafter, evidence of his continued radio operation was obtained by the FCC's Los Angeles Office. At the time of his first conviction he was sentenced to six months in prison and placed on probation for five years. He was convicted again on July 20, 1990, and was fined \$2,000 and placed on probation for one year.

For his latest offense, Burton was sentenced on February 22, 1993, to seven months in custody by U.S. District Judge Ronald S.W. Lew. Mr. Burton also was given a one year probation period and has to perform 500 hours of community service and undergo psychological counseling.

### **Licensee Denied Review Of Request For Withdrawal and Expunction of Documents**

The Commission denied John Joseph McVeigh, Esq., on behalf of his client, Richard A. White Jr., review of an action by the Field Operations Bureau which dismissed McVeigh's petition for reconsideration. McVeigh, on behalf of his client, requested withdrawal and expunction of documents from White's files. White is the licensee of amateur station KA3T.

This proceeding began when the Engineer-In-Charge (EIC) of the FCC's Norfolk, VA, office notified White of an apparent violation of the rules by retransmitting to another amateur station a packet radio message that appeared to facilitate the business activity of an organization known as "The Coalition to Stop U.S. Intervention in the Middle East." After an exchange of correspondence, the EIC advised McVeigh

that no further action would be taken in the matter because it appeared that steps had been taken to assure that no packet message addressed to all amateur stations in the United States emanated from White's station without prior screening for compliance with the rules. McVeigh was further advised that, because of the corrective action taken, nothing in the record would be prejudicial to the licensee in any future regulatory proceeding and that there would be no expunction from the record of the correspondence exchanged.

McVeigh sought reconsideration of that decision and his request was subsequently dismissed because such petitions lie only where a final action has been taken. Seeking review, McVeigh argued that the Bureau's refusal to withdraw and expunge the record was a prejudicial procedural error. McVeigh believes the EIC erred by stating that the matter was closed because corrective action had been taken and that the question would arise again concerning whether the prohibition against transmission of business messages was violated previously. McVeigh also argued that it was irrelevant, for purposes of reconsideration, whether there was a final action or not and that his client was entitled to an untainted record free of any question concerning the operation of his station.

Denying review, the Commission stated that White had given assurance that no packet message address to all amateur stations in the United States emanates from his station without prior screening for compliance with the rules. His response was considered satisfactory and the matter closed.

The Commission stated further that McVeigh's request to withdraw the original letter and to expunge it and all related correspondence from the record is unwarranted. The FCC does not consider a licensee's file contaminated merely by the presence of an exchange of correspondence between the Commission and the licensee. In this case, the Commission noted that the exchange had been fruitful in that it shows White as a licensee who takes seriously the responsibility for station control and that no useful purpose would be served by expunging the Commission's files.

### **Reduced Forfeiture Amount Assessed**

The Commission issued an \$8,000 forfeiture against Donald W. Bishop, Overland Park, KS, for operating an unauthorized station.

This amount was reduced from \$10,000 which was initially proposed in the Commission's April 1992 Notice of

Apparent Liability. The Commission found that, although Bishop violated the Commission rule prohibiting broadcasting without a license, his prior history of compliance with Commission rules warranted a downward adjustment to the forfeiture amount.

### **The 219-220 MHz Band For Use By The Amateur Radio Service**

In response to a request by the American Radio Relay League (ARRL), the FCC proposed to establish a secondary allocation for the amateur service in the 219-220 MHz band to be used for amateur auxiliary station (point-to-point) packet backbone networks and other amateur point-to-point fixed communications. The Commission also proposed operating limits and other measures to ensure that such amateur operations do not cause interference to primary operations in and adjacent to the 219-220 MHz band.

Packet radio networks are used to transmit digital data in groups or packets using a specified format. Radio channels used by these systems are occupied only during the time individual packets of data are actually being transmitted. Upon completion of a transmission, the channel becomes available for other traffic. Amateurs use packet radio for transmitting a variety of information, including 1) graphic images, 2) computer programs 3) messages and 4) data bases. These systems can be used in times of emergency when other communications facilities are out-of-service or overloaded to efficiently carry a large volume of messages. Amateur radio operators plan to use wideband backbone packet radio networks to provide intercity links of their local packet radio systems.

In its petition, ARRL asked the Commission to authorize access by amateurs on a secondary basis to the 216-220 MHz band for amateur wideband packet networks and other point-to-point fixed communications services. They argued that crowded conditions on their existing bands, particularly in urban areas, prevented completing a nationwide backbone packet network.

The Commission is proposing to authorize amateur wideband packet point-to-point communications and other point-to-point fixed communications on a secondary basis in the 219-220 MHz band. The commission believes this will foster technological experimentation and innovation, particularly with higher data rates, and facilitate the construction of a nationwide packet data backbone network. The Com-

mission expects that this action will relieve congestion in the 222-225 MHz band in certain geographic areas. The Commission said the amateurs' ability to perform interference analysis, the directional nature of the proposed services, and the secondary status of this proposed allocation should adequately protect all primary and existing secondary operations in and adjacent to the 219-220 MHz band. The Commission invites comment on these assessments and proposals.

## **Changes In Message Forwarding System Proposed**

The Commission proposed establishing a compliance policy for amateur stations participating in automatic message forwarding systems to hold the licensee of the station originating a message and the licensee of the first forwarding station primarily accountable for violative communications.

Under this approach, licensees of stations that only retransmit messages within a high speed message forwarding system would not be held accountable for communications they forward or their stations retransmit unwittingly.

Under the current rules each amateur licensee is fully responsible for assuring that the contents of every transmission from his or her station complies with the rules. This requirement was not a burden when licensees sent each message manually. With the availability of digital technology, however, some licensees have tied their stations together into high volume, high speed message forwarding systems. The stations are configured so that each message is instantly retransmitted to its destination through a series of stations.

Because message screening is difficult with these automatic systems and because screening at each station in these systems diminishes the advantages of high speed, the Commission proposed holding accountable only the licensee of the originating station and the licensee of the first station in a high speed message forwarding system.

## **New Experimentals**

The Commission, by its Office of Engineering and Technology, Frequency Liaison Branch granted the following experimental applications:

KM2XOJ, State of Alaska, new experimental to operate on frequencies 151.00-151.990 for wildlife tracking using telemetry. MO: Region II, AK.

KM2XOK, State of Alaska, new experimental to operate on frequencies 151.00-151.990 for wildlife tracking using telemetry. MO: Region III, AK.

KO2XAH, Motorola, Inc., new experimental to operate on frequencies in 18820-18920 MHz and 19160-19260

MHz for development and testing of pre-production and production of Wireless-In-Building Network (WIN) system and for Beta testing FX&MO: Conus; Alaska; Hawaii.

LO2XAM, AT&T Bell Laboratories, new experimental to operate on frequencies 5725-5850 MHz for development of electronic shelf labels. FX&MO: Chicago, IL.

KO2XAQ, AT&T Bell Laboratories, new experimental to operate on frequencies 5725-5850 MHz for development of electronic shelf labels. FX&MO: Holmdel, NJ.

KM2XPF, Capital Cities/ABC, Inc., new experimental to operate on frequencies 1636.5-1645 MHz for use of TCS-9000 INMARSAT terminal for news gathering. MO: Continental U.S.

KM2XPV, MCQ Associates, Inc., new experimental to operate on frequencies 1626.5-1646.5 MHz for use of INMARSAT Standard-C equipment. MO: Continental U.S.

KM2XPO, Bechtel, Corp., new experimental to operate on frequencies 1636.5-1645.0 MHz for use of INMARSAT system to provide emergency communication in the event of a natural or manmade disaster. MO: Continental U.S.

KM2XQM, COMSAT Land Mobile Services, new experimental to operate on frequency 1639.250 MHz for use of INMARSAT system. MO: Continental U.S.

KM2XQD, Scientific-Atlantic, Inc., new experimental to operate on frequencies 1626.5-1660.5 MHz for use of an INMARSAT Standard-M communications terminal used to assist in research and development program of new uses or applications for terminals.

KM2XQA, State of Alaska, new experimental to operate on frequencies 1635.5-1645.0 MHz for emergency communications in remote areas. MO: Within State of Alaska.

KM2XPQ, International Organization For Migration, new experimental to operate on frequencies 1636.5-1645.0 MHz for use of INMARSAT for communication in areas where no other means of communications are available. MO: Continental U.S.

KM2XOM, AI International, new experimental to operate on frequencies 1636.5-1645.0 MHz for use of an INMARSAT system and for demonstration purposes. MO: Within State of New York. KM2M2XPS, Marconi Communications, Inc., new experimental to operate on frequencies 1636.5-1645 MHz and 1535-1543 MHz for technical demonstrations via INMARSAT system. MO: Continental U.S.

KM2XRH, Able Communications Company, Inc., new experimental to operate on frequencies 1636.5-1654 MHz for demonstration of INMARSAT terminal to prospective customers. FX: Pearland, TX.

KM2XRD, Adroit Systems, Inc., new

experimental to operate on frequencies 15355-16450 MHz to fulfill U.S. Government contract (USAF).

KM2XQV, Union Oil Company Of California, new experimental to operate on frequencies 1636.5-1645.0 MHz and 1535.0-1543.4 MHz to provide emergency communication when no other means of communications are available. MO: Continental U.S.

KM2XQS, U.S. Newswire, new experimental to operate on frequencies 1626.5-1645.5 MHz and 1530-1545 MHz for use of INMARSAT-C terminal for mobile communications for American news media where conventional communication methods are unavailable. MO: Overseas; U.S.; and Wash., DC.

KM2XRC, Victory Marine, Inc., new experimental to operate on frequencies in the 1600 MHz range for INMARSAT earth station to allow communication with vessels at sea. FX: Seattle, WA.

KM2XPW, Trimble Navigation, Ltd., new experimental to operate on frequencies 1626.5-1646.5 MHz for marketing, testing, and demonstration of INMARSAT-C equipment. FX&MO: Sunnyvale, CA.

KM2XRJ, Alaska Clean Seas, new experimental to operate on frequencies 1636.5-1645.0 MHz for use of INMARSAT system to provide emergency communication in the event of an oil spill. MO: Within State of Alaska.

KM2XRK, BP Exploration, new experimental to operate on frequencies 1636.5-1654 MHz and 1535.0-1545.5 MHz for use of an INMARSAT system for emergency communication in the event of an oil spill or other types of disasters. MO: Continental U.S.

KM2XRL, NAV COM, Inc., new experimental to operate on frequencies 1635.0-1645.0 MHz and 1535.0-1545.5 MHz for use of an INMARSAT system for demonstrations and factory testing. MO: Continental U.S.

## **FCC Upholds Action Denying Proposed Amendment For 800 MHz SMR**

The Commission denied a Petition for Reconsideration submitted by the National Association of Business and Educational Radio, Inc. (NABER), thus, upholding the Private Radio Bureau's (PRB) action. PRB denied NABER's request to amend rules to specify that channels only be recovered from a licensee in the 800 MHz Specialized Mobile Radio (SMR) service for failure to load its system to 70 mobiles per channel if the waiting list for that SMR system's area includes at least one licensee applying for channels to expand an existing SMR system.

The Private Radio Bureau dismissed NABER's petition because NABER failed to justify its conclusion that there will be a



large, unwarranted surge in demand for SMR channels after the Commission eliminates the current loading requirements. The Bureau found, in fact, that NABER's conclusion is contrary to the Commission's finding that the SMR service has matured sufficiently to justify elimination of the channel recovery program, thereby allowing market forces to dictate the use of SMR channels.

NABER contended that recent developments confirmed its belief that speculative applications would be filed in areas where the demand for service does not justify the number of applications filed and that this trend will worsen in the future. Accordingly, NABER requested reconsideration of the Bureau's dismissal of the NABER petition and adoption of rules previously requested.

The Commission found the arguments presented by NABER are insufficient to justify reconsideration of the Bureau's dismissal of NABER's Petition for Rule Making. Although NABER has based its Petition for Reconsideration on circumstances that occurred after NABER filed its Petition For Rulemaking, the Commission found that these circumstances have not significantly altered the FCC's perception of the public interest.

Therefore, the Commission found that a rule making is not warranted due to the speculative nature of NABER's arguments. The FCC's current constructing and oper-

ation requirements, furthermore, provide the means for deterring speculators and for recovering any channels that are not used.

### **Propose Amending Rules Governing The Private Radio Services**

The Commission proposed to either relax or eliminate certain rules that impose an unnecessary regulatory burden.

First, the Commission has proposed to modify the rules to provide a 10 year license term for ship and aircraft station licenses. Currently, FCC rules provide that licenses for stations in the maritime and aviation services will normally be issued for a term of five years from the date of original issuance, major modification or renewal. The Communications Act, however, authorizes a 10-year term for such licenses. The Commission stated that no purpose is served by restricting ship and aircraft station licenses to a five year term and extending the license term would save the public approximately \$2,900,000 per year.

Second, Section 94.85 of the Commission's rules requires that licenses in the Private Operational Fixed Microwave Service perform specified measurements to ensure that their transmitters are maintained within the frequency tolerances required by the rule. However, the records specified in the

rule are not currently used by the Commission. Licensees must comply with the Commission's frequency tolerance rules at all times, thus a one-time measurements serves little purpose and there appears to be no need for a rule that requires licensees to follow a predesignated set of steps to prove compliance. Consequently, the Commission proposed eliminating the procedures outlined in Section 94.85.

Finally, Sections 94.113(a), (b), (d), (e), (f) and (g) of the rules require that licensees in the Private Operational Fixed Microwave Service maintain numerous records on station maintenance, including transmitter measurements and antenna inspections. Because licensees are required to maintain their systems in conformance with the FCC's rules, it is unnecessary to require specifically that they retain maintenance records. Therefore, the Commission proposed eliminating the unnecessary and burdensome obligations imposed by the rules.

### **FCC Adds San Francisco Port Area To Coast Guard Vessel Traffic Service Systems.**

In response to a request from the United States Coast Guard, the Commission changed Part 80 of its rules to add the San Francisco, CA, port area to the Coast



## DSP From JPS



### The NRF-7

The new NRF-7 is a medium priced DSP product which provides great flexibility in audio processing. Modes available include atmospheric (white) noise reduction through adaptive peaking; spectral multi-tone notch filtering; notch & peak combined; wide (2400 Hz) and narrow (1800 Hz) SSB filters, with and without spectral notch; wide (500 Hz) and narrow (250 Hz) CW filters with selectable center frequency; and a 500 Hz wide



DATA filter centered at 2200 Hz. Since these filters all operate in real time, they can be used for Break-in CW or AMTOR. Note: noise reduction by adaptive filtering reduces noise by dynamically reducing the bandwidth and is not effective against impulse-type noise. Only the NIR-10 uses spectral subtraction to eliminate impulse noises as well as atmospheric noise, while retaining the full audio bandwidth.

**Only: \$249.95**

The NIR-10, the standard in DSP Noise Reduction, still only \$349.95.

For eliminating carriers & other tones, the NF-60, still only \$149.95.



**JPS Communications, Inc.**  
P.O. Box 97757 Raleigh, NC 27624

TOLL FREE ORDER LINE 1-800-533-3819  
Technical Info 1-919-790-1048 FAX 1-919-790-1456

Guard designated radio protection areas for mandatory Vessel Traffic Services (VTS), and to establish marine VHF channel 14 (156.700 MHz) as the VTS frequency for the San Francisco port area.

A VTS system is used as an advisory service to coordinate vessel movement and prevent collisions in large, busy port areas. Vessels report information related to position, course speed, and conditions affecting their ability to navigate to the Coast Guard, which then tracks the movement of these vessels. VTS systems use VHF marine radiotelephone equipment to exchange voice communications on channels dedicated to VTS operations in Coast Guard designated VTS areas.

As a result of the Oil Pollution Act of 1990, the Coast Guard has initiated a rule-making proceeding to require certain vessels to participate in a VTS system in the port of San Francisco. The San Francisco

VTS system is designed to protect the marine environment by preventing vessel collisions and groundings. By designating San Francisco as a radio protection area for VTS communications, this Commission action will allow the Coast Guard to manage vessel traffic in that area more efficiently.

Additionally, the Commission designated marine VHF channel 14 exclusively for VTS operations with the specified geographic area. This channel is already allotted for VTS communications in other ports. The Commission will permit private coast stations currently authorized to operate on channel 14 within the VTS area to continue operation until the end of their current license terms.

Further, it was brought to the Commission's attention that currently its rules do not appear to authorize ship-to-ship Narrow Band Direct Printing (NB-DP) communications. The Commission stated that

this omission in Part 80 of the rules was inadvertent and amended Part 80.361 of the rules to clarify that ship-to-ship NB-DP is authorized.

Finally, with respect to Part 80 the Coast Guard asked the Commission to clarify the Channel 16 (156.800 MHz) watch requirement contained in Part 80. The Coast Guard noted that certain vessels required by Coast Guard regulation to carry radio equipment, such as fishing vessels, should be required to monitor channel 16 while the vessel is underway. Commission rules requires all compulsory VHF ship stations to maintain a watch on channel 16 during its hours of service. The Coast Guard believes that this requirement would be clearer if it were amended to read that compulsory vessels must maintain a watch "while underway." The Commission agreed and clarified the watch requirements contain in Section 80.148.

## Co-Channel Protection Criteria For Private Land Mobile Stations Operating Above 800 MHz

The FCC proposed revising the interference protection criteria and distance separations for co-channel private land mobile stations operating above 800 MHz.

Specifically, the Commission proposed eliminating the current disparity between the rules governing co-channel interference protection for Specialized Mobile Radio (SMR) and non-SMR systems. The Commission said that having the same protection criteria for all Part 90 systems operating above 800 MHz will be simpler and will reduce the burden upon applicants and the FCC.

This proceeding was initiated by the National Association of Business and Educational Radio, Inc. (NABER). Because SMR and non-SMR systems above 800 MHz are becoming technically and operationally similar, NABER requested that the same interference protection criteria apply to all 800/900 MHz systems operating under Part 90 of the rules.

The Commission agreed and noted that there is a narrowing of differences in the technical and operating parameters of these systems. The Commission concluded therefore, that having separate rules governing separation distances for SMR and non-SMR systems is no longer appropriate.

Accordingly, the FCC proposed a number of technical changes that include: 1) establishing a 40/22 dBu protection ratio for all co-channel stations operating above 800 MHz; and, 2) using a Table to determine co-channel station separations. The Commission emphasized that until this proceeding is terminated, applicants for 800/900 MHz systems will not be accepted unless they meet the co-channel separation criteria specified in 47 C.F.R. Section 90.621 (b).



### SCANNER REMOTES

Imagine... Complete control of your scanner in the palm of your hands. Control your scanner from across the room. Great for car use. The WR100 is designed to control the PRO-2006, but could be adapted to other models. Plans-\$10.00, Parts & Plans-\$40.00. Some assembled remotes will be sold.

Send SASE for information

**30ECKER ELECTRONICS**  
1653 Parkside Trail Lewisville, TX 75067

CIRCLE 53 ON READER SERVICE CARD

### CB RADIO OWNERS!

We specialize in a wide variety of technical information, parts and services for CB radios. 10-Meter and FM conversion kits, repair books, plans, high-performance accessories. Thousands of satisfied customers since 1976! Catalog \$2.

**CBC INTERNATIONAL**  
P.O. BOX 31500PC, PHOENIX, AZ 85046

## 1-800-666-0908

### New Equipment Orders & Prices Only, Please

#### Shortwave Radios

Sony® • All Popular Models Including The ICF2010, SW55, And The New SW77 • Philips DC777 AM/FM/CASS/Shortwave Car Radio • Sangean • ICOM • JRC • Panasonic • Yaesu, New FRG-100 • And the Superb

**Drake R8** 

#### Grundig Satellit 500

 **Call For Special Pricing** 

#### Grundig Satellit 700

#### Scanning Radios

Featuring AOR Models AR1000XLT and AR3000A • ICOM R1, R100, and R7100 • Uniden Bearcat - All Models

#### Amateur Radio Equipment

Factory Authorized Dealer For:

**ALINCO**  **STANDARD** **KENWOOD**  
**COMET** **YAESU** **MFJ**  
**DIAMOND**  **ICOM**  **CUSHCRAFT**

Accessories, etc.

• Call For Our Low Discount Prices •  
For info and tech help call (203) 666-6227  
Out-of-State Sales Call 1-800-666-0908  
Conn. Sales Call (203) 667-9479

## LENTINI COMMUNICATIONS, INC.

21 Garfield St. Newington, CT 06111  
C.O.D.'s OK - SAME DAY SHIPPING

CIRCLE 66 ON READER SERVICE CARD

### SE SIGNAL ENGINEERING'S High Performance CB Antennas

**SUPERHAWK**  
\$114.95

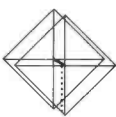

**Goldenrod 45 Mobile Antenna**

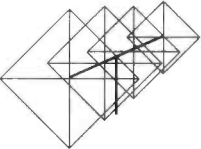

**SPYDER A**  
\$35.95



**WHITE LIGHTNING**  
\$199.95

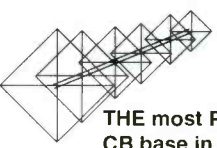

**LIGHTNING 6**  
\$359.95

**THE most POWERFUL CB base in the world today!**

ALL SE PATENTED rotary beams are true quads and OUTPERFORM their counter parts (quad/yagi types). SE's patented SFS matching system makes SE QUADS the most technologically advanced antennas in the world today.  
If your dealer doesn't have SIGNAL ENGINEERING, write or call for full specs. DEALER inquiries invited.

## SIGNAL ENGINEERING

2624 Fayette Drive, Mountain View, CA 94040  
(415) 948-3833



## INTERESTING THOUGHTS AND IDEAS FOR ENJOYING THE HOBBY

### An Idea To Get Your Blood Boiling

This month I'm going to throw out an idea that I think is really neat. Odds are that a healthy percentage of you will hate it, but hopefully enough of you will find it intriguing enough not to dismiss it out of hand, and will instead seriously consider the possible benefits and problems that could result from it.

#### Long Overdue—An Amateur Broadcasting Service

I love Ed Teach's pirate column each month in *POP'COMM*, and I look forward to the latest pirate reports in "The ACE," the bulletin of the Association of Clandestine Radio Enthusiasts (for a sample bulletin, send \$2 to PO Box 11201, Shawnee Mission, KS 66207-0201). The number of pirate stations continues to grow despite FCC enforcement efforts, leading me to a brainstorm that's probably going to provoke a strong reaction in some readers: maybe it's time for some sort of private non commercial broadcasting service structured somewhat along the lines of CB or ham radio.

Those of you who have been involved in hobby communications for a long time (like that guy named Kneitel) remember the CB radio service as it existed in the early 1960's. Back then, the FCC maintained that CB was intended as a sort of land mobile service for individuals and small businesses to use primarily for intrastation communications—a husband using the CB set in his car to talk to his wife back at home, for example.

Communications between stations of different licensees was supposed to be a rare event, and restricted to emergencies, requests for assistance, or for such purposes as radioing ahead to a motel to make room reservations. But too many CB'ers found it was fun to talk to other CB'ers on the air and ignored the FCC's CB rules (including some very restrictive ones imposed in the mid-1960's) in large and growing numbers. The FCC tried fining some stations big, and even threatened a test on FCC rules to get a CB license. But by the mid-1970's, the FCC was overwhelmed by the flood of CB license applications and rules violations, and as a result the FCC finally came to its senses. It legalized the sort of hobby communications people were doing anyway and did away with licensing altogether. The FCC got rid



# W S K Y

*MIKE RICHARDS—Wild Irish Rose-D.J.  
MIKE MICHAELS—Janitor in a Drummer  
STEPHANIE WELLS—The Voiceless Wonder  
DOUG BARLEY—Faithful Engineer  
TALL PAUL WESTON—Visiting professor of radio extraordinaire*

---

**E Q U I P M E N T P R O F I L E**

**Studio**    2 GLI-3880 Mixers, 1 GLI-1000 Meter Head, Radio Shack 33-1080 electret mic, Electro Voice 636 Slimaire, Realistic Tape Control Center, Realistic MC-1000 monitor speakers, Technics SL B101 manual belt-drive turntables, Teac CX-310 Tape Deck, Pioneer CTF 500 Tape Deck, Pioneer Rcvr-Amp SA-580, Realistic TR3000 (Teac Equiv.) Reel to Reel, Technics SL-XP6 Portable CD Player, Teac PD-700M Multi-player CD, Realistic Stereo Mixer for S.T.L. Interface, and plenty of patch cables!

**S.T.L.**    Audio is fed into an ICOM 735 and transmitted over an 11-Meter Free-band freq. with a Hustler G 2537 Antenna and a quality NEJ 949D Tuner. Doug Barley receives the signal on FM with a Bearcat BC800 XLF Scanner and Solarcon 99 Antenna. Audio is sent into a Realistic Mixer equalized by a Realistic EQ with Realistic Reverb, then added. Other audio equipment includes: Teac PD-80 CD player and a Pioneer CTS200 Tape Deck. Audio is then sent to the transmitter.

**Ant:**    Transmitter is a Yaesu 757-GX II Transceiver. Xmtr is cut back to 15 watts and sent to a Heathkit Warrior Amplifier. Amp. uses 4-811's in grounded grid. This results in Approx. 200-220 watts, clean, American modulation. RF is then sent to a set of Heath HM-102 watt meters and a Dentron MT 2000A Antenna Tuner. Antenna is a Half-Wave Dipole, up about 40 feet...cut to 7413 Mhz.

**Intent:**    You are probably asking why? Why are we taking the risk of monetary forfeiture to broadcast...Because we have a mission from God. (Sound familiar?) Seriously folks, we have a mission and that mission is to fill the void created by the current group of commercial broadcasters. It seems that no one ever touches upon the lesser known classics; when we say classics, we mean that a classic doesn't have to be gold. It could have had a reasonable amount of high-profile air play in local markets or perhaps been a sleeper-hit, of sorts.

**WhiSSKeY RADIO!**  
THE STATION THAT JACK BUILT

Stations such as WSKY show the demand for a "people's broadcasting" service.

of a major headache and CB'ers were able to enjoy what they had been doing all along—talking to each other as a hobby—without the threat of arbitrary and capricious fines and other enforcement actions. And when the FCC finally caved in, the world didn't come to an end, as some pre-

dicted. Things continued as they always had, and CB'ers and the FCC were both a lot happier.

So what does the history of CB radio have to do with pirate broadcasting? Simple—history is repeating itself. It's clear that there are growing numbers of people

# POP'COMM's

## World Band Tuning Tips

### July—1993

Freq.	Station/Country	UTC	Notes	Freq.	Station/Country	UTC	Notes
2390	La Voz de Atitlan, Guatemala	0230	SS	6050	R. Canada Int'l	0600	
2967v	R. Runacunapac, Ecuador	1030	SS	6060	Radio Havana Cuba	0600	
3200	R. 9 de Abril, Bolivia	0100	SS	6070	R. Ukraine Int'l	0130	
3205	R. Ribeirao Preto, Brazil	0900	PP	6095	Radio Free Europe, Germany	0600	Lithuanian
3215	R. Oranje, South Africa	0300	EE/Afk	6105	R. Yucatan, Mexico	1200	irr., SS
3231	R. Madagasikara, Madagascar	0330	unid lang.	6120	R. Japan	1130	via Canada
3250	R. Luz y Vida, Honduras	0200		6130	CHNX, Canada	1000	
3260	R. Madang, Papua New Guinea	1100		6130	GBC, Ghana	0700	
3270	Namibian Bc Corporation	0300		6135	R. Santa Cruz, Bolivia	0900	SS
3275	R. So. Highlands, Papua New Guinea	1200		6135	Swiss Radio Int'l	0230	
3285	LV del Rio Tarqui, Ecuador	0900	SS	6145	HRTV, Croatia	0800	
3300	R. Cultural, Guatemala	0200		6155	Radio Austria Int'l	0830	
3316	SLBS, Sierra Leone	0600		6165	R. Netherlands, via Bonaire	0030	
3320	R. Orion, South Africa	0245		6170	La Voz de la Selva, Colombia	0300	SS
3330	CHU, Canada		time stn	6195	R. Metropolitana, Bolivia	1000	SS
3335	TWR, Swaziland	0300	PP	6205	HCJB, Ecuador	0800	
3360	La Voz de Nahuala, Guatemala	0305	close, SS	6219	Radio Bosnia-Hercegovina	0200	irregular
3370	R. Tezulutlan, Guatemala	0130	local langs	6220	R. Sofia, Bulgaria	2130	Bulg.
3384	Icelandic State Broadcasting Service	0330	Icelandic	6250	R. Nacional, Equatorial Guinea	0500	SS
3395	Channel Africa, S. Africa	0400		6270v	R. Patria Libre, Colombian clandestine	0030	SS
3980	VOA via Germany	0600		6305	La Voz del CID (anti-Castro)	0800	SS
4000	R. Cameroon, Bafoussam	0430	FF	6560v	Iraqi Radio	0330	AA
4040	R. Yerevan, Armenia	0300	Arm.	6900	Voice of Meterology, Turkey	0530	TT
4331	R. Horizonte, Peru	1100	SS	7100	Voz Res. Galo Negro, clan	2300	PP
4460	CPBS-1, China	1300	CC	7105	REE, Spain	0430	SS
4600	R. Villamontes, Bolivia	1000	SS	7115	V of Pujiang, China	1130	CC
4635	R. Dushambe, Tadzhikistan	0200	local lang.	7140	R. Italia Int'l	0700	
4705	Estacion Laser, Peru	0900	SS	7150	R. Vilnius, Lithuania	0000	
4760	Yunan PBS, China	1130	CC	7170	ORTS, Senegal	0600	s/on, FF
4760	R. Frontera, Venezuela	0130	SS	7175	RAI, Sicily	0700	Ital
4765	RTVC, Congo	0355	s/on, FF	7180	R. Ukraine Int'l	0100	
4770	R. Nigeria, Kaduna	0500		7195	R. Sofia, Bulgaria	0700	
4770	R. Centinela del Sur, Ecuador	1030	SS	7215	R. Denmark via R. Norway	0530	DD
4775	Radio Exterior de Espana, Spain	0530	SS	7235	Deutsche Welle, Germany	0400	AA, via Malta
4800	R. Lesotho	0330		7250	Vatican Radio	0600	//6245
4810	R. Orion, S. Africa	0200		7255	V of Nigeria	0500	
4833	R. Buenaventura, Colombia	0100	SS	7260	R. Netherlands via Russia	0930	
4845	RTM Malaysia	1200	Malay	7265	VOA Relay, Botswana	0300	sign on
4850	R. Luz y Vida, Ecuador	0300	SS	7275	ELBC, Liberia	0700	
4870	ORTB, Benin	0530	FF	7285	RT Malienne, Mali	0700	FF
4875	V of Jinling, China	1100	CC	7315	BBC via Uzbekistan	0100	
4875	La Cruz del Sur, Bolivia	1030	SS	7345	R. Prague (& Slovensko R. at 0130)	0100	
4885	R. Clube do Para, Brazil	0100	PP	7365	KNLS, Alaska	0800	sign on
4890	R. France Int'l, Gabon relay	0400	FF	7370	R. Flanders Int'l, Belgium	0030	
4895	LV del Rio Aruca, Colombia	0200	SS	7385	R. Neg-Maaron, via RFPI, Costa Rica	0230	
4910	Zambia National Broadcasting Svc	0300		7445	V of Asia, Taiwan	1400	CC
4915	R. Cora, Peru	1030	SS	7465	Reshet Bet HS, Israel	0100	Hebrew
4915	GBC, Ghana	0600		7510	KTBN, Utah	0400	
4920	R. Quito, Ecuador	0300	SS	7550	R. Korea, S. Korea	2230	
4935	R. Capixaba, Brazil	0300	PP	9170	R. Omdurman, Sudan	0255	sign on, AA
4950	R. Bahai, Ecuador	1030	SS	9275	Icelandic State BC	2300	Icelandic
4950	Voice of Jinling, China	1200	CC	9345	R. Pyongyang, N. Korea	1300	
4960	R. Cima Cien, Dominican Republic	0100	SS	9435	Kol Israel	0500	
4976	Ondas del Orteguez, Colombia	1000	SS	9445	Voice of Turkey	2330	TT
4980	Ecos del Torbes, Venezuela	0200	SS	9455	KHBI, No. Marianas	1000	
4985	R. Brazil Central	0100	PP	9475	R. Cairo, Egypt	0200	
4990	R. Nigeria, Lagos	2230		9490	R. Nadezhda, Russia	1530	RR
5004	R. Nacional, Eq. Guinea	2130	SS	9505	R. Tacna, Peru	1030	SS
5025	R. Journal Transamazonica, Brazil	0900	PP	9510	R. New Zealand	0930	
5025	R. Rebelde, Cuba	0200	SS	9510	R. Australia	1100	
5030	R. Continente, Venezuela	0330	SS	9535	Swiss Radio Int'l	0700	
5035	Rdf. Centrafricaine, Cent Af Rep.	0430	FF	9540	R. Rajo (Hope), Somalia	1200	close
5047	RTV Togolaise	0524	s/on, FF	9545	Solomon Is. Bc Corp.	0700	
5055	RFO, French Guiana	0700	FF	9555	R. Veritas Asia, Philippines	1430	
5075	Caracol Bogota, Colombia	0400	SS	9560	Radio Finland	0230	
5097	R. Eco, Peru	0200	SS	9560	R. Jordan	1600	
5800	R. Nueva Cajamarca, Peru	1000	SS	9565	R. Universo, Brazil	0900	PP
5882	Vatican Radio	0030	Italian	9570	R. Portugal	0230	
5900	R. Vlaanderen Int'l, Belgium	0600	(ex-BRT)	9575	Radio Medi Un, Morocco	0730	FF
5945	VOA via Russia	1400	CC	9575	Voice of America	0245	s/on, Somali
5950	V of Free China via WYFR	0230		9580	R. Tirana, Albania	0230	
5960	Swiss R. Int'l	0330		9590	R. Georgia, Georgia	0430	
5975	R. Macarena, Colombia	1100	SS	9600	HCJB, Ecuador	0500	
6005	RIAS, Germany	0700	GG	9600	R. UNAM, Mexico	1300	SS
6020	Radio Netherlands	0100		9605	UAE Radio, Abu Dhabi	2200	s/on
6030	CFVP, Canada	1100		9615	R. Cultura, Brazil	0700	PP



Freq.	Station/Country	UTC	Notes	Freq.	Station/Country	UTC	Notes
9625	CBC Northern Service, Canada	0300		13630	RFPI, Costa Rica	2300	
9640	VOIRI, Iran	1500	sign on, Farsi	13635	Swiss Radio Int'l	2130	
9645	Faro del Caribe, Costa Rica	0400	SS	13650	R. Pyongyang, N. Korea	0000	
9665	Radio Marumbi, Brazil	2300	PP	13655	R. Flanders Int'l, Belgium	2300	Dutch
9675	Channel Africa	0300		13660	R. Havana Cuba (USB)	0200	USB, EE
9695	Channel Africa, S. Africa	0500		13675	UAE Radio, Dubai	1630	
9695	R. Sweden	0200		13685	Swiss R. Int'l	0700	
9700	R. New Zealand	1030		13715	R. Prague, Czech Rep.	0400	
9705	R. Nacional, Brazil	2300	PP	13750	Kol Israel	1500	Heb.
9715	RFI via Fr. Guiana	0130	FF	13755	R. Australia	1200	
9718	SLBC, Sri Lanka	0100		13785	R. Pyongyang, N. Korea	1500	
9730	Channel Africa, S. Africa	0159	s/on	15010	V of Vietnam	1230	
9735	R. Nacional, Paraguay	2300	SS	15020	All India Radio	1400	local langs.
9740	R. Canada Int'l	0630		15084	VOIRI, Iran	0430	Farsi
9746	R. Bahrain	2000	AA, QRM-HCJB	15090	Vatican Radio	2245	s/on
9750	R. Korea, So. Korea	1200		15100	FEBC, Philippines	1400	EE, others
9750	R. Canada Int'l	0530		15110	REE, Spain, via Costa Rica	1900	
9760	R. Tirana, Albania	0130	Albanian	15120	R. New Zealand Int'l	0530	
9765	V of Mediterranean, Malta	0600		15130	R. Pyongyang, N. Korea	0000	
9770	China R. Int'l, via Mali	0000		15140	R. Veritas Asia, Philippines	1500	Filipino
9805	R. France Int'l	1230		15170v	Radio Tahiti	0500	FF/TT
9815	Radio Havana Cuba	0200	SSB	15185	R. Finland Int'l	2300	
9830	KHBN, Palau	1300		15200v	R. Bangladesh	1230	EE
9835	R. Budapest, Hungary	0200		15220	Channel Africa, S. Africa	0600	(ex R. RSA)
9840	R. Kuwait	2100	AA	15240	R. Australia	0900	
9845	FEBC, Philippines	1600		15250	Iraqi Radio	1400	EE
9860	R. Netherlands via Russia	1100		15265	Radiobras, Brazil	1800	
9880	R. Galaxy, Russia	2300	RR	15270	Deutsche Welle via Rwanda	2330	GG
9885	Swiss Radio Int'l	0200		15295	WINB, Pennsylvania	1830	
9942	Voz del CID, anti-Castro	2300	SS	15325	R. Japan via Fr. Guiana	0300	
9977	R. Pyongyang, N. Korea	1100	s/on	15335	R. Romania Int'l	1430	
10059	V of Vietnam	1500	VV	15340	R. Japan, via Gabon	2000	RR
11402	Icelandic State Bcstng	2300	Icelandic	15345	RAE, Argentina	2130	
11550	RTT Tunisia	1800	AA	15345	RTM, Morocco	1400	Berber
11587	Kol Israel	2245		15345	RAE, Argentina	1300	SS
11603	Kol Israel	2230		15355	R. Japan via Gabon	1500	
11620	All India Radio	2000		15360	Deutsche Welle, Germany	2100	
11650	China Radio Int'l (R. Beijing)	1500	RR	15400	UAE Radio, Dubai	0345	
11685	BSKSA, Saudi Arabia	2130	AA	15415	Libyan Jamahiriyia Broadcasting	1500	AA
11690	FEBC, Philippines	1100		15420	BBC via South Africa	1745	sign on
11695	Radio France Int'l	0530	FF	15425	SLBC, Sri Lanka	1330	
11700	R. Art, Russia	1600	RR	15445	SLBC, Sri Lanka	2330	
11705	R. Sweden	2330		15465	R. Tashkent, Uzbekistan	1200	
11710	RAE, Argentina	0100		15475	Africa Number One, Gabon	2100	FF
11715	R. Korea, S. Korea	1030	via Canada	15505	Swiss Radio Int'l	1500	
11720	R. Sofia, Bulgaria	0400		15505	R. Kuwait	2245	AA
11725	R. Korea, S. Korea	1000	SS	15555	R. Pakistan	1620	slow EE
11735	R. Monte Carlo, Uruguay	2300	SS	15570	R. Ukraine Int'l	1500	
11740	R. Portugal	1900		15575	BBC via Cyprus	1300	
11745	Channel Africa, S. Africa	0200		15615	Rashuth Hashidur service, Israel	1700	Hebrew
11755	R. Finland Int'l	0130		15635	V of Greece	1230	
11765	R. Sofia, Bulgaria	2300		15725	KCBI, Texas	2200	
11780	R. Nacional Amazonia, Brazil	2345	PP	16000	VNG, Australia (time stn)	0800	
11790	VOIRI, Iran	1200	Urdu/EE	17440	R. Kiribati	0600	
11795	UAE Radio, Dubai	1600		17490	HCJB, Ecuador	1900	USB
11795	R. Norway	2300		17535	HCJB, Ecuador	0000	USB
11800	RAI, Italy	0100		17550	R. Flanders Int'l, Belgium	1400	
11800	Channel Africa, South Africa	0430		17595	R. Cairo, Egypt	1200	
11805	R. Globo, Brazil	0830	PP	17605	R. Vilnius, Lithuania	0000	
11820	R. Sweden	0100		17650	R. France Int'l	1400	
11825	R. Tirana, Albania	2200		17670	R. Cairo, Egypt	1800	AA
11830	Voice of Russia	1230	RR	17690	R. Ukraine Int'l	0100	
11835	R. El Espectador, Uruguay	0100	SS	17690	R. Yerevan, Armenia	0345	
11840	R. Tirana, Albania	0230	s/on	17730	Vatican Radio	0628	s/on
11855	R. Canada Int'l	1330		17740	R. Yugoslavia	1200	
11860	R. Iraq Int'l	0400		17740	R. Sweden	1300	EE
11870	R. Yugoslavia	0040		17745	Radio Portugal	1330	PP
11880	R. Australia	1600		17745	R. Tashkent, Uzbekistan	1200	
11890	R. Exterior Espana, Spain	0630	SS	17750	Radio Nacional	1800	PP
11920	BSKSA, Saudi Arabia	1500	AA	17760	R. Filipinas, Philippines	0230	
11925	R. Bandeirantes, Brazil	0100	PP	17765	Deutsche Welle, Germany	1330	
11938	V of People of Cambodia	0030		17770	R. New Zealand Int'l	0445	
11940	R. Romania Int'l	1300		17815	RTV Morocaine	1700	
11955	R. Nacional, Angola	0600	PP	17860	R. Moscow	2330	
11960	RTV Maliene, Mali	0900	FF	17860	Qatar Bc Service	1300	AA
11965	V of the UAE	1800	AA	17870	R. Sweden	1500	
11970	R. Havana Cuba	0130		17875	R. Canada Int'l	2130	
11980	R. Ukraine Int'l	0230	Ukrainian	17880	R. Finland Int'l	1300	
11985	R. Prague, Czech Republic	0400		17900	R. Pakistan	1115	
11985	UAE Radio, Dubai	2100	AA	21490	Radio Austria Int'l	1430	
11995	R. Sweden	2200		21455	HCJB, Ecuador	1900	
12015	Radio France Int'l, via Gabon	1600		21460	R. Ukraine	1430	RR
12050	R. Cairo, Egypt	0300	AA	21505	BSKSA, Saudi Arabia	1600	AA
12060	R. Yerevan, Armenia	2230	FF	21605	R. Yugoslavia	1230	
12085	R. Damascus, Syria	2005		21625	Radio Sweden	1330	
13605	Radio Australia	2300		21675	R. Kuwait	1500	AA
13620	R. Kuwait	2000		25750	R. Australia	0800	
13615	R. Bangladesh	1300		25820	R. France Int'l	1430	F

who want to broadcast to other people, but just talk to them. Each year, more people are doing it and getting away with it. The FCC is losing control of the situation, and maybe it's time for the FCC to wise up and permit some form of broadcasting service to open to the public with minimal restrictions.

### Who Needs It—And Why?

There are a lot of good reasons for an amateur broadcasting service besides the FCC's inability to control current pirate broadcasters. Perhaps the biggest is the simple fact that the radio spectrum within the United States is supposedly the property of the people of the United States, yet the use of that spectrum is largely restricted to well-financed corporations or educational institutions. And those organizations often don't do too much that's creative or of service to local communities. For example, commercial broadcasters have been steadily moving toward satellite-fed music programming and network talk shows, resulting in a very real loss of programming diversity and innovation.

This restriction of broadcasting to commercial or education institutions shuts out significant segments of the population from the programming and information that might be of interest to them. Only a fraction of the religious, ethnic, and political

groups that make up American society have access to the airwaves, and existing commercial and educational broadcasters have so far convincingly failed to accommodate such segments of the population. In fact, the massive expansion of AM and FM broadcasting stations that took place in the 1980's only resulted in more stations carrying Larry King or some satellite music service, not in any real innovation in programming.

Since the radio spectrum in the United States supposedly belongs to the people, why don't average citizens have some portions of the airwaves available to them so they can broadcast their thoughts, opinions and programs to their fellow citizens? After all, you can stand on a street corner and proclaim your thoughts to passers-by, and I can tell you what's on my mind each month here in *POP'COMM*. What is so different—or dangerous—about someone doing the same thing via radio instead of by voice or print?

Think for a second about what amateur broadcasting could mean. Smaller towns and areas overlooked by big city stations could have stations devoted to news and events in their local communities. High schools might have their own stations, as might a variety of civic, social, and fraternal organizations. Different parts of cities might have their own local stations (New York City might have a real "Village

Voice"! ). And talk about free-spirited debate on major political and social issues!

I know some people will say this entire idea is impractical because some individuals will abuse any amateur broadcasting privileges. Such people are right—a certain percentage will indeed abuse any broadcasting privileges. But such abuse is the cost of any freedom, and I think the benefits of allowing citizens to broadcast will far outweigh any abuses. Why should access to an electronic means of disseminating news and opinions be restricted to a moneyed or educational elite.

### Where Should I Go?

Another objection might be that there is no room for such amateur broadcasting. While this is true for the AM and FM broadcasting bands, there are some large chunks of frequency space that could easily be reallocated to or shared with amateur broadcasting, particularly above 25 MHz. In fact, try tuning from 25 MHz to the beginning of the CB band at 26.965 MHz. Even during the daytime in the winter DX season, this is a largely unpopulated range filled mainly with bootleg two-way radio communications. There is an 11-meter international broadcasting band from 25.67 to 26.1 MHz, but this was seldom used by international broadcasters even during the peak of the last sunspot cycle. The rest of

# ICOM's IC-R9000 . . . . . . The Best Of Both Worlds

The pacesetter IC-R9000 truly reflects ICOM's long-term commitment to excellence. This single-cabinet receiver covers both local area VHF/UHF and worldwide MF/HF bands. It's a natural first choice for elaborate communications centers, professional service facilities and serious home setups alike. Test-tune ICOM's IC-R9000 and experience a totally new dimension in top-of-the-line receiver performance!

**Complete Communications Receiver.** Covers 100 KHz to 1999.8MHz, all modes, all frequencies! The general coverage IC-R9000 receiver uses 11 separate bandpass filters in the 100KHz to 30MHz range and precisely-tuned bandpass filters with low noise GaAsFETs in VHF and upper frequency bands. Exceptionally high sensitivity, intermod immunity and frequency stability in all ranges.

**Multi-Function Five Inch CRT.** Displays frequencies, modes, memory contents,

operator-entered notes and function menus. Features a subdisplay area for printed modes such as RTTY, SITOR and PACKET (external T.U. required).

**Spectrum Scope.** Indicates all signal activities within a +/-25, 50 or 100KHz range of your tuned frequency. It's ideal for spotting random signals that pass unnoticed with ordinary monitoring receivers.

**1000 Multi-Function Memories.** Store frequencies, modes, and tuning steps. Includes an editor for moving contents between memories, plus an on-screen notepad for all memory locations.

**Eight Scanning Modes.** Includes programmable limits, automatic frequency and time-mark storage of scanned signals, full, restricted or mode-selected memory scanning, priority channel watch, voice-sense scanning and scanning a selectable width around your tuned frequency. Absolutely the last word in full spectrum monitoring.

**Professional Quality Throughout.** The revolutionary IC-R9000 features IF Shift, IF Notch, a fully adjustable noise blanker, and more. The Direct Digital Synthesizer assures the widest dynamic range, lowest noise and rapid scanning. Designed for dependable long-term performance. Backed by a full one-year warranty at any one of ICOM's four North American Service Centers!

The ICOM logo features a stylized red 'O' above the letters 'ICOM' in a bold, red, sans-serif font.

**First in Communications**

ICOM America, Inc., 2380-116th Ave. N.E., Bellevue, WA 98004  
Customer Service Hotline (206) 454-7619  
3150 Premier Drive, Suite 126, Irving, TX 75063  
1777 Phoenix Parkway, Suite 201, Atlanta, GA 30349  
ICOM CANADA, A Division of ICOM America, Inc.,  
3071 - #5 Road, Unit 9, Richmond, B.C. V6X 2T4 Canada  
All stated specifications are subject to change without notice or obligation. All ICOM radios significantly exceed FCC regulations limiting spurious emissions. 9000489





# SCANNING VHF/UHF

BY CHUCK GYSI, N2DUP

## MONITORING THE 30 TO 900 MHz "ACTION" BANDS

**T**he favorite time of year for scanner hobbyists is here. You carry around your handheld scanner to amusement parks, downtowns and anywhere else the scanning may be exciting. It is a time of year when there is not only plenty of skip on VHF low band frequencies, but also plenty of inversion on VHF and UHF frequencies that allows you some nights or mornings to listen to communications up to hundreds of miles from your listening post. If strange stations start coming in on your scanner, it's a good chance that there is an inversion trapping those signals and ducting them all the way to your receiving location. Enjoy listening to those distant stations while you can; it won't last more than a few hours at best.

Ray Gromek of Ortonville, Michigan, says his employer uses walkie-talkies on 154.570 and 154.600 MHz. He wants to know what other companies use these special low-power channels. The two frequencies are used on a local basis with a maximum power output of 2 watts. They typically are used for on-site communications and security purposes. I'd love to be able to provide listings for these frequencies, but it would go on for pages. Even within your own area of the state, the listing might prove exhaustive.

It also should be noted that for every licensed user on these frequencies, there probably are as many unlicensed stations using these channels. Because most over-the-counter business-oriented walkie-talkies might include one of these two channels, there are plenty of buyers who never bother to license their units. In fact, there have been teen-agers who have used 154.600 in several areas of the country with excessive power (typically 25 watts or more) to chit-chat among each other. They often use cop-like talk and even have their own CTCSS tone to keep their receivers silent from legitimate users they are interfering with. Keep an ear on these two low-power channels because you never know who may show up on the channels.

Mitchell R. McElveen of New Zion, South Carolina, says he recently subscribed to *POP'COMM* and enjoys this column. He works for the Manning, S.C., Fire Department as a firefighter (engineer) and also is a volunteer for the Clarendon and Williamsburg County Fire Departments in South Carolina on the days he isn't working. Mitchell's listening equipment consists of a Uniden Bearcat BC140 scanner at home, a Uniden Bearcat 560XLT scanner in his truck, Motorola Minitor pagers for fire calls, a Motorola Radius GP300 walkie-talkie issued by the city, a Realistic Pro-27 two-channel receiver and a new Uniden

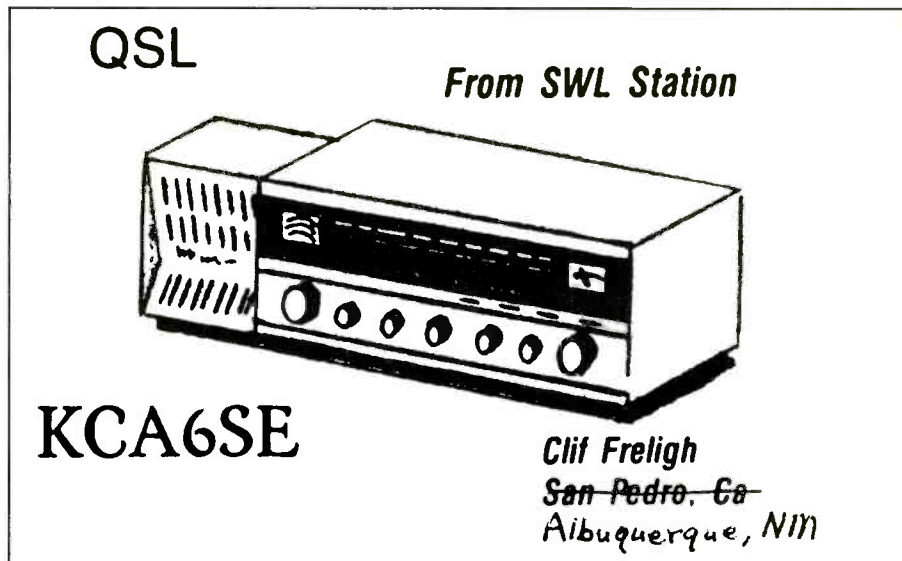

Station card of Clif, Registered Monitor, KCA6SE.

Bearcat 200XLT handheld scanner.

Mitchell asks why the range from 868.9875 to 894.0125 is eliminated from his Bearcat 200XLT scanner. He wants to know if these frequencies are in use, and if so, why they are eliminated from his scanner. He also wants to know whether this range can be restored to his receiver. First, the range from 869-894 MHz is used for the base side of cellular phone calls (the mobile side is 45 MHz lower and also is eliminated from your receiver - 823.9875 to 849.0125). This range can be restored to Bearcat 200XLT and the similar BC-205XLT scanners, but the Electronics Communications Privacy Act of 1986 prohibits persons from listening to cellular phone calls. You might be able to find a dealer who is willing to make the modification to your receiver. While some versions could be modified by simply snipping a diode, other versions require additional procedures to make the modification. There also are modification books available from many scanner dealers that detail how to make such modifications to your scanner.

Mitchell McElveen also sends along these frequencies for his area: 154.370, Clarendon County and Manning fire; 155.190, Clarendon County police; 154.325, Williamsburg County fire; 155.310, Williamsburg County police; 158.835, Manning city government; 154.340, Sumter County fire; 154.875, Sumter County police; 154.800, Sumter city police.

Paul Godshall of Perkasio, Pennsylvania, writes to say that he has heard that the police departments in eastern Mont-

gomery County have switched from VHF low band to UHF over the past few years and he would like a listing of the new frequencies. These towns are just outside of Philadelphia. Here are the new assignments: Abington Township, 460.025; Cheltenham Township, 460.100; Hatboro Borough, 500.9375; Horsham Township, 506.3125; Lower Moreland Township, 460.500; Plymouth Township, 453.875; Upper Dublin Township, 460.550; Upper Moreland Township, 460.050; and Whitpain Township, 453.675.

Hatboro's use of 500.9375 caused some trouble at first. It seems that there was a cab company in Philadelphia that had been using the frequency for a number of years in the business radio service. Well, their license accidentally lapsed and the frequency became available for assignment. Hatboro police received the frequency for their new UHF system and apparently no one listened to the frequency before setting up the system. Well, the police in Hatboro started using their new radios, but they were plagued with interference from the cab company. The police stopped using the frequency and went back to their old frequency of 39.08 in the interim. Instead of telling the cab company, which was a major firm, to get off the air, they worked with their supplier, the Federal Communications Commission—and each other—to remedy the situation. In fact, when the matter finally was resolved, the cab company had a new frequency. Hatboro police were using their new radios on 500.9375, and the owner of the cab com-





Todd Wiese of Fairfield, Ohio, relaxes in his listening post. His receivers include a Uniden Bearcat 800XLT scanner, a Midland tunable VHF/UHF receiver, a Regency 8-channel scanner, a DAK shortwave receiver and an Atari computer. Todd hopes to get on the ham bands, including packet, soon since he holds a ham license.

pany had nothing but glowing comments for Hatboro's police chief. And the Hatboro Police Department was presented with a new UHF walkie-talkie from the cab company as a token of its appreciation in cooperation. Too bad most radio conflicts aren't handled in this manner.

Bob Rossini of Tiltonsville, Ohio, says he's been listening to the Yorkville, Ohio, Police Department, which seems to operate a telephone system on one of its frequencies. 39.84. He wonders how it works. Apparently whenever someone calls the department on the phone, a ringing sound goes out over the frequency and then he can usually hear both sides of the conversation. Apparently, a police officer is answering the phone call from the patrol car. This means there is a phone patch unit at the department's base station radio that sends out the alert signal whenever the phone at headquarters rings. Then the patrol car answers the phone by transmitting on the frequency. Sometimes, Bob says that the phone rings over the air for two or three rings, but he isn't able to hear the conversation. That only means that someone probably is in the station and is answering the phone on the office phone. Because the radio is connected to the phone line, you'll hear it ring over the air, but because the call is being answered on the office phone and not over the radio, you won't hear the call over the air.

Bob listens with a Realistic Pro-2006 scanner and he is searching for other fre-

quencies used by Yorkville police. You may want to try 39.30, 39.52 and their dispatch frequency, 39.58, which is shared with the Jefferson County Sheriff and other departments throughout the county.

Brian Webb, editor of *VHF LOW BAND NOTES*, sent along a sample of his publication. The seven-page newsletter included recent VHF low band loggings and details of the intercepts. In addition, there was information on maximum usable frequency, which helps low band DX'ers figure when the 30-50 MHz band might be hot. In the back of the publication are full-page QSL letters received from various users of VHF low-band radio systems that were heard via skip. It's interesting to see what these QSL letters say and are valuable in terms of names and addresses for others who are also interested in getting QSL letters for hearing the same stations.

There was no subscription information in the copy of the newsletter received, and it wasn't indicated how often the newsletter is published. If you are interested in low-band skip, write to the editor, Brian Webb, at: 3329 Silver Spur Court, Thousand Oaks, Calif. 91360-1041.

John Basley of Hopewell, New Jersey, says that he is familiar with the itinerant business radio frequencies of 151.625, 464.500, 464.550, 469.500 and 469.550. These frequencies are used by businesses that move around from area to area a lot, and are an effort to minimize interference to normal business radio users on

their everyday frequencies. (It should be noted that 27.49, in the AM mode, and 35.04 also are itinerant business frequencies, however, these aren't used much.) John says that he has heard that there are similar itinerant frequencies used by for instance, construction crews and farms, however, he hasn't been able to find these frequencies. These frequencies, which are licensed under the special industrial radio service, are 43.04, 151.505, 158.400, 451.800 and 456.800 (mobile only). The 151.505 MHz channel probably is the most popular one of the bunch, with 158.400 and 451.800 also getting a fair amount of use. The 43.04 frequency is used in some rural areas where VHF low band works best. Stick these frequencies into your scanner and you may hear some heavy construction crews on a major project or a road-paving job. You never know who might be using these frequencies.

If you have a question relating to VHF or UHF frequencies, we'll try to answer them in this column. We also welcome your reception reports, frequency lists, photos of your listening posts or mobile installations, QSL letters, and photos of dispatch centers and antenna sites. Send your information to: Chuck Gysi, N2DUP, Scanning VHF/UHF, Popular Communications, 76 N. Broadway, Hicksville, N.Y. 11801-2909.

## The Toughest Little "GUNN" in Town!

3 + 3 STAR

UPS SHIPPABLE



Other Models & Sizes Available in 10 or 11 Meters



Call or send \$2.00 for Complete Catalog and Pricing of Antennas.



Route 1 - Box 32C, Hwy. 82  
Ethelsville, AL 35461  
(205) 658-2229  
FAX: (205) 658-2259  
Hours: 9 am - 5 pm (CST)  
Monday - Friday

DEALER INQUIRIES, PLEASE CALL

## DX, NEWS AND VIEWS OF AM AND FM BROADCASTING

**Switcheroo:** Boston/Framingham, Mass. station WVBF/105.7 dropped its soft-rock format. It turned into WCLB with a country music format and is now known as "The Country Club." This information submitted by Harvey Novack, Somerville, Mass.

**Surprise Welcoming:** The community of Bay Shore, N.Y. anxiously awaited the opening of WBSI/103.5 (B-103), its new (and only) broadcasting station. B-103 is female-owned, and the format is classic rock from the 1960's. After a few days of equipment tests, WBSI was ready to officially open and its full schedule.

Before this could happen, WBSI found itself in court at the behest of adult contemporary music format station WBLI/106.1, Medford, N.Y. The stations are about twenty miles from one another and can be heard by listeners in the same general area. WBLI complained that WBSI's call letters were too similar to the WBLI call letters. They claimed WBLI was their trademark. WBSI explained that their frequency and format was different than WBLI's, that their station was to be promoted as B-103, and the BSI in their call letters represented Bay Shore/Islip, which was their location.

Pending a later court hearing, the judge told WBSI to temporarily announce its call letters as "WBSI, not to be confused with WBLI." After two weeks of this, WBSI changed its call letters to WBZO. Some fans of the new station felt they should have put up more of a scrap and not caved in.

Are FCC-issued call letters actually trademarks? Hard to believe that this could be a valid point in court since call letters are subject to cancellation, revocation, and change by the FCC. If that should happen, what becomes of the so-called trademark?

Our appreciation to Harry Pernecone for letting us know about this.

**Down The Tubes:** An anonymous reader in San Jose, Calif., brings up the point of TV stations that sign off, but then remain on the air for the rest of the night running a test pattern. Once in a while it would seem necessary to tune things up. However, doing it every night for about 6 to 8 hours seems like it must get expensive when it comes time to paying the electric company for the large amount of power used.

Think about it on a different level. The gigantic high-power transmitting tubes used by TV stations are not only very costly, they are quite temperamental. What they particularly dislike is going through the cycle of being repeatedly shut off, getting cold, then turned back on again and

### Applications Filed For New FM Stations

AL	Palmer	95.5 MHz	51 kW
AL	Guntersville	88.5 MHz	2.2 kW
AZ	Bisbee	88.1 MHz	400 watts
CA	San Luis Obispo	88.5 MHz	3 kW
CA	Willits	91.5 MHz	6 kW
CA	Yreka	91.3 MHz	450 watts
CO	Leadville	88.9 MHz	3 kW
FL	Marathon	97.7 MHz	
IA	Indianola	88.9 MHz	1 kW
IL	Breese	97.5 MHz	6 kW
IL	DeKalb	88.5 MHz	280 watts
IL	Fairfield	105.9 MHz	6 kW
IL	Mt. Olive	105.3 MHz	6 kW
IL	Teutopolis	102.3 MHz	6 kW
MN	St. Charles	107.7 MHz	1.16 kW
MS	Hattiesburg	93.1 MHz	
MT	Ft. Belknap Agency	88.1 MHz	90 kW
NC	Hickory	90.3 MHz	150 watts
NC	Lenoir	103.3 MHz	3 kW
NY	Corning	91.1 MHz	12.6 kW
NY	Jewett	97.9 MHz	1.5 kW
NY	Whitesboro	97.9 MHz	1.7 kW
OH	N. Madison	93.7 MHz	
OR	Ashland	107.5 MHz	
OR	Eagle Point	106.3 MHz	
PA	Kane	90.1 MHz	17 kW
SD	Little Eagle	89.5 MHz	90 kW
TN	Murgreesboro	88.3 MHz	200 watts
TX	Dilley	98.9 MHz	50 kW
TX	Plainview	106.9 MHz	31.5 kW
TX	Victoria	90.7 MHz	30 kW
UT	Ephraim	89.5 MHz	100 watts
VA	Monterey	91.9 MHz	200 watts
VI	Charlotte Amalie	89.1 MHz	10 kW
VI	Frederiksted	103.5 MHz	6 kW

### Permits Issued To Construct New FM Stations

CA	Middletown	98.7 MHz	Low Power
GA	Unadilla	99.9 MHz	6 kW
IN	New Washington	88.3 MHz	1 kW
IN	Princeton	100.5 MHz	3 kW
MN	Sleepy Eye	107.3 MHz	1.13 kW
MT	Great Falls	90.9 MHz	100 kW
NY	Binghamton	91.5 MHz	560 watts
OH	Sandusky	89.5 MHz	2.12 kW
PA	Clarendon	106.9 MHz	4.7 kW
SC	Blackville	97.9 MHz	6 kW
TN	Clinton	89.9 MHz	200 watts
TX	Temple	101.7 MHz	3 kW
WV	Ravenswood	93.1 MHz	3.3 kW

### Applications Filed For New AM Stations

MT	Great Falls	1490 kHz	300 watts
OR	Waldport	1060 kHz	1 kW
WV	Parkersburg	1570 kHz	1 kW/250 watts

### Permit Issued To Construct New AM Station

FL	Palm Shores	1100 kHz	1 kW
----	-------------	----------	------

### Applied To Change AM Facilities

KIEV	Glendale, CA	870 kHz	Seeks increase to 20/3 kW.
WWCS	Canonsburg, PA	540 kHz	Seeks drop to 5 kW days.
WYSH	Clinton, TN	1380 kHz	Seeks drop to 250 watts nights.



**Hardee's**  
RESTAURANTS



A wonderful sticker from WHOT/101.1, of Youngstown, Ohio. It was sent in by Jim Viele, N8IRL, who's on the WHOT staff.

brought back up to operating temperature. The idea is that the cost of leaving the transmitter running is going to be less than paying for the consequences of turning it off every night.

One school of thought says that even a TV receiver would rather stay on continu-

ously than repeatedly go through on/off recycling. Don't let your kids know.

*New University Station:* WUSR/99.5 was recently opened by the University of Scranton. This station plays music that explores everything from rap to Rachmaninoff, and just about every category in

between. Features cover sports, women's issues, and other specialty areas.

WUSR runs 700 watts from its transmitter on Bald Mountain, 2 miles west of Scranton. The studio is on the third floor of Jefferson Hall, with the signal to the transmitter via microwave.

### FM Call Letters Changed

New	Was	
KAWV	KCKC-FM	Lake Arrowhead, CA
KAKT	KQLH	Riverside, CA
KBDR	KZZQ	Mirando City, TX
KBKL	KIOB	Grand Junction, CO
KBUZ	KZKH	Topeka, KS
KCFE	KOOU	Eden Prairie, MN
KCRL	KVTO	Rayne, LA
KDIL	KKYX-FM	Terrell Hills, TX
KDKS-FM	KZWB	Haughton, LA
KDNW	KQUH	Duluth, MN
KEDJ	KONC-FM	Sun City, AZ
KEEH	KAAR	Spokane, WA
KFAD	KDKS-FM	Alexandria, LA
KFBI	KUDA	Pahrump, ID
KFRO-FM	KLSQL	Gilmer, TX
KINK-FM	KINK	Portland, OR
KISF	KXXR	Lexington, MO
KKJZ	KLON	Long Beach, CA
KKNU	KSND	Eugene, OR
KKUZ-FM	KKID-FM	Sallisaw, OK
KMEO	KFMA	Wickenburg, AZ
KMGI	KSEI-FM	Pocatello, ID
KMPH-FM	KCML	Hanford, CA
KNKN	KGRQ	Pueblo, CO
KONE	KTEZ	Lubbock, TX
KPFX	KSMM	Fargo, ND
KPMW	KWYA	Haliimaile, HI
KPNT	KFXB	St. Genevieve, MO
KRHS	KRSH	Overland, MO
KRUU	KIAB	Boone, IA
KTLI	KBUZ	El Dorado, KS
KVLR	KDTP	Twisp, WA
KVRI	KCPX-FM	Salt Lake City, UT
KWMX-FM	KRXY-FM	Lakewood, CO
KXPT	KYRK-FM	Las Vegas, NV
KYXK	KGAP	Gurdon, AR
KYZX	KZKG	Pueblo, CO
KZDG	KDHT	Greeley, CO
WAGW	WYFA	Waynesboro, GA
WAKT	WSEA	Panama City Beach, FL
WBOZ	WBSI	Bayshore, NY
WCLB-FM	WVBF	Framingham, MA
WDCZ	WLMF	Webster, NY

WDKK-FM	WHUM	Avis, PA
WGGC	WPRX	Glasgow, NY
WGL-FM	WQTX	Roanoke, IN
WGZM	WGA-FM	Cleveland, GA
WIKX	WQLM-FM	Punta Gorda, FL
WKFM	WEQL	Fulton, NY
WKJZ	WYHE	Hillman, MI
WKNB	WJST	Pt. St. Joe, FL
WLWZ-FM	WLWZ	Easley, SC
WMBH-FM	KKUZ	Joplin, MO
WMGG	WGTR-FM	Gallipolis, OH
WMJM	WBZD	Bowling Green, KY
WMNC-FM	WQXX	Morganton, NC
WNCK	WHTK	Port Royal, SC
WNMR	WATQ-FM	New Martinsville, WV
WOGY	WODZ-FM	Germantown, TN
WOJG	WYDB	Bolivar, TN
WORD-FM	WPIT-FM	Pittsburgh, PA
WQKB	WMXP	New Kensington, PA
WRNG	WZQQ	Hyden, KY
WRZE	WNTX	Nantucket, MA
WSPI	WXMH	Mt. Carmel, PA
WTCX	KZPZ	Lakeville, MN
WVRT	WBSB	Baltimore, MD
WVVY	WKXX	Ft. Valley, GA
WWEZ	WLOT	Trenton, TN
WWOC	WXNJ	Avalon, NJ
WWYC	WHRS-FM	Winchester, KY
WXRB	WORD-FM	Pittsburgh, PA
WYFA	WAGW	Waynesboro, GA
WYGY	WZRZ	Hamilton, OH
WYUL	WEPP-FM	Chateaugay, NY

### FM Call Letter Changes Requested

Now	Seeks	
KGRQ	KNKN	Pueblo, CO
KJFK	KASR-FM	Perry, OK
KJLF	KAAR	Butte, MT
KVTY	KTJX	Mission, TX
KWCS	KBOC	Bridgeport, TX
WCNA	WSLT	Clearwater, SC
WECQ-FM	WFLK	Geneva, NY
WRRH	WJUX	Franklin Lakes, NJ
WVBS-FM	WKXB	Burgaw, NC
WWNZ-FM	WTKS	Cocoa Beach, FL

## Changed AM Call Letters

New	Was	
KCRR	KRBE	Houston, TX
KIFO	KIPO	Pearl City, HI
KINK	KGW	Portland, OR
KJLA	KIDZ	Independence, MO
KJOC	KSTT	Davenport, IA
KJQI	KGIL	San Fernando, CA
KKTR	KBOS	Fresno, CA
KOJY	KJQI	Costa Mesa, CA
KONJ	KZVE	San Antonio, TX
KTNO	KSGB	Ft. Worth, TX
KTOC	KDKS	Jonesboro, LA
KUOL	KSBL	San Marcos, TX
KWMX	KRXY	Lakewood, CO
KWSN	KFLI	Eureka, CA
KXNO	KLUC	N. Las Vegas, NV
KYYD	KORQ	Abilene, TX
WAMX	WIQB	Saline, MI
WBCR	WMDR	Alcoa, TN
WCTS	WMIN	Maplewood, MN
WDIS	WJCC	Norfolk, MA
WGBN	WKPA	New Kensington, PA
WKDL	WNTR	Silver Springs, MD
WKXX	WIBB	Macon, GA
WLOO	WMLX	Florence, KY
WLWZ	WELP	Easley, SC
WREJ	WRBN	Richmond, VA
WSHF	WXLN	Hahira, GA
WTKA	WPZA	Ann Arbor, MI
WTMM	WTMZ	Richmond, VA
WVTJ	WHYM	Pensacola, FL
WWAM	WAPO	Jasper, TN
WYCK	WTSW	Wilkes-Barre, PA

## AM Call Letter Changes Requested

New	Seeks	
KRAD	KASR	Perry, OK
KBDX	KCPX	Centerville, UT
KPLA	KCBC	Riverbank, CA
WAAJ	WLOR	Huntsville, AL
WWAX	WMXH	Olyphant, PA

We appreciate this information from Howard Johnson III, Hazleton, Penna.

*Please Remit:* The owners of Chicago AM'er WLUP were notified of an apparent liability to the FCC in the amount of \$33,750. This resulted from the FCC's claim that the station had broadcast indecent language at 11:30 a.m. and 5:30 p.m.

The agency said that these times of day "there was a reasonable risk that children may have been in the audience," which therefore caused the language to be legally actionable.

Normally, the basic dirty word fine is \$12,500 per violation. In this case it was increased because the FCC said it was repeated and because the FCC claimed that the licensee's "past compliance history includes similar apparent misconduct."

What ever became of putting 25 cents into the coffee can any time someone said a "bad word"?

Present FCC policy does not permit broadcasting anything that the agency determines to be "indecent programming" between 6 a.m. and 8 p.m. Other hours

## Changed AM Facilities

KMIS	Portageville, MO	1050 kHz	Dropped to 600 watts.
WAMN	Green Valley, WV	1040 kHz	Dropped to 2 kW nights.
WCPT	Alexandria, VA	730 kHz	Increased to 950 watts nights.
WHJM	Knoxville, TN	1180 kHz	Added nights with low power.
WIAC	San Juan, PR	740 kHz	Dropped to 3 kW nights.
WMCA	New York, NY	570 kHz	Increased to 50/30 kW.
WWLX	Lawrenceburg, TN	590 kHz	Dropped to 600 watts.

## Applied To Change FM Facilities

KBST-FM	New Madrid, MO	106.3 MHz	Seeks move to 106.5 MHz, 50 kW.
KTIG	Pequot Lakes, MN	100.1 MHz	Seeks move to 102.7 MHz, 40 kW.
KQXA	LeSeur, MN	96.1 MHz	Seeks move to Glencoe, MN.
KZBK	Brookfield, MO	97.7 MHz	Seeks move to 96.9 MHz, 27.5 kW.
WMMY	Solana, FL	105.3 MHz	Seeks move to 104.9 MHz, 6 kW.

## Changed FM Facilities

KLBQ	El Dorado, AR	99.3 MHz	Moved to 98.7 MHz, 14 kW.
KMIS-FM	New Madrid, MO	106.3 MHz	Moved to 106.5 MHz, 50 kW.
WJGF	Romney, WV	89.7 MHz	Moved to 88.1 MHz.

have become known as the "safe harbor" period. These hours could possibly be changed, pending a hearing in the D.C. Circuit Court of Appeals this fall. Let me mention that this relates only to indecent programming. The FCC advises that, in any event, "obscene broadcasts are prohibited at all times." There is a world of difference between indecent and obscene. Dirty words are only indecent. Censorship and abridgment of free speech could be considered obscene.

*Steeltown News:* WMXP/100.7, in Pittsburgh, Penna., was known as *Mixed Jams 100.7*, playing rap, hip-hop, and some top-40. It changed briefly to an all Garth Brooks format, but has now become WQKP ("K-Bear") with a country music format.

WAMO/105.9, *Hot 106* must have decided to try to gather up the abandoned former WMXP listeners. They made some slight changes in the station's format, and now call the station *Hot 106 Jams*. This station has a very potent signal.

Pittsburgh's WRRK, which was 97 *Rock*, playing new rock and heavy metal, has made some changes. Now it is *Magic 97* and runs a classic rock format. Several air personality changes have been a part of the format switch, according to Jason Reighard, Toronto, Ohio.

*Wide Area AM'casting:* A technique known as Dual Synchronous Transmission now in use on 1340 kHz in Kansas City could be something to watch for in other areas. With DST, several low power AM'ers in one region, using the same frequency, link up to simulcast. This small network provides signals over a desired region, yet offers less unwanted long-range coverage than a single high power transmitter.

In Kansas City, KNHN is networked with Pittsburg's KSEK, which is 120 miles distant. In the middle of the two, there is a third transmitter, operated as an un-



*Decal from "Radio 7," on 73.4 in Moscow. Put this on the bumper of your Ford and see how they look at you at the McDonald's drive-up window. (Thanks to Doug Marsh, Onida, S.D.)*

manned slave, to fill in the central area.

Decades ago Boston's WBZ (50 kW) and synchronized WBZA (1 kW) in Springfield, Mass. were operated like this on 1030 kHz. It means more than just placing several transmitters on the same frequency. That would merely invite heterodyning problems. The transmitters of the networked AM stations in the same region must be carefully synchronized in order to operate simultaneously on a single frequency.

*Hit The Jackpot:* A \$250,000 Notice of Apparent Liability was sent to the licensee of 6 Texas FM stations, and a hearing was designated regarding the renewal applications of the stations. We think he hit the jackpot.

The FCC claims that their investigation showed that he built and operated 3 non-commercial educational FM stations in Texas "without appropriate authorization." These were KLMN (Amarillo), KAMY (Lubbock), and KENT-FM (Odessa). Also, the agency claimed he "misrepresented facts and/or lacked candor" about



## New FM Call Letters Issued

KCVN	Faribault, MN
KGOZ	Gallatin, MO
KNJP	Sargent, NE
KNJS	Belle Plaine, IA
KNJT	Eunice, NM
KNJU	Raton, NM
KNJV	Royal City, WA
KOUY	Belle Plaine, KS
KOUZ	Alexandria, LA
KPRG	Agana, GU
KYFF	Fort Smith, AR
KZBE	Pleasant Hope, MO
WAYL	St. Augustine, FL
WEJS	Bar Harbor, ME
WFMV	S. Congaree, SC
WHPL	W. Lafayette, IN
WLGD	Columbia, FL
WLGE	Ocean City, MD
WLGG	Woodville, MS
WLGJ	Manchester, NH
WLGK	S. Waverly, PA
WLGU	Keene, NH
WLGV	Murrysville, PA
WLGX	Carolina Beach, SC
WLGZ	Pattersonville, NY
WLJI	Summerton, SC
WLJJ	Union City, TN
WLJL	Charlottesville, VA
WLJO	Lacross, WI
WLJQ	Colonial Hts., TN
WLJR	Birmingham, AL
WLJU	Brookfield, WI
WLJW	Jamestown, NY
WPVQ	Turners Falls, MA
WQVA	Semora, NC
WSJD	Princeton, IN
WTKO	Samsula, FL
WWMC	Lynchburg, VA
WWSG	Sylvester, GA
WZLC	Oglesby, IL



Oldies station KARA/105.7 is in San Jose, Calif.

his activities when he submitted documents to the FCC.

These matters brought about the NAL. The FCC wants to review whether he is qualified to hold a license. The FCC is also looking into an existing permit he holds to construct KBTT in Bridgeport, Texas. The agency wants to think about an application he has filed to obtain a permit to construct a station in Stanton, Texas.

Time to make some entries in the station log, so we will be signing off for July. Back with you soon. Keep those letters, questions, bumper stickers, decals, news clippings, station photos, and format changes pointed in our direction. ■

# Answers! Answers! Answers!

## CQ's New 1993 Beginner's Guide to Amateur Radio

New hams—Novices, Techs, Generals or whatever ticket you start with—have questions. What do I look for in an HT? How should I operate on the local repeaters? What's it like to get on HF? How do I set up a station? How do I use an SWR bridge? These questions and a hundred more. As important as these problems are, there's one other question that's more important: Where can I go to find the answers?

### CQ's 1993 Guide To Amateur Radio

will answer these questions and hundreds of others. This new guide is chock-full of articles written strictly for the newcomer by some of the best writers in Ham Radio. Bill Orr, W6SAI, shows you how to efficiently set up your first station. Lew McCoy, W1ICP, takes you on a tour of repeater operating practices and etiquette. McCoy also tells you what an SWR bridge is and how to use it, as well as recommending the best type of SWR indicator for newcomers. Ed Juge, W5TOO, gives you a concise guide to the common and not-so-common functions and capabilities found in today's handhelds. Famous ham educator Gordon West, WB6NOA, guides you through the licensing and upgrading maze. John Dorr, K1AR, shows you how to set up your first packet station and make that first connect. There's even an article that gives you the secrets of successfully installing PL-259s—no small task even for old timers. You'll find many, many more articles that you'll want to refer to often. Also, you'll find detailed information on many of the most popular rigs plus an explanation of what everything means—a mini buyer's guide of sorts. Plus, you'll find an up-to-date listing of all the Ham Radio manufacturers and dealers. You'll want to keep this book handy for day-in-day-out operation. It will pay for itself with every article you read.

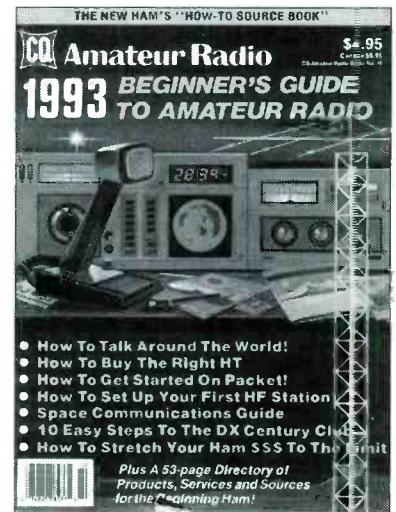

**YES, please send me \_\_\_\_\_ copies of CQ's 1993 Guide To Amateur Radio at \$4.95 each:**

Name \_\_\_\_\_ Call \_\_\_\_\_

Address \_\_\_\_\_

City \_\_\_\_\_ State \_\_\_\_\_ Zip \_\_\_\_\_

Send only \$4.95 each (plus \$2.50 shipping & handling, \$3.50 foreign)

Check       Money Order       MasterCard       VISA       AMEX

My account number is: \_\_\_\_\_ expiration date \_\_\_\_\_

--	--	--	--

Mail to: CQ Communications, Inc.  
76 North Broadway, Hicksville, NY 11801  
Phone: 516-681-2922 FAX: 516-681-2926

# TELEPHONES ENROUTE

BY TOM KNEITEL, K2AES

## WHAT'S HAPPENING WITH CELLULAR, MARINE & MOBILE PHONES

**R**eports continue to surface concerning illegally cloned cellphones used to make free calls. With minimal effort, cellulars are being provided with false electronic identities that are good enough to get calls passed. It may take about a month before fraud is detected for any given cellphone, and by then the bogus phone may have been used to run up as much as \$50,000 in worldwide toll calls.

The latest techniques can be used with virtually any home computer loaded with software available to professional cellular hackers, who then sell the cloned phones to drug dealers and others seeking untraceable numbers.

The trick is for the cellular hacker to acquire operational data for many legitimate cellphones. The vital data needed to be stolen is the "NAM" (telephone number assigned to the subscriber), and the "ESN" (permanent factory-issued electronic serial number of the specific phone). These two pieces of data are automatically transmitted with each call, then matched with current data in the cellular service company's computer. If the match is good, the call goes through.

Cellular hackers have receivers that can read this data when it is transmitted. As cellular calls are placed, the hackers acquire valid NAM and ESN data, then record it for cloning into bogus cellphones. The actual cloning is so easy that it requires nothing more than having the right software, then feeding new data into a cellphone through a cable plugged into its battery connector.

The old cellular hacking method of replacing microchips with pirate chips required far more technical skill, time, effort, parts, and expense. It didn't even have the success rate of this newer method.

This is a growing criminal problem, and is spreading quickly. Arrests have been made, but the underground folks performing this work find a ready market eager for their services. If you open your monthly bill to find your toll charges especially high, you must consider the probability of your number having been ripped off by professional cellular hackers. Complain immediately to the cellular company, demanding your NAM be changed at no additional cost to you.

### Digital Phone News

NYNEX Mobile Communications and Qualcomm Incorporated are testing digital cellular tests using Qualcomm's Code Division Multiple Access (CDMA) equipment. The equipment will be installed in Motorola's headquarters in Orangeburg, N.Y.

Tests will verify CDMA's ability to meet

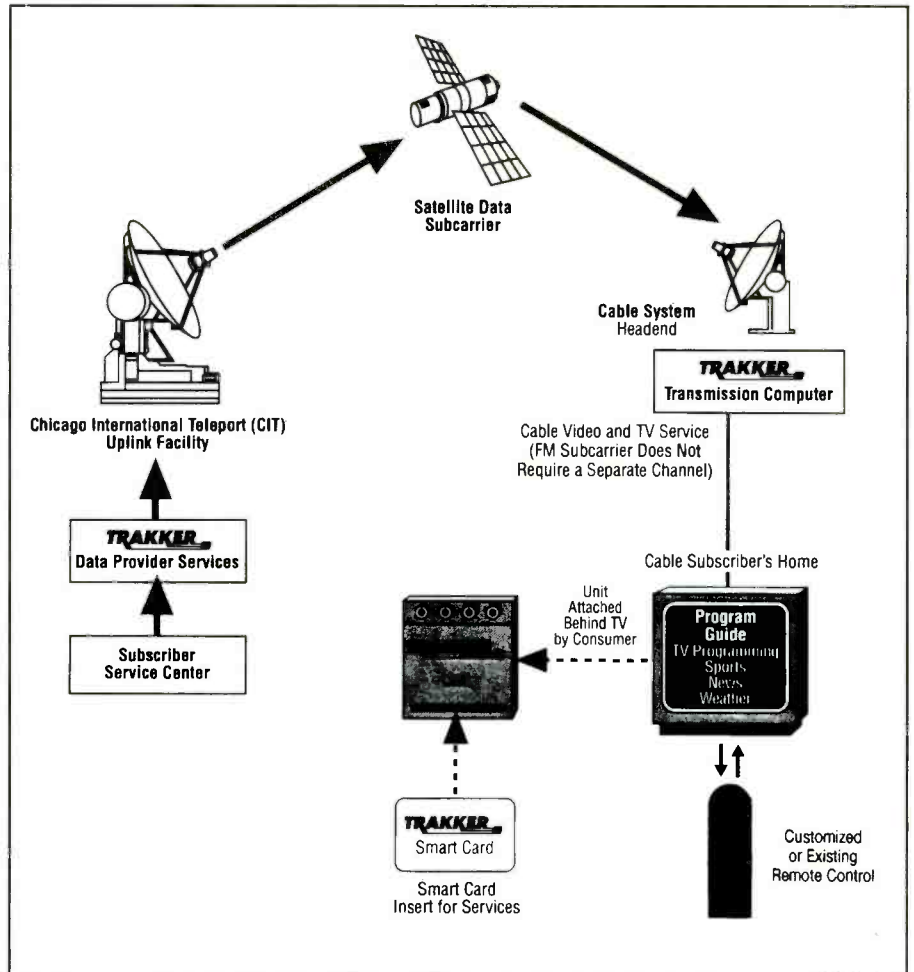

Here's a pictorial of how Trakker Interactive Services reaches a subscriber's home.

critical digital cellular and Personal Communications Services (PCS) requirements such as high mobility, low power transmission, high quality, capacity, and signal coverage.

Motorola's SC-9600 base station equipment can support a wide variety of both analog and digital modes (AMPS, NAMPS, TDMA, CDMA) within the same cabinets. Versions are available for the 800 and 1500 MHz frequency ranges. The high frequency band is used in some Latin American nations.

Kenwood Corporation concluded a contract with Tokyo Digitalphone Co., Ltd. (TDP) to develop digital portable mobile telephones. These units will operate in the 1500 MHz band.

### Dual Mode

Keeping alert to the coming digital market while remaining operational in the ex-

isting analog cellular format, the Murata/Muratec CT-150 cellphone is a dual-mode device.

With its dual-mode capability, the CT-150 operates with analog AMPS systems as well as the new digital Time Division Multiple Access (TDMA) systems. That makes it suitable for every cellular market or system in existence now or those being phased into use.

Although it is a small handheld, the CT-150 has many features. For instance, it will accept five different NAM's, and automatically recognize which one to use in the area where the phone is being used. It has a built-in answering machine that allows callers to leave voice messages. The low-battery warning lets you know in minutes how much time is left before a recharge is needed. There is an optional PC link interface. You can program 200 roam access numbers and cities into its memory.

Nickel-metal hydride batteries offer 70



minutes of talk-time in analog mode, or 95 minutes in digital mode. You get 12 hours of stand-by on a single battery charge.

This radio is extremely user-friendly, and looks like it encompasses many clever concepts.

For more information, contact Muratec, 5560 Tennyson Parkway, Plano, TX 75024-3099.

### Trakker Interactive

The new TV Trakker system is an interactive concept that provides information to consumers on their TV screens. Sports, news, entertainment, weather, business, and other updated data can be accessed by the viewer. Other information and services can be summoned upon demand by a subscribing viewer, who follows an on-screen menu to select exactly what is needed.

Shopping-at-home, VCR programming, polling, surveys, banking, and many other conveniences are things that are within the realm of interactive TV. The TV Trakker system makes use of satellite technology and the subcarriers of cable TV signals. It has been in use on the Cox Cable system in Omaha, Nebraska, since November of last year.

This service is available at relatively low cost to individual subscribers. It has been extremely successful in Omaha and will soon be available in other areas.

The service is offered by Trakker Interactive Services, 7130 South Lewis, Suite 410, Tulsa, OK 74136.

### Cellular Etiquette

PacTel offers ideas for cellular phone etiquette that are worth remembering.

1. If you let people know that you are reachable, then be sure to keep your cellular on stand-by so they can get through to you.

2. Always ask the person you are with if they mind if you take or make a cellular call, and excuse yourself when you do.

3. Don't use the phone in a theatre, formal business meeting, child's recital, or place of worship. If you use your phone in any public place, make certain that others won't be disturbed.

You no doubt can think of about a dozen other suggestions, but wouldn't you settle for most cellular users carrying the ball with even two of these three?

### New US/Canadian Cellular Service

Fifteen cellular companies announced a new service to offer constant levels to improved cellular calling across both nations. Called *MobiLink*, cellular service is promised to be easier and accessible to more people.

It will allow people to more easily make and receive calls using standardized dialing codes in major metropolitan areas. Also



The Murata/Muratec CT-150 is a dual-mode analog/digital cellular that offers some clever features.

provided will be 24-hour customer service, repair centers, and loaner phones.

In the USA, *MobiLink* will be available only through wireline cellular operators. In Canada, it will be offered by Mobility Canada.

Cellular subscribers belonging to *MobiLink* will be able to dial \*611 (Star-611) on their cellular, or an 800 telephone number, that will connect them directly back to their local carriers' customer service.

The service will be available in the last quarter of this year and will be announced through local cellular carriers. Membership will be available through those local carriers. Watch for announcements, which will most likely be included with monthly bills.

### Up In The Air

GTE Airfone tells us that they have now logged more than 25-million air/ground telephone calls via their in-flight service. There are now 1,965 airliners operated by twelve companies using the GTE Airfones.

Another company, The In-Flight Phone Corp. (IFPC), tells us that ABC Radio Networks will be the major supplier of programming for FlightLink On-The-Air. The

live airborne audio system will digitally transmit up to twelve channels of stereo programming to passengers aboard commercial and corporate aircraft.

A network of 50 ground stations will continuously transmit multiple channels of programming to the aircraft. Aircraft will pick up the signals and digitally distribute the stereo throughout the cabin. Passengers can select the channel desired to monitor. Most programming will be free, although some special sports or premium entertainment events will be available at extra cost (and may be paid for with a charge card).

The technology for this system was developed by Harris Corp. In-Flight Phone Corp. which is headquartered in Oakbrook Terrace, Illinois.

### Timed Out For June

Looking for your news clippings and thoughts on cellphones, pagers, and other personal communications. We are also seeking new product data, and information on new personal communication services.

## Go SPECTRA 4-Band Scanner Mobile/Base Antenna

Austin's 4-band, patented, Spectra scanner antenna brings you unparalleled reception performance on VHF-Low, VHF-High, UHF, and 800 to 1000 MHz Cellular. You can even replace your Cellular phone antenna with the Spectra and receive the other bands to boot!

**only \$79.00**

Optional Magnet Mount only \$19.99

Spectra with optional pole mount for base station with improved VHF-Low band performance only \$132.95

30-day money-back guarantee if not satisfied with the Spectra antenna.

**1-800-950-WARE**

Write for your FREE 56 page catalog

**RADIOWARE**



PO Box 1478, Westford MA 01886

CIRCLE 73 ON READER SERVICE CARD

## 27 MHz COMMUNICATIONS ACTIVITIES

**T**o those who always ask why they don't make those great SSB base station rigs any longer, I would say not to forget the trusty Cobra 142GTL. This excellent AM/SSB transceiver has been continually in production for several years, ranking up there with the best of them. Certainly, the Cobra 142GTL is intended for the serious sideband operator who demands quality and performance.

The 142GTL features modular design. The receiver has a six-pole lattice-filter. The selectivity is 6 dB at 4.2 kHz and 60 dB at 7 kHz. Adjacent channel rejection is 60 dB on AM, 65 dB on SSB. The clarifier tunes 1.5 kHz above and 1.5 kHz center slot. Sensitivity is better than 0.5 uV.

The transmitter has a logarithmic speech processor to deliver powerful and clear modulation with no flat-topping or splatter.

Among the features are dual backlit panel meters to measure SWR/modulation percentage, and S/RF power; variable mike output; RF gain control; switchable ANL and NB, and transmit/receive indicators.

As you can see, this is a marvelous machine. It even looks wonderful sitting in a radio room. Comes from Cobra Communications Div. of Dynascan Corp., 6460 West Cortland, Chicago, IL 60635. Many dealers carry Cobra radios.

### Customized Pioneers

In the very early days of CB radio the selection of commercial equipment was somewhat slim. CB radios tended to lean towards the dinky rather than the deluxe. Many operators bypassed this problem by assembling their own customized deluxe CB transceivers. These were usually made



*This clever 1962 CB'er built his customized CB rig to overcome common problems like transmitters having too few channels, and receivers with poor selectivity.*

from converted military surplus radios, or built up with existing CB radios as their cores.

We can show you two, although there were many other one-of-a-kind customized deluxe CB transceivers in use 30 years ago.

In 1961, a California CB'er named Frank Baker had what he called a "Collins" CB radio. The beautiful rig even bore the Collins label. It actually was somewhat of a Collins set. It had 12 transmit channels, a tunable receiver, squelch, front panel

antenna tuner as well as peaking for both buffer stages and the final, front panel antenna tuning. Baker had customized this radio from a U.S. Navy type NBF transceiver, which had been made by Collins.

In 1962, Clifford Smith, of West Virginia, said he thought that CB transmitters were OK, except they didn't offer enough transmit channels. Primarily, he didn't like existing CB receivers. They tuned so broadly that he could never hear less than three channels at one time.

**SANLAW**

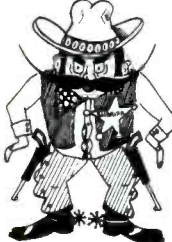

**KZA**  
**6724**

**Clif & Pon**  
**Freligh**

Background PEANUTS

**THAI LADY**



**SSB 3447 SWS 1869 Gold Coast 3586 SR 869**

New Mexico's Clif, SSB-3447, is a veteran sideband operator. He tells us that he never misses our column! His famous QSL hangs on radio room walls from Albuquerque to the Alps.

**"NIGHT EAGLE"**

**DS-397**  
**SSB-72F**  
**KSR-579Z**

**GLENN HENDRIX**  
RT. 3 36X 174F  
ARDMORE, OK 73401



**QSL 100%**

*Browning Golden Eagle Base*  
*"The Eagle Keeper"*

This QSL from Glenn, SSB Network member SSB-72F, of Oklahoma, runs a 20-plus over 9 on our meter!





A Collins CB rig? In a way, it was. But that was a long time ago.

Clifford then designed his own customized CB radio around a modified commercial CB transmitter. He added provisions for transmitting on all 23 channels, plus peaking and metering the transmitter output. The CB receiving functions were handled via an automobile radio which fed the CB signals at its 455 kHz IF frequency. This offered excellent selectivity. The receiver was also given an S-meter. The entire rig was completely repackaged by Clifford, then topped off with a great Astatic D-104 crystal mike. Beautiful job in every respect.

These are two examples of early CB radio equipment that were colorful and unique.

### Happy Birthday, "Lollypop"!

Let's mention here that 1993 marks the 60th anniversary of Astatic's famous D-104 mike design, which has lovingly become known to hams and CB operators around the world as The Lollypop. Easily the most famous comms microphone ever made, it began its career in 1933 as a crystal mic. These days, they are made in amplified crystal, ceramic, or dynamic designs. They offer superb talk power and utilize

that unique stand with the grip-to-talk bar, and a heavy base that resists toppling.

To mark the special occasion, this year (only) Astatic is producing a Limited Edition 60th Anniversary Diamond Eagle version of the D-104. This is a fully functional amplified crystal mic, custom plated in bright brass (looks like shiny gold). There is a full cut 8-point diamond mounted in the engraved eagle backplate. A nameplate is provided for engraving the owner's name or ID. A certificate of authenticity comes with each of these mikes.

These impressive commemorative mics are available from Astatic dealers, who also carry other fine products from this worthy company. For more information, contact Astatic, P.O. Box 120, Conneaut, OH 44030, or circle 101 on our Readers' Service.

### A Peek Into The Mail Sack

We heard from Cliff, SSB Network member SSB-3447, of Albuquerque, New Mexico. He monitors 38-Lower, and each Sunday he runs a roll call on 16-Upper. Cliff tells us that he remembers our scribbles in the old *S9 Magazine*, and asks if we can figure out how long he has been one of our loyal readers. We figure that's got to be sometime in the mid-1970's, Cliff.



Cobra's venerable 142GTL AM/SSB base station radio.

## SUPER 12 HOUR RECORDER

CALL TOLL FREE

Modified Panasonic Slimline. 6 hrs per side. 120 TDK tape furnished. AC/DC Operation. Quality Playback. Digital Counter. Durable Lightweight Plastic.



\$119.00\*

### PHONE RECORDING ADAPTER

Starts & Stops Recorder Automatically When Hand Set is Used. Solid State!

FCC APPROVED

\$28.50\*



### VOX VOICE ACTIVATED CONTROL

Solidstate Adjustable Sensitivity. Voices & Sounds Activate Recorder. Adjustable Sensitivity. Provisions for Remote Mike.



\*Add for ship. & handling. Phone Adapter & Vox \$2.00 each, Recorders \$5.00 each, Colo. Res. add tax. Mail Order, VISA, M/C, COD's OK. Money Back Guar. Qty. Disc. available. Dealer inquiries invited. Free data on other products.

ALL MAIL TO: Box 20100, Boulder, CO 80308  
AMC SALES INC., 193 Vaquero Dr.,  
Boulder, CO 80303  
Phones (303) 499-5405 • 1-800-926-2488  
FAX (303) 494-4924 • Mon-Fri 8-5 MTN. TIME

CIRCLE 50 ON READER SERVICE CARD

## The HB-232 SCANNER/COMPUTER INTERFACE

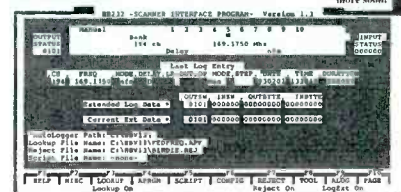

### REVOLUTIONIZES THE ART, SCIENCE & PLEASURE OF SCANNING!

The HB-232 is the long awaited RS-232 scanner controller and data acquisition system brought to you by Bill Cheek, author of the *Scanner Modification Handbooks*.

The HB-232 Scanner/Computer Interface Kit + includes:

- printed circuit board and essential electronic parts
- Control Program on Disk; (specify disk size)
- detailed documentation & photos on assembly, installation & operation
- wide area network technical support

+ Requires PC/XT/clone w/MS-DOS 3.1 or higher & 512-K RAM min; HD recommended

Designed for the PRO-2004/5/6 scanner series, the HB-232 features AutoLog, AutoProgram, Data LookUp, Scripts & much more with nearly unlimited variations of computer control & data collection from the scanner. Facilitates maximum performance without compromise. Easy to install & use; minimal invasion to scanner! Discover a new dimension of radio scanning! Order today! \$194.95 + \$5 S&H, ck, m.o. MC/VISA. SEE FOR MORE INFO.

\* Reduced capability for PRO-43

**COMMtronic Engineering**  
P.O. Box 262478-P  
San Diego, CA 92196-2478  
(619) 578-9247

1:30pm-5:30pm, PST: Voice Only  
6:00pm-1:00pm, PST: BBS & FAX Only

CIRCLE 56 ON READER SERVICE CARD

Clif remembers the old Small World Society, as he is member SWS-1869. He wonders how many other SWS members are still around. Hey Clif, our SWS certificate still hangs on the wall here. Always good to hear from old friends.

A lengthy letter from Scott Moore berates operators who refuse to accept helpful technical advice from other operators relating to how to improve their signals. He also gets annoyed with people who never have conversations but, instead, ask for radio checks every couple of minutes. Lastly, Scott would like to see SSB manufacturers add features like Roger Beep, selcall, and a notch filter. He points out that a ham rig such as the RCI-2950

sells in the \$250 price range and yet contains many more fancy operating features than SSB CB rigs selling for about the same price. Yet those features could easily, and legally, be added to the CB radios by manufacturers.

A reader purchased a used CB base station radio carrying the ID Handic USA Model 2305. There was no documentation with this radio, but on the rear of the radio there was an address in Miami Lakes, Florida. His letter to that address was returned from Hialeah stamped with a notice that the forwarding time had expired. He needs an instruction book or service manual in order to service the squelch, which has a minor problem. Can



Emblem of the Triangle Area CB Network, North Carolina.

**SALE! Tone-Master™**



Touch Tone Decoder

MoTron Electronics  
310 Garfield St., Suite 4  
Eugene OR 97402

Orders: (800) 338-9058 • Info: (503) 687-2118 • Fax: (503) 687-2492

Decode and display Touch-Tones from a telephone, tape recorder, scanner, or nearly any audio source.  
√16 digit LCD display, 80 digit scrollable buffer  
√ Built-in speaker √ 9V battery √ Metal case  
√ TM-16 PLUS includes RS-232 output and Software for optional automatic date/time/number logging using your IBM Compatible computer

TM-16 Standard Model	\$169	<del>\$229</del>
TM-16 PLUS RS-232 Model with Software	\$299	<del>\$399</del>
PS-12 AC Power Adaptor	\$10	\$239

S/H \$5 USA/Canada, \$15 Foreign.

30 day money back guarantee! Try at no risk!

Visa, MasterCard & American Express Accepted

(Touch-Tone® is a registered trademark of AT&T)

## YOU AIN'T HEARD NOTHIN' . . . YET

Since 1967, CRB Research has been the world's leading publisher and supplier of unique hobby and professional books and information including:

- Scanner Frequency Guides
- Shortwave Frequency Guides
- Military/Federal Communications
- Broadcast Station Registries
- Undercover Communications
- Survival Communications
- Covert Operations
- & Other Related Topics!

**Ask for Big  
Free Catalog**

New titles are constantly being added to our exciting catalog. If it's interesting and unusual, we've got it. You'll see. Ask for our latest FREE catalog.

Business Hours: 9 am to 3 pm Eastern (Mon., Tues., Thurs., Fri.). Closed Wed. and Holidays.

**CRB RESEARCH**

P.O. Box 56

Commack, NY 11725

Phone: (516) 543-9169/FAX: (516) 543-7486

any reader help with information on the current address of this company, or with photocopies of documentation? The chap looking for info is Hal Brooke, SSB-84U, 1663 East Fork Road, Sula, MT 59871.

Handic was (and may still be) a leading Swedish CB manufacturer. The company was active in the US market during the late 1970's, but we haven't heard anything about it in years.

Mark Ke'koa is originally from Hawaii, but presently lives in Ohio. Mark tells us that Hawaii is very active on Channel 11 for AM'ers, with SSB'ers on 36 through 40 LSB and USB. In the area of Steubenville, Ohio, which is where Mark now yaks, he monitors AM on Channel 17, and all the usual SSB frequencies.

Thanks to Albert Nunnery, SSB Network member SSB-67U, of Cary, N.C. for sending along the baseball cap and great-looking shoulder patch from the Triangle Area CB Network. The Triangle group operates in Albert's local area, and he is a charter member. Really appreciated, Albert.

Sitting here in the depths of summer, it's good to hear from Brian, 33-DV-158, who lives in a remote area of comfortable and cool Alaska. Brian tells us that in the remote wilderness area where he is located, his radios are the only contact he has with the outside world. They are his life-line. He runs a President Grant and a Cobra 142GTL. Both have been hacked to enhance and add features.

Brian wants the FCC to open up the frequencies between 27.405 and 27.995 MHz for legal CB use, allowing more than 4 watts, additional transmission modes, and a certain amount of home-built equipment. He feels it will add to the enjoyment of communications, while not taking anything away from anybody. While waiting for this to happen, Brian monitors the upper side of 27.555 MHz.

A goodly stack of mail, and we hope to hear from you, too. Send along your shack photos, your QSL's (or any DX QSL's you want to share with our readers), your opinions, newspaper clippings regarding CB, questions, or whatever. ■



# HOW I GOT STARTED

**P**opular Communications invites readers to submit, in approximately 150 words (more or less), how they got started in the communications hobby. They should preferably be typewritten, or otherwise easily readable. If possible, a photo of the submitter should be included.

Each month we will select one entry and run it here. You need submit your entry only once, we'll keep it on file. All submissions become the property of *Popular Communications*, and none can be acknowledged or returned. Entries will be selected for use taking into consideration if the story they relate is especially interesting, unusual, or even humorous. We reserve the right to edit all material for length and grammar, and to improve style. The person whose entry is selected will receive a one-year gift subscription (or one-year subscription extension) to *Popular Communications*.

Address all entries to: How I Got Started, Popular Communications, 76 North Broadway, Hicksville, NY 11801.

## Our July Winner

This month our winner is Richard G. Johnson, Pittsburgh, Pennsylvania. Richard told us:

"My first experience with radio was in Virginia during the summer of 1961 when, at age 3, I figured out how to get into my father's red 1960 Ford. I managed to press the button on the microphone button of the Viking Messenger I CB transceiver and—to the horror of several family members—send my voice through the base station CB radio in the house. I don't think I used the callsign, but it was KCJ4731.

"Eventually, I grew old enough for the FCC to issue me a CB license, and I became KKL9951. That Viking Messenger is still working flawlessly!

"I recall putting together a demonstration of a relay station for my 7th grade classmates. Using CB frequencies, my line-of-sight relay spanned two classrooms, and carried voice and microphone-click transmissions using coat-hanger antennas." ■



Rick Johnson describes this as his "cigar-box" radio. It's a cigar box outfitted with two shortwave portables and two scanners. Havana good time with it, Rick?

## SHOCKING MANUALS!!

Survival Electronics, Computers, Security, Weaponry, Rocketry, Phones, Energy, Financial, Medical. 100+ offers include Special Projects and Technical Research Services, and hardware. Confidentiality Guaranteed! Send \$4 for new Combined Catalog. By John Williams, former Senior Engineer (Lockheed), Professor of Computer Science (NMSU). As seen on CBS "60 Minutes." Since 1971

**CELLULAR PHONE MANUAL:** Detailed manual on how cellular phones are re-programmed (ESNs and NAMS) and scanned. 30+ cellular phone models described. Specific scanner mode \$39.

**VOICE MAIL BOX HACKING:** Step-by-step descriptions of how 8 popular voice mail PBX systems are hacked. \$29.

**BEYOND VAN ECK PHREAKING:** Plans for surveillance systems some use to eavesdrop on TVs and computer monitors. \$29.

**SECRET & SURVIVAL RADIO:** Detailed manual describes the optimum freqs, equipment, modes and circuits for secret, survival and security situations. Includes small transmitters and receivers; ultrasonic, infrared and fiberoptic commo, improvising and optimizing antennas. 70+ circuit diagrams. \$29.

**COMPUTER PHREAKING:** Detailed manual describes both computer viruses and how computers are penetrated. Includes 2 PC disks [1] FLUSHOUT: protection system. [2] Disk loaded with hacker files. \$39.

Many more: **STEALTH TECHNOLOGY** (\$19), **PHONE COLOR BOXES** (\$29), **TV DECODERS & CONVERTERS** (\$14), **STOPPING POWER METERS** (\$19), **RADIOLOGICAL MANUAL** (\$29), **EM BRAINBLASTER** (\$29), **UNDER ATTACK** (\$29), **HIGH VOLTAGE DEVICES** (\$29), **DISK SERVICE MANUAL** (\$29), **ATM** (\$39). Include \$4 S/H. Educational purposes only.

## CONSUMERTRONICS

2011 CRESCENT, P.O. DRAWER 537, ALAMOGORDO, NM 88310  
 VOICE: (505) 434-0234, 434-1778 (8AM-9PM MST, Mon-Sat.)  
 FAX: 434-0234 (orders only, 24-hours, 7 days/week. If you get answering machine press "8" then "1" any time.)

CIRCLE 58 ON READER SERVICE CARD

**FREE  
 SAMPLE  
 COPY!**

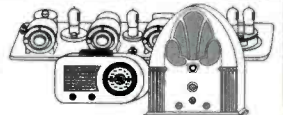

## ANTIQUE RADIO CLASSIFIED

*Antique Radio's Largest-Circulation  
 Monthly Magazine*

Articles - Classifieds - Ads for Parts & Services

Also: Early TV, Ham Equip., Books, Telegraph, 40's & 50's Radios & more...

Free 20-word ad each month. Don't miss out!

1-Year: \$29.95 (\$44.95 by 1st Class)

6-Month Trial - \$16.95. Foreign - Write.

A.R.C., P.O. Box 802-T8, Carlisle, MA 01741



Or Call: (508) 371-0512



## VIDEO SYNC GENERATOR



Restores Horizontal  
 and Vertical

Sync Lines from Distorted  
 Analogue Video Formats

For Free Information Package on Completed Units and Pricing



Call 219-236-5776



R.C. Distributing • PO Box 552 • South Bend, IN 46624

CIRCLE 71 ON READER SERVICE CARD

## WORLDS SMALLEST FM TRANSMITTERS

NEW! POWERFUL! ULTRA-MINIATURE FM TRANSMITTER KITS

Surface Mount Technology (SMT) makes these the smallest high performance transmitters available anywhere! Use them with any broadcast FM receiver. Complete, easy to assemble kits with all SMT parts already assembled to the circuit board.

XST500 - Voice transmitter includes a super sensitive microphone to transmit voices at the level of a whisper up to a mile away.

XST500 ..... \$44.95

XPS250 - Phone transmitter uses no batteries, attaches to your phone line, and transmits conversations up to 1/4 mile away.

XSP250 ..... \$34.95



WE ACCEPT CHECK, VISA, MC, MO, OR COD (\$ & H EXTRA)



SATISFACTION GUARANTEED  
 CALL: 1-800-336-7389

KANDI ELECTRONICS - SINCE 1981  
 201 E Southern Ave, Suite 111, Tempe, AZ 85282



**ASK FOR  
 CATALOG**

CIRCLE 78 ON READER SERVICE CARD

## INSIDE THE WORLD OF SATELLITE COMMUNICATIONS

### AMSAT—The Future

**A**MSAT is an acronym for the Radio Amateur Satellite Corporation. The Amateur Space Program (ASP), under the leadership of President Bill Tynan (W3XO), is always looking to the future. Amateur Radio has become a regular part of NASA programs through the Shuttle Amateur Radio Experiments (SAREX), which include voice, packet and ATV operations. This along with AMSAT's current International fleet of digital (Packet) and analog (SSB/CW/ATV) satellites has shown once again that Amateur Radio is on the cutting edge of new satellite technology. We now continue our conversation with Bill Tynan:

*What are Packet satellites (PAC-SATS)?* "They are flying computers with large memory and radio transponders. The concept is to upload a message at one point and download a message at another point on the earth. The ground stations check the satellite's memory for messages much like a VHF or telephone BBS. The low earth orbit packet satellite concept has been picked-up by both government corporate interest. It is a cheap way to send information anywhere in the world if you don't need real-time communications."

*How is satellite packet different from regular packet?* "The satellites are farther away and of much lower power than regular packet. Most packsats (AO-16, DO-17, WO-18, LO-19) use 1200 baud and Phas Shift Keying (PSK or BPSK) instead of AFSK like VHF packet. The English UOsat (UO-22) is really a second generation satellite. It uses 9600 baud rate. A second UOsat (UO-14) has been given over to commercial use as a medical satellite. Both spacecraft were built by AMSAT-UK and the University of Surry. Both carry commercial equipment onboard. Our next packet satellite will likely be a 9600 baud."

*What can you tell me about the French RSAT?* "It uses AFSK at 1200 baud. It was built in 1986 and has been waiting for a launch vehicle. It was scheduled for launch in April and should be an interesting experiment. It will have a high orbit and will be seen by a lot of people at once."

*What are gateway stations?* "Well, there are digital and voice gateways. There are several Packet (digital) gateways in the US. You would need to contact your local SYSOP for the nearest station. These stations are simply satellite stations that operate as a relay for other stations by taking their digital or voice signal and uplinking and downlinking it through the satellites. The voice gateways were largely experi-

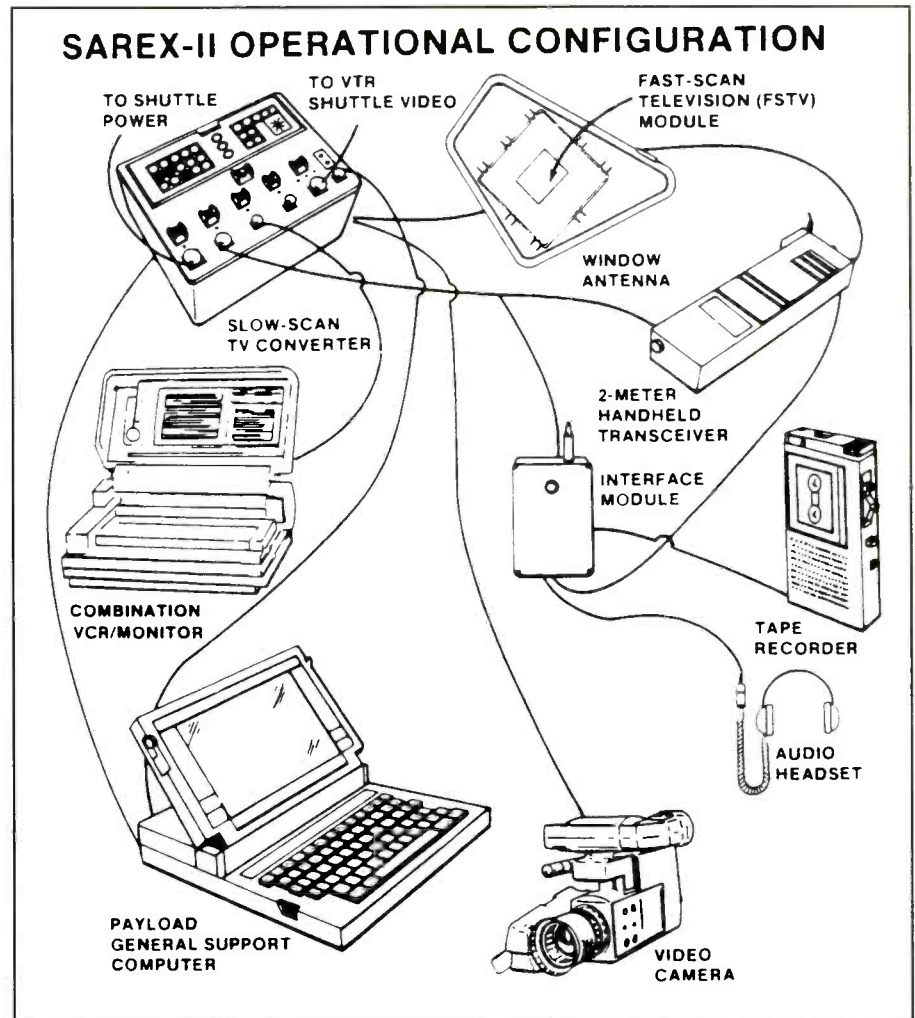

mental in nature. Satellite signals are relatively weak, something less than S9 most of the time. Many people today are not satisfied with that. They think they need a telephone quality FM signal or it is not copyable. Many operators have lost the ability to copy under difficult conditions. They seem to have been spoiled by our extensive high quality network of FM repeaters here in the US."

*Does AMSAT have non-amateur members?* "Yes, we welcome everyone. We have two missions if you will. One is to educate people about satellites and space communications and second, we encourage people to consider the advantages of getting their Amateur Radio license. And with the no-code that is not difficult to do."

We are always looking for people with special skills who would be willing to contribute to the over-all success of our mission. We always need people with techni-

cal and administrative skills. One of the things I am doing for the next copy of the AMSAT Journal is an inventory list. We want to know what special skills our organization needs the most. We need everything from accountants to electrical engineers. Many of our volunteers are educators, engineers, scientists, and hobbyists. Their contributions make a difference."

*Will space station Freedom be amateur equipped?* "Well, the proposal has been made and updated a couple of times. We are still pushing for that and SAREX (Shuttle Amateur Radio Experiment) program is a precursor to that. Amateur Radio has become quite popular with the astronauts. As more and more get licenses there is not enough time available for all of them to take part in a SAREX mission. It looks like two types of amateur shuttle missions are developing. The official SAREX missions, with pre-planned experiments and a



# AMSAT

Radio Amateur Satellite Corporation  
850 Sligo Ave., Silver Spring, MD 20910  
301-589-6062

## CURRENTLY ACTIVE AMATEUR RADIO SATELLITES

Satellite	Mode	Uplink (MHz)	Downlink (MHz)
PACSAT (AO-16)	1200 bps PSK AX.25	145.900/920/940/960	437.025 437.050 (Sec.) 2401.100
DOVE (DO-17)	1200 bps AFSK/digital voice *		145.825 2401.220
WEBER (WO-18)	1200 bps PSK AX.25		437.075 437.100 (Sec.)
LUSAT (LO-19)	1200 bps PSK AX.25	145.900/880/860/840	437.150 437.125 (Sec.)
JAS-1b (FO-20)	JA (Analog) JA Beacon	145.900-146.000	435.900-435.800 435.795 CW
	JD (1200 bps PSK AX.25) JD Beacon	145.850/890/910	435.910 435.910
OSCAR 21 (RS-14) Transponder #1 (Primary)	B (Linear)	435.102-435.022	145.852-145.932
	(Digital)	RX-1 435.016 RX-2 435.115 RX-3a 435.193 RX-3b 435.193 RX-4 435.041	145.983
Transponder #2 (Secondary)	B (Linear)	435.123-435.043	145.866-145.946
UO-22	9600 BPS FSK	145.900	435.120

### Notes:

\*DOVE will not have user access uplink. Instead, it provides AFSK AX.25 telemetry and digitized voice messages (when activated).

†The AO-21 RUDAK uplinks are as follows:

- RX-1 1200 BPS NRZIC Bi-phase M
- RX-2 2400 BPS BPSK Bi-phase S
- RX-3a 4800 BPS RSM, NRZIC Bi-phase M
- RX-3b 9600 BPS RSM, NRZ (NRZ-S) and scrambler
- RX-4 (digital AFC) RX for RTX-DSP experiments

Note: Output signals of RX-4 are in-phase and quadrature components I (I) and Q (Q), which are sent to the DSP RTX immediately after analog/digital conversion with 8-bit resolution. This supports various modulation modes, depending upon the software. All other receivers provide data (D) and clock (C) signals at their outputs.

‡The AO-21 downlink can be switched to the following modes:

- Mode 1: 1200 BPS BPSK, NRZI (NRZ-S) (PACSAT and Fuji compatible)
- Mode 2: 400 BPS BPSK, Bi-phase-S
- Mode 3: 2400 BPS BPSK, Biphase-S
- Mode 4: 4800 BPS RSM, NRZIC (Biphase-M) (like 4800 bit/s uplink)
- Mode 5: 9600 BPS RSM, NRZI (NRZ-S) + Scrambler (like 9600 bit/s uplink)
- Mode 6: CW keying (only for special events)
- Mode 7: SK (F1 or F2B), eg RTTY, SSTV, fax etc. (only for special events)
- Mode 8: FM modulated by D/A signals from DSP-RISC processor (speech)

second type in which licensed astronauts operate in their spare time for fun. SAREX is now an official NASA program. "

What does the future look like?: "I hope that the powers in Washington put enough resources into space exploration. I think it is something us humans simply have to do. There are always spin-off in terms of unexpected benefits that could not

have been foreseen. We cannot always justify expenditures on space exploration by saying specifically what benefits we will reap from a program, but we usually get far more than we could have expected. When you consider TV satellites, telephone, amateur and the world-wide communications network they provide, you could not have foreseen any of this when

Goddard was trying to launch a rocket.

We plan to build a space station and we plan to go to Mars and build a space station on the Moon. I think it is pretty clear that Amateur Radio will be a part of that somehow. The SAREX program has shown the value of Amateur Radio on space missions. I think the work the Amateur community has done, including AM-

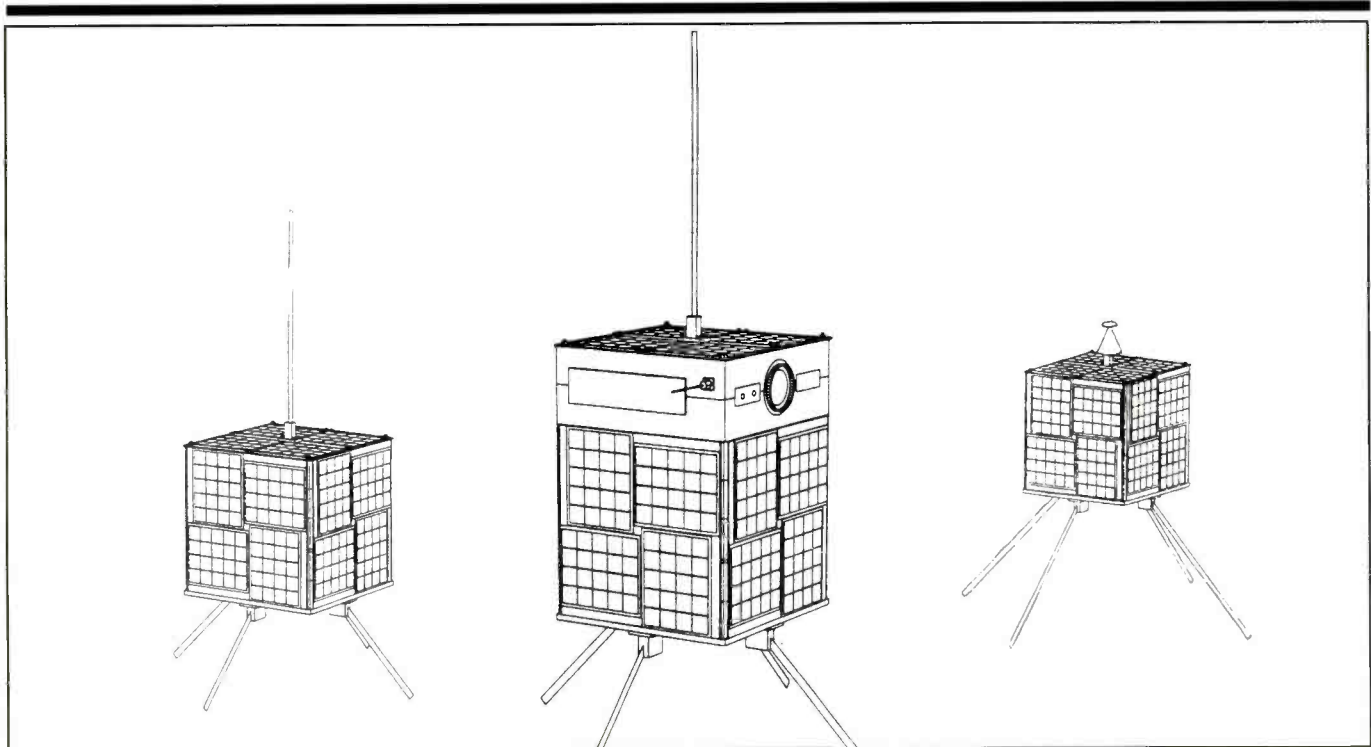

MicroSat Designs from left to right: MicroSat/PackSat, AO-16 & LO-19 (AMSAT); WeberSat, WO-18 (AMSAT-NA); and the DOVE, DO-17 (BRAMSAT).

SAT internationally, has also shown the utility of relatively small inexpensive low earth orbit satellites. A few years ago commercial interest would never have considered low earth orbit spacecraft for anything. Everything had to be geo-stationary or forget it. Now low earth orbit systems

are common again even among commercial interest. This type of system also allows you to keep the ground station equipment simple and inexpensive which is always a plus. Again this is something that amateurs demonstrated first."

I want to thank you, Bill, for taking the

time to talk with us and sharing your knowledge of the Amateur Space Program and your hopes for its future.

Write to AMSAT for membership information at 850 Sligo Ave., Silver Spring, MD 20910 or call (301) 589-6062. ■

## Amateur Radio Satellite Communications

Typical Configuration for AO-16, DO-17, WO-18, and LO-19

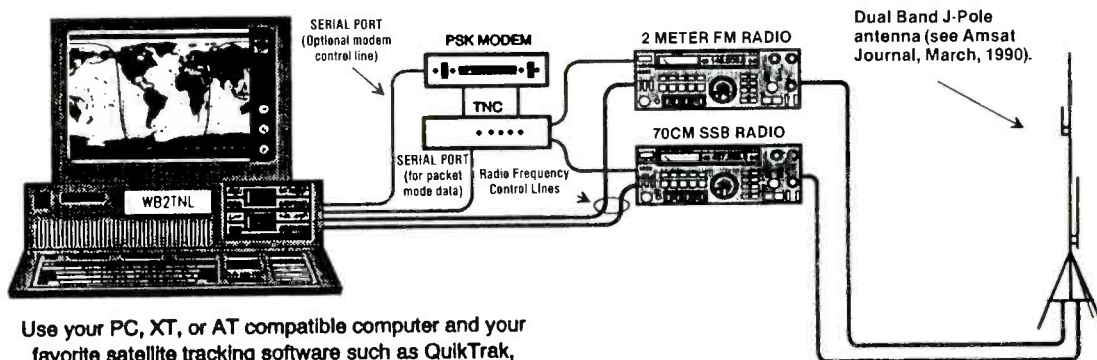

Use your PC, XT, or AT compatible computer and your favorite satellite tracking software such as QuikTrak, InstantTrack, ORBITS (all available from AMSAT).

### NOTES:

1. Use the best coax possible (9913 or hardline).
2. The computer interface to the radios provides real-time dopler correction via the Kansas City Tracker/Tuner package. Contact L.L. Grace, 41 Acadia Drive, Voorhees, NJ 08043.
3. Suitable PSK modems are the PacComm PSK-1, the TAPR PSK modem, and the G3RUH 1200bps modem.

### JOIN AMSAT

#### Benefits for you

The AMSAT Journal, QSL Bureau, help fund satellite construction, member discounts on software, publications and other items.

New Member  Renewal/Reinstatement  Member

Name \_\_\_\_\_ Call \_\_\_\_\_

Street \_\_\_\_\_

City \_\_\_\_\_

State/Prov. \_\_\_\_\_ Country \_\_\_\_\_ Zip/PC \_\_\_\_\_

Dues are \$30 US payable to AMSAT-NA, 850 Sligo Ave., Silver Spring, MD 20910 or call (301) 589-6062. Call or write for club and international rates.

VISA, MC \_\_\_\_\_

Signature \_\_\_\_\_ Expires \_\_\_\_\_



# NEW PRODUCTS

## REVIEW OF NEW AND INTERESTING PRODUCTS

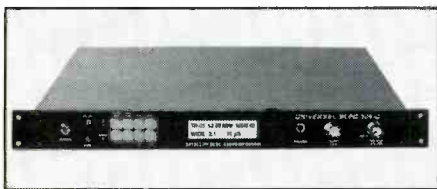

### Commercial SCPC Audio Receiver

The all-new Universal SCPC 300-C is a high-quality, microprocessor-controlled audio broadcast receiver, which incorporates every needed feature for broadcast use. There are no costly extra frequency boards needed to put you on any SCPC frequency, as the SCPC 300-C is fully frequency agile and fully transponder agile with a push of a button. No coding schemes are used for selection of its many parameters and features.

Full readout of SCPC frequency, transponder, bandwidth, de-emphasis, companding and memory channel in use are prominently displayed on easy-to-read, super-twist LCD display of two lines with 20 characters per line. All companding boards, 3:1, 2:1, 1:1 are built in and are standard features.

The SCPC 300-C has 50 non-volatile memories, which are recalled at the touch of a single button to select any SCPC channel in the set 50 to 90 MHz area. Now, one SCPC receiver can receive many SCPC channels with any transmission parameter now in use.

The new SCPC 300-C receiver has two high-quality phase lock loop synthesized frequency converters to achieve stable reception. There are two outputs, a 600 Ohm balanced line out and a 4 to 8 Ohm speaker out, plus front panel headphone monitoring jack.

The input frequency of the unit is 950-1450 MHz and can be used with any modern stable LNB or LNA with a suitable downconverter. The SCPC 300-C is fully C Band and Ku Band compatible and furnishes LNB/LNA DC voltage, plus polarity control.

Standard rack mounting of 19" wide, 10" deep, 1.75" high or a standard shelf case cabinet 17" wide, 10" deep, 1.75" high with 115 VAC, 60 cycle power requirements—other power requirements available.

Call for full information: Universal Electronics, Inc., 4555 Groves Road, Suite 13, Columbus, Ohio 43232. Phone: (614) 866-4605. FAX: (614) 866-1201.

### New GMRS Two-Channel Handheld Transceivers

New Realistic® PRS-100 Two-Channel FM Handheld Transceivers from Radio



Shack® are a convenient and affordable way for family members to stay in touch.

The radios are especially useful for family outings such as hiking, camping or ski trips.

The PRS-100 is a lightweight, portable 2-way radio manufactured to commercial-grade standards for reliability and durability. It operates on the General Mobile Radio Service Band, available for limited range non-business communication.

The transceivers provide clear transmission and reception for distances up to several miles depending on the terrain. Two channels are available so users can choose the clearest radio frequency.

Each radio comes with a rechargeable 8-hour battery, battery charger, detachable antenna, a convenient belt clip and 462.7125 and 462.6375 crystals.

A valid GMRS license from the Federal Communications Commission is required to operate the radio (an application form is included with the unit). All members of the licensee's immediate family residing in the same household are eligible to operate the radio under license.

The Realistic® PRS-100 sells for \$249.95 and is available at nearly 6,700 participating Radio Shack® stores and dealers nationwide.

## NOW! A QUALITY SATELLITE SCPC AUDIO RECEIVER

AT AN AFFORDABLE PRICE



### UNIVERSAL SCPC-100 AUDIO RECEIVER

#### SPECIFICATIONS

STABLE, MICROPROCESSOR CONTROLLED TUNING. • 50 CHANNEL MEMORY RECALL. • COMPATIBLE WITH 950-1450 BLOCK SYSTEMS. • 3 MINUTE HOOK-UP. • LARGE L.E.D. TUNING SCALE. • RECEIVES C AND KU BAND SCPC. • DOES NOT DISABLE VIDEO WHEN IN USE.

#### SERVICES ON SCPC

HUNDREDS OF QUALITY SCPC CHANNELS ON SATELLITES - SPORTS - AP - UPI - RADIO NETS - HOME TOWN SPORTS & RADIO - RACING - TALK SHOWS - CLASSICAL, ROCK & JAZZ - RADIO STATIONS - FINANCIAL NEWS AND MORE.

INTRODUCTORY PRICE \$439.<sup>00</sup> PLUS S & H

**UNIVERSAL ELECTRONICS, INC.**  
4555 GROVES RD., SUITE 13, COLUMBUS, OH 43232  
(614) 866-4605 FAX (614) 866-1201

## THE EXCITING WORLD OF RADIOTELETYPE MONITORING

**O**n Feb. 27, Secretary of State Warren Christopher met with NATO foreign ministers in Brussels, Belgium, in an unsuccessful attempt to get European members to lend logistical support to the American military operations in parachuting food and medicine into remote areas of Bosnia.

Several hours before the meeting took place, I saw a lot of RTTY traffic in French and German pertaining to this meeting being sent by NATO on 10404.5 kHz at 0709 UTC, 425/50. The text, from RFQBA in Brussels, was given the classification "NATO unclas" at the top of each page.

From time to time readers send in print-outs of RTTY#transmissions in Spanish upon which they underline the capital letters "CIA" they've found in the texts. They view the texts with suspicion but wrongly believe the letters refer to the Central Intelligence Agency.

The letters are an abbreviation of the Spanish word "compania," meaning "company." In Telexes I frequently monitor on 8001.5 and 9001.5 kHz from Bogota, Colombia, "CIA" is extensively used, along with a host of other abbreviations.

Some other abbreviations are "CIA ANTIN," for "compania antinarcoticos," "TX" for "transmitir," "RX" for "receptor," "SEPER" for "seccion personal" (personnel section), "INTEL" for "inteligencia," and "CDTE" for "comandante" (Major). "Jefe" is the Spanish word for "commanding officer."

With this in mind, if you see, "CDTE XIV CIA ANTIN," it means it's addressed to a Major in the 14th antinarcotics company, and "JEFE SEPER ANTIN" means it's from the commanding officer of the antinarcotics group's personnel section.

From St. Lys Radio, France, comes word that it closed FFT82 on 16820.5 kHz on Jan. 11, and replaced it with FFT83 on 16821.0 kHz, working ships on 16698.0 kHz.

Cruise news: 10 cruise ships have recently made their maiden voyages or will be doing so in the near future. They are Fascination (2,600 passengers) and Sensation (2,600), both of Carnival Cruise Lines; Maasdam (1,266), Ryndam (1,266), and Statendam (1,266), all of Holland America Line; Costa Romantica (1,350) of Costa Cruise Lines; Windward (1,246) of Norwegian Cruise Line; Crown Dynasty (820) of Crown Cruise Line; and Silver Cloud (314) and Silver Wind (314) of Silversea Cruises.

Ary Boender of The Netherlands notifies us that he recently monitored the net of outbanders I've written about on a couple of occasions using 6681.0 kHz for their

```

vv99+1804+0+++++
vv99+1806+0+++++
vv99+1808+0+++++
vv99+1810+0+++++
vv99+1812+0+++++
vv99+1814+06+++++
vv99+1816+0+++++
vv99+1818+0+++++
vv99+1820+0+++++
vv99+1822+0+++++
vv99+1824+0+++++
vv99+1826+0+++++
vv99+1828+0?:.9++
vv99+1830+0+++++
vv99+1832+0+++++
vv99+1834+0+++++
vv99+1836+0+++++
vv99+1838+0+++++
vv99+1840+0+++++
vv99+1842+0+++++
vv.9+1844+0+++++
vvv99+1846+0+++++
vv99+1848+0+++++
vv99+1850+0+++++
v99+1852+0+++++
vv99+1854+0+++++
vv99+1856+0+++++
vv99+1858+0+++++
vv99+1900+0+++++
vv99+1902+0+++++
vv99+1904+0+++++
vv99+1906+0+++++
vv99+1908+0+++++
vv99+1910+0+++++
vv99+1912+0+++++
vv99+1914+0+++++
vv99+1916+0+++++
    
```

*After monitoring stuff like this for months, Ary Boender of the Netherlands says he still hasn't a clue to its meaning. Can you help him? This ran at 50 baud on 5416.0 kHz, current time was indicated at UTC plus one hour.*

chatter. When I tuned in on their transmissions they were on 27538.5 kHz. They call themselves the IPRNET, or International Packet Radio Net.

Ary says he listened to them at 1020 UTC and caught numerous stations from Belgium, France, Italy, and Luxembourg. They shared propagation info, and beacon and satellite news, he reports.

In a recent transmission by CLP1, MFA, Havana, Cuba, personal telegrams in Spanish and Prensa Latina news in French and English were sent to the Cuban Embassy, Vientiane, Laos. The Laotian mission was identified with the callsign CLP-21. This callsign is listed, however, in a frequency guide as belonging to the embassy in Phonm Penh, Cambodia. Further monitoring is needed to determine which location is CLP21.

It sounds like SWED-ARQ and seems to have the characteristics of it, but none of my RTTY decoders will sync to it. It's frustrating to hear this RTTY mode on frequencies used by amateur radio operators and utility stations alike and not be able to decode it. Interestingly, those using the mode on fixed station frequencies turn out to be the military MARS stations. In other words the mode is used by amateur radio operators both in and out of the military. It was while listening in on the upper sideband voice comms of a couple of U.S. Navy MARS stations that I eventually learned what the new mode was called—PACTOR. The frequencies on which I've heard it as of this writing are 3351.3, 7076.7, 12127.5, 14072.0, 14078.5, and 14079.0 kHz.

My ham radio buddies tell me the mode was devised in Germany a few years back and has traits of both AMTOR (a.k.a. ARQ-TOR, ARQ, and Sitor-A) and Packet Radio. It's supposed to correct transmission errors in messages faster than Packet Radio does under adverse propagation. It runs at 100 and 200 baud and comes on computer software. Two companies offering PACTOR are Advanced Electronic Applications Inc. of Lynnwood, WA, and Kantronics Inc. of Lawrence, KS.

Stax of Fax Dept.: Returning to the air this past winter after a brief respite was AZG641, Buenos Aires, Argentina, on 11480 kHz, and LRO64, also Buenos Aires, on 9241.5 kHz. AZG641 sends news photos from Agence France-Presse and Noticias Argentinas, between 2100 and 2300 UTC; and LRO64 from Telam between 2300 and 0100 UTC, 60/288.

LRO84, Buenos Aires Meteo, Argentina, changed frequencies during the past winter. It moved to 18621.5 kHz from 18093.0 kHz, where it was camped for many years. ITU files list 18621.5 kHz as assigned to LRO84, Gen. Pacheco Radio, Argentina, whose transmitter was being used by the weather station. Not only did LRO84 change frequencies, it also changed its transmission schedule. I've written a letter to the station and hope they reply with details of its new operations.

On 10967.5 kHz at 0420 and 0432



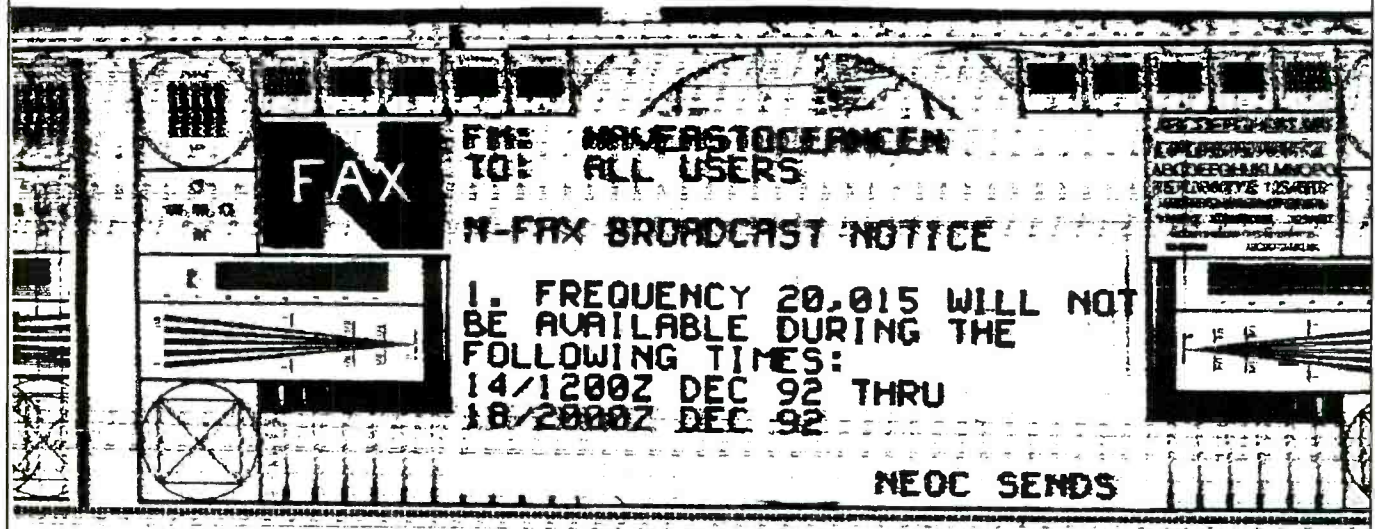
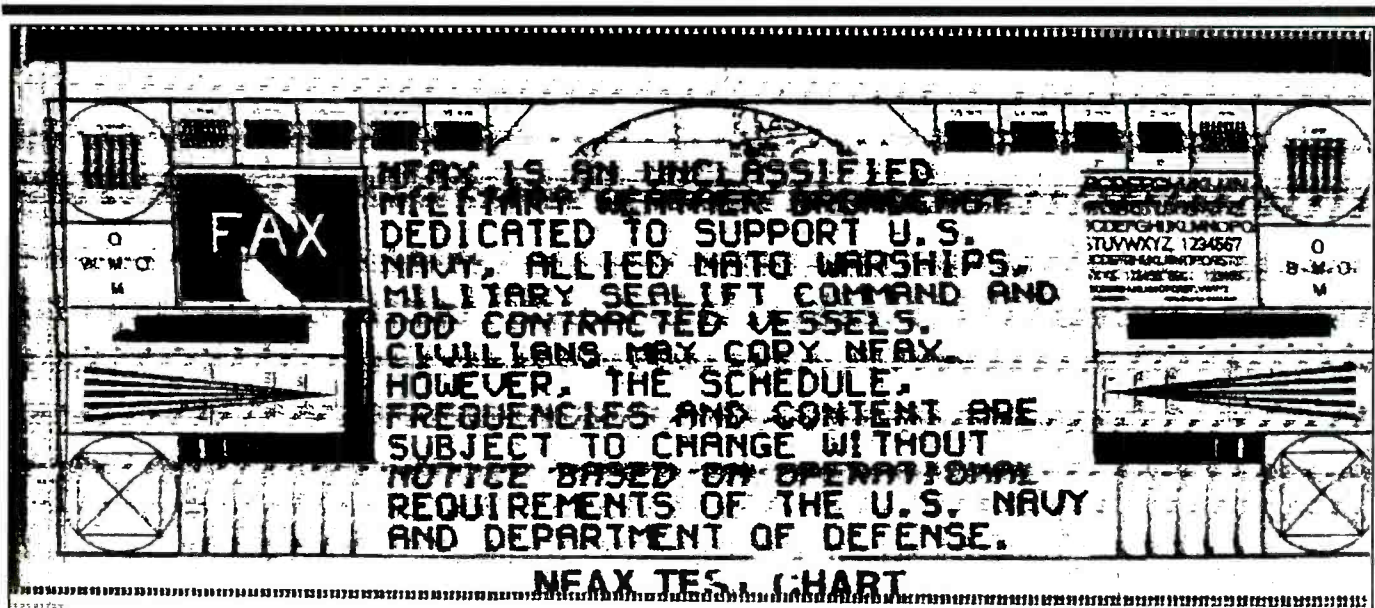

Radiofax notices sent by NAM, U.S. Navy, Norfolk, VA at 1530 UTC (top) and 1700 UTC (bottom), both on 10865 kHz, 120/576. (From Robert Margolis)

UTC, an unidentified station transmitted weather charts of NPM, Pearl Harbor Naval Base, HI, at 120/576, on a Sunday in March. The station went QRT at 0445 UTC. NPM's weather charts were also seen on 21733.0 kHz at 1810 UTC, 120/576, in February. On 11485.0 kHz, an unidentified station sent a satellite weather chart at 1801 UTC, late in February, 120/576.

Possibly fulfilling a request from a cruise ship's radio officer, WLO, Mobile Radio, AL, sent a Gulfmex surface analysis weather chart on 2574.0 kHz at 0238, 120/576. The frequency is not normally used for radiofax transmissions. A short time later, WLO provided a ship-to-shore phone patch to the ship on 2572.0 kHz USB.

Retired meteorologist William Hodge of Mississippi used his sharp eyesight to answer a recent question of mine. In February's column there was illustrated a weather chart which I monitored on 26285 kHz.

Few features were seen because of bad interference caused by single sideband voice comms on the same frequency. Bill says he saw two maps side by side showing similar state boundary lines. "I can make out two Nevadas, Utahs and Colorados," he says. Rechecking the illustration, I saw he was absolutely correct. I saw through squinting eyes those states plus two Californias in the middle of the illustrations. It became easy once I knew what to look for.

Bill says the charts appear to be a retransmission of Naveastoceancen's NMC 36/48 hour significant weather broadcast. Thanks for the solution, Bill. Now I know why my mother wanted me to eat lots of carrots when I was a little boy.

#### RTTY Intercepts

3229.2: AFS, Offutt AFB, Elkhorn, NE, w/ KAWN wx data at 0310, 75 baud. (Ed.)  
4173.0: ITDP, Agip Monfalcone (Italian cargo

ship—Ed.), w/ETA Malla msg, ARQ at 1930. (Ary Boender, NLD)

4177.5: LITO3, M/V Helen (Norwegian liquid propane gas tanker), w/a Telex at 1843, ARQ. (Boender, NLD)

4788.0: TJK, ASECNA, Douala, Cameroon, w/ coded wx at 0147. (Ed.)

5076.0: LASV2, Echo Pioneer (Norwegian dry cargo ship—Ed.), w/a msg to "Unimar Hamburg," ARQ at 1935. Not a ship freq. (Boender, NLD)

5117.5: TYE, ASECNA, Cotonou, Benin, w/ RYRY, 50 baud at 0137. (Ed.)

5233.3: AJE, USAF, Croughton AB, England, w/wx, 75 baud at 2338. (Ed.)

5345.0: RDH77, Arkhangelsk Meteo, Russia, w/RYRY, 50 baud at 2045. (Boender, NLD)

5416.0: Un-ID w/"w99+1808+0+++++" at 1708, 50 baud. Xmt'd every two mins. w/the time at UTC + one hour. (Boender, NLD)

5740.0: HZN, Jeddah Meteo, Saudi Arabia, w/coded wx at 2052, 50 baud. (Boender, NLD)

5887.9: IMB32, Rome Meteo, Italy, w/coded wx, 50 baud at 0358. (Robert Hall, RSA)

5904.1: 9GC, ASECNA, Accra, Ghana, w/RYRY at 0415, 50 baud. (Hall, RSA)

6435.0: British Royal Navy w/encrypted msgs separated by RYRY + vmgtcnjnh, 100 baud at 1625. (Boender, NLD)

6775.0: XTU, ASECNA, Ouagadougou, Burkina

**Abbreviations Used In The RTTY Column**

AA	Arabic
ARQ	SITOR mode
BC	Broadcast
EE	English
FEC	Forward Error Connection mode
FF	French
foxes	"Quick brown fox. . ." test tape
GG	German
ID	Identification/led
MFA	Ministry of Foreign Affairs
nx	News
PP	Portuguese
RYRY	"RYRY . . ." test tape
SS	Spanish
tfc	Traffic
w/	With
wx	Weather

Faso, w/wx msgs, ARQ-M2/96, channel A, at 0115. (Harold Manthey, NY)

**6835.1:** GFL22, Bracknell Meteo, England, w/coded wx, 50 baud at 0420. (Hall, RSA)

**6919.8:** RGC70, Kiev Meteo, Ukraine, w/coded wx at 0307. 50 baud. (Ed.)

**6972.0:** YOG58, Rompress, Bucharest, Romania, w/nx at 1655, 50 baud. (Boender, NLD)

**7498.9:** OZU25, MFA, Copenhagen, Denmark, w/encrypted msgs at 1640, Twinplex/100. (Boender, NLD)

**7685.2:** NNN0ASG, USN MARS, Great Lakes Naval Training Center, North Chicago, IL, w/tfc for region 4 stas at 1922. ARQ. (Ed.)

**7715.0:** RCU71, Novosibirsk Meteo, Russia, w/coded wx at 1230, 50 baud. (Ed.)

**7863.0:** BJZ21, Wuhan Meteo, China, w/coded wx, 75 baud at 1225. (Ed.)

**8001.5 & 9001.5:** Colombian drug busting ARQ t/c in SS runs almost daily after 0000. (Ed.)

**8020.0:** HMF85, KCNA, Jungsan, North Korea, w/nx in EE, 50 baud at 1820. (Boender, NLD)

**8033.5:** Un-ID Romanian diplo w/encryption at 0658. ROU-FEC/164.5. (Ed.)

**8098.0:** Un-ID w/ARQ msgs in EE at 1600. Gave selcal of 81111. (Ed.)

**8122.8:** Un-ID w/RYRY + "vmgtcnjhb" between encrypted msgs, 75 baud at 2150. (Ed.)

**8284.5:** Un-ID w/an unknown synchronous TTY mode at 96 baud at 0431. (Ed.)

**8420.0:** FFT41, St. Lys R., France, w/navareas & wx in FF at 0912. FEC. (Ed.)

**8420.6:** 9VG78, Singapore Radio w/a t/c list, FEC at 2138. (Hall, RSA)

**8421.0:** OXZ, Lyngby R., Denmark, w/a t/c list, ARQ at 0730. (Ed.)

**8432.5:** WOM, Fort Lauderdale R., FL, w/a radiotelephone t/c list in FEC at 0932. (Ed.)

**8454.0:** UJY, Kaliningrad R., Russia, w/a t/c list, 50 baud at 1530. (Boender, NLD)

**8493.0:** Un-ID w/encrypted msgs separated by RYRY + "vmgtcnjhb", 100 baud at 0145. (Ed.) Same at 1538. (Boender, NLD)

**8500.3:** VTH, Bombay Navrad, India, w/RYRY + "RBSL BNR" ID, & 4 A/N grps, 50 baud at 2116. (Hall, RSA)

**8672.7:** MTO, Rosyth Navrad, Scotland, w/availability tape at 0853, 75 baud. At 0859 appeared, "0570859 de MTO LF state A2/8/9 D1 H3 I11 O4 W1." (Ed.)

**9153.8:** Un-ID w/a brief msg that was somewhat garbled. It ended w/"mata nouchi hodo," which might be JJ, Was ARQ at 1425. (Ed.)

**10150.2:** SUA246, MENA, Cairo, Egypt, w/nx in AA, 75 baud at 1751. (Hall, RSA)

**10298.8:** HSW62, Bangkok Meteo, Thailand, w/coded wx, 50 baud at 1916. (Hall, RSA)

**10385.7:** BAA21, Tianjin Meteo, China, w/coded wx at 1913, 50 baud. (Hall, RSA)

**10407.0:** 6VY56, ASECNA, Dakar, Senegal, w/RYRY at 0743, foll by wx at 0800, 50 baud. (Ed.)

**10416.5:** ETS, Addis Ababa Air, Ethiopia, running its RYRY test tape backward (STE STE STE RYRYR...), 0408-0459, before catching the error.

**NATIONAL WEATHER SERVICE HONOLULU - RADIO FACSIMILE SCHEDULE - KVM70**

CHRT DESCRIPTION	AREA	UTC TIME OF TRANSMISSION	KVM70 RADIO FREQUENCIES
TEST - ID - SCHEDULE	A	2333	0639-0725 UTC 10900 / 18135.0 kHz
SIGNIFICANT CLOUD FEATURES	A	2347	1138-1424 UTC 9828 / 1080.0 kHz
SATELLITE WASER	DISK	2607	1733-1622 UTC 10900 / 18135.0 kHz
PACIFIC SURFACE ANALYSIS	B	0047	1833-1202 UTC 10900 / 18135.0 kHz
TROPICAL SURFACE ANALYSIS	C	0207	
24 HR SURFACE FORECAST	D	0308	
48 HR SURFACE FORECAST	D	0508	
24 HR WIND/STREAM FORECAST	E	0707	
48 HR WIND/STREAM FORECAST	E	0907	
OPEN			
TEST - D - SCHEDULE	A	0400	
SIGNIFICANT CLOUD FEATURES	A	0447	
SATELLITE WASER	DISK	0607	
PACIFIC SURFACE ANALYSIS	B	0807	
TROPICAL SURFACE ANALYSIS	C	1007	
24 HR SURFACE FORECAST	D	1207	
48 HR SURFACE FORECAST	D	1407	
24 HR OCEAN WIND/WAVE HT POST	F	1608	
48 HR OCEAN WIND/WAVE HT POST	F	1808	
72 HR OCEAN WIND/WAVE HT POST	F	2008	
OPEN			
TEST - E - SCHEDULE	A	1733	
SIGNIFICANT CLOUD FEATURES	A	1747	
SATELLITE WASER	DISK	1907	
PACIFIC SURFACE ANALYSIS	B	2107	
TROPICAL SURFACE ANALYSIS	C	2307	
24 HR SURFACE FORECAST	D	0108	
OCEAN SURFACE TEMPERATURE	GA	1928	

**TO COMMENT ON THIS BROADCAST PLEASE WRITE TO:**  
**NWS - WSFO - KVM70**  
**POB 28678**  
**HONOLULU HI 96820**  
**Phone: 808/541-1698**  
**VISIT US WHEN IN PORT**



*KVM70, Honolulu Meteo, Hawaii, recently redesigned the radiofax schedule it broadcasts on shortwave radio. The one at the top is from early 1992 and the other appeared earlier this year.*

0507: "final t/c ch for 24/02/93" & a few aviation wx msgs. Was 50 baud. (Ed.)

**10523.2:** HMF45, KCNA, Bosong, North Korea, w/nx in FF, 50 baud at 1330. (Ed.)

**10600.0:** XVN37, VNA, Hanoi, Vietnam, w/nx in FF, 50 baud at 1424. (Ed.)

**10753.8:** RPFN, Monsanto Navrad, Portugal, w/5L msg, 75 baud at 0748. (Ed.)

**10871.3:** AJE, USAF, Croughton AB, England,

w/EGWR wx data, 75 baud at 0803. (Ed.)

**10893.9:** Telam, Buenos Aires, Argentina, w/nx in SS at 2040, 50 baud. (Hall, RSA)

**10960.0:** 3MA28, CNA, Taipei, Taiwan, w/nx in EE at 1340, 50 baud. (Ed.)

**11063.0:** LZU2, Sofia Meteo, Bulgaria, w/coded wx at 1653, 50 baud. (Boender, NLD)

**11078.0:** CCX, un-ID of the Chilean Navy, w/5L grps at 0015, foll by its ID at 0017, 50 baud. (Manthey,



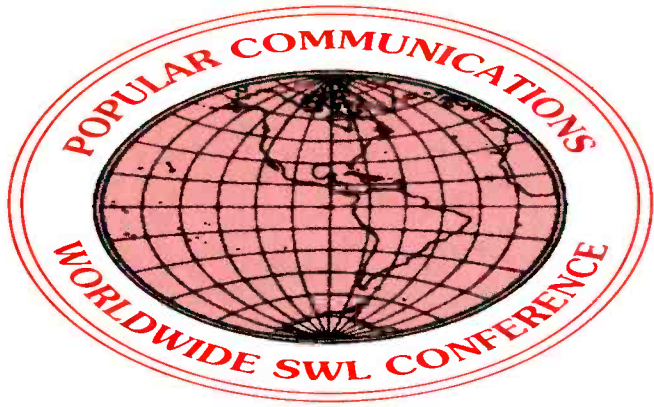

# Popular Communications

## Worldwide SWL Conference! October 2-3, 1993

\* Meet major SW broadcasters

\* EXPERT Speakers on Current topics include:

- ★ Antenna Construction Tips and Techniques with Bill Price
- ★ Buying a Receiver by Dick Robinson of Electronic Equipment Bank
- ★ PopComm "Listening Post" get-together with PopComm columnist and SW authority Gerry Dexter
- ★ The Future of SW Broadcasting, with world-renowned shortwave and propagation authority George Jacobs
- ★ How to QSL What You Hear by columnist Gerry Dexter
- ★ Pirate Radio – Hearing the Action with Pat Murphy of WNIS Radio
- ★ SWLing – What You Need To Know with shortwave expert, Dr. Harold Cones
- ★ Worldwide NASA and Satellite Comms with PopComm columnist and NASA authority Don Dickerson
- ★ SW Broadcasting – It's Two-Way Communication with noted international broadcaster Ian McFarland

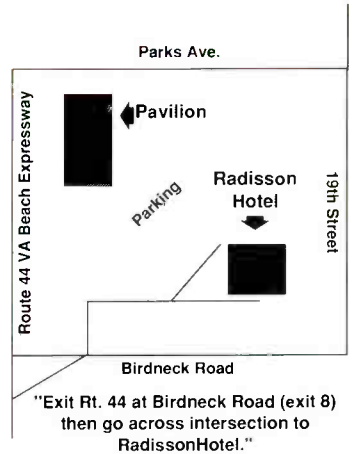

### PLUS – Speakers from the VOA, BBC and more!!!

KEYNOTE SPEAKER, Roy Neal, K6DUE, will talk about SAREX (Shuttle Amateur Radio Experiment) and Tuning the Space Shuttle Comms. He's the Chairman of SAREX, for ARRL-AMSAT and former NBC News Correspondent.

Dozens of manufacturers and dealers of SWL and amateur radio equipment will be on hand demonstrating their equipment and ready to answer your questions on the spot -- including -- Kenwood, ICOM, Yaesu, Alinco and more!

The SWL Conference will be held in conjunction with the **18th Annual Virginia Beach Hamfest and Computer Fair** (the areas LARGEST hamfest and computer exhibit). The first Popular Communications Worldwide SWL Conference, held at the Radisson Hotel, Virginia Beach, Virginia has something for everyone! Make plans NOW to be there. As part of the one-time \$25 admission charge, on October 3 you also get a tour of nearby Norfolk Naval Base that includes a visit to a ship and Naval Base waterfront.

**Make Plans Now to attend both days – October 2 - 3, 1993 at the Virginia Beach Pavilion; minutes from the beach, Navy bases and historic sites!**

**Radisson Hotel is across parking lot from Pavilion. You can walk between both!**

**"Talk-in frequency 146.970 MHz."**

**To acquire room reservations at the Radisson Hotel Virginia Beach call 1-800-333-3333 and ask for Virginia Beach Hamfest rates.**

**Registration in the Radisson Hotel, Friday, October 1 from 2 to 8 p.m.**

Yes, please reserve \_\_\_\_\_ tickets at \$25 each.

Pick up tickets and info. pack at the Radisson Hotel on October 1 between 2 and 8 p.m.



Name \_\_\_\_\_ Call \_\_\_\_\_

Address \_\_\_\_\_

City \_\_\_\_\_ State \_\_\_\_\_ Zip \_\_\_\_\_

Check     Money Order     MasterCard     VISA     AMEX     Discover

exp. date \_\_\_\_\_

--	--	--	--

Mail your order to: **Poplular Communications**  
76 North Broadway, Hicksville, NY 11801 Telephone 516 681-2922; FAX 516 681-2926

NY)

**11133.0:** BZG41. Xinhua, Yuryumqi, China, w/nx in FF. 50 baud at 1514. (Boender, NLD)

**11331.5:** "Golf Siete Zulu" w/very garbled t/c in SS to "Quebec Uno Echo" at 0053. 50 baud. (Ed.)

**11470.0:** RNK33. Moscow Meteo. Russia, w/coded wx at 1235. 50 baud. (Ed.)

**11476.0:** HMF52. KCNA. Bosong, North Korea. w/nx in EE at 2319. 50 baud. Usually seen with fax news photos at this time. but they were delayed until 2339 on this day. (Ed.)

**11541.7:** RFLI. French Navy, Fort de France, Martinique. w/"control de voie" to Papeete, Tahiti at 1352. ARQ-E3/96. (Ed.)

**12096.0:** XVH56. Hanoi Meteo. Vietnam, w/coded wx, 50 baud at 0052. (Manthey, NY)

**12204.8:** NBA. USN. Balboa. Panama. w/"Exercise Flame River 93" t/c, 75 baud at 1621. (Ed.)

**12223.5:** RPFRRK, Portuguese Air Force. Porto Santo, Madeira, w/msgs. "confidencial" t/c & 5L grps to RPTTA. "Basequatro." (PAF. Ponta Delgada, Azores). at 1954. ARQ. (Ed.)

**12227.3:** AFS. Offutt AFB, Elkhorn, NE, w/KAWN wx data at 1600. 75 baud. (Ed.)

**12477.5:** ZSUY. S.A. Waterberg (South African cargo ship). w/wx obs to Portishead Radio, ARQ at 1843. (Ed.)

**12484.0:** WGWA. Omi Willamette (USA tanker), w/AMVER msg. ARQ at 2024. (Ed.)

**12490.0:** NRLW. USNS Hayes (T-AGOR-16), oceanographic research ship. w/ARQ t/c at 2146. (Ed.)

**12580.0:** GKE5. Portishead R., England. w/wx forecasts issued by Bracknell Meteo. FEC at 2130. (Ed.)

**13365.9:** CSY46. Santa Maria Air. Azores, w/aviation wx, 50 baud at 0600. (Hall, RSA)

**13416.8:** CCS, Santiago Navrad, Chile. w/RYRY & SGSG, 1202-1206. foll at 1208 w/op msg. 75 baud. (Ed.)

**13440.0:** YZT5, Tanjug. Belgrade. Yugoslavia, w/RYRY & nx in EE. 50 baud at 0604. (Hall, RSA)

**13530.0:** RVW53, Moscow Meteo. Russia, w/coded wx at 1445. 50 baud. (Ed.)

**13542.0:** ZRO3. Pretoria Meteo, RSA. w/coded wx, 75 baud at 0517. (Hall, RSA)

**13801.4:** RPTTA w/msgs in PP & 5L grps to RPFRRJ & RPFRRW. ARQ at 1622. (Manthey, NY) RPTTA is Portuguese Air Force, Ponta Delgada, Azores—Ed.

**14481.7:** RFFA, Mindlefense. Paris. France. w/5L msg. & "non protege" t/c. at 1933, ARQ-E3/48. (Ed.)

**14452.0:** HMF57. KCNA, Jungsan, North Korea, w/nx in FF at 1400. 50 baud. (Ed.)

**14454.8:** Un-ID w/coded wx. 50 baud at 1250. (Ed.)

**14497.8:** CSY66, Santa Maria Air, Azores, w/aviation wx, 50 baud at 0746. (Hall, RSA)

**14518.0:** OEC. MFA. Vienna, Austria, w/5L "zirkulars" to Tel Aviv. Israel. at 1302. & nx in GG to Delhi, India, at 1324, ARQ-S5/96. (Ed.)

**14785.0:** MEA. Delhi, India. w/nx in EE at 1455, 50 baud. (Manthey, NY)

**14880.3:** JMG4. Tokyo Meteo. Japan, w/coded wx. 50 baud at 1611. (Hall, RSA)

**14937.5:** Un-ID w/RYRY, ARQ-E/96 at 0625. (Hall, RSA)

**14941.7:** FJY3, Dumont d'Urville, Antarctica, w/msgs in FF & EE, ARQ-E3/96 at 0803. (Ed.)

**14943.7:** MFA, Cairo. Egypt. w/t/c in AA, ARQ at 0618. (Hall, RSA)

**16074.0:** MFA. Oslo, Norway, w/t/c in Norwegian, SWED-ARQ at 1358. (Ed.)

**16228.0:** "YBU" w/RYRY & coded msg. at 1400, 75 baud. ("Bunky," IL)

**16332.0:** "V5G," MFA, Bucharest, Romania, w/circulars in Romanian, ROU-FEC/164.5 at 1353. (Ed.)

**16701.0:** JYGA. Jordan 1 (Jordanian cargo ship). w/Telexes to Amman, ARQ at 1750. (Ed.)

**16710.0:** P3HR2, Belgrano (Cypriot cargo ship), w/msg that a stowaway was found aboard ship. ARQ at 2106. (Ed.)

**16813.0:** KPH, San Francisco R., CA, w/t/c list foll by ad for the nx/info services of KPH & WCC. ARQ at 1502. Both coastalstas are owned by MCI. (Ed.)

**16814.5:** HEC17. Berne R., Switzerland. w/msgs. ARQ at 1450. (Ed.)

**16822.5:** HPP, Panama R., Panama, w/sailing

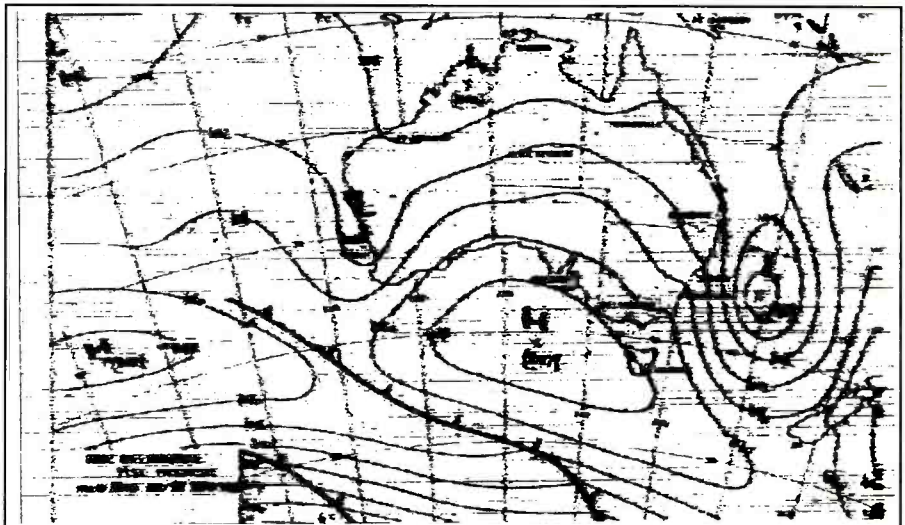



**BUREAU OF METEOROLOGY  
AUSTRALIA**

## QSL VERIFICATION CARD

**We have pleasure in confirming your reception report**

DATE	TIME (UTC)	FREQUENCY	
<b>11-11-92</b>	<b>15-15</b>	<b>13920</b>	
CALL SIGN	TX LOCATION	POWER	SERVICE
<b>AXM35</b>	<b>Canberra</b>	<b>5kW</b>	<b>Faxsimile</b>
AXM Canberra 35° 14'S/149° 07'E		AXI Darwin 12° 28'S/130° 57'E	

ANGUS LOW

A copy of a weather chart (top) was sent to AXM35, Canberra Meteo Australia, by the RTTY column editor, along with a reception report. In return, AXM35 sent an QSL card printed on green stock (bottom).

sked for 3EIN9. Chiquita Tower (Panamanian cargo ship), ARQ at 1444. (Ed.)

**16831.5:** FFT83, St. Lys R., France. w/Telex t/c at 1525. ARQ. (Ed.)

**16836.0:** AFS, Norddeich R., Germany, w/a Telex to the German ferry "Natal." ARQ at 1430. (Ed.)

**16838.5:** 9AR, Rijeka R., Croatia, w/msgs to YTTY, Kamnik (Yugoslav cargo ship), ARQ at 1414. (Ed.)

**16870.0:** KMI, Dixon R., CA, w/t/c list, FEC at 1556. (Ed.)

**17051.8:** Un-ID w/encrypted msg. separated by RYRY & "vmgtcnjhb," 100 baud at 1704. (Ed.)

**17444.8:** AFS, Offutt AFB, Elkhorn, NE. w/KAWN wx data, 75 baud at 1548. (Ed.)

**17445.0:** 5YE, Nairobi Meteo. Kenya, w/ID & coded wx, 100 baud at 2125. (Manthey, NY)

**17459.0:** OEC, MFA, Vienna, Austria, w/nx in GG + a "zirkular" w/5L grps to Paris. + 2 Telexes to Moscow, ARQ-S6/96 at 1322. (Ed.)

**17471.8:** RPFN, Monsanto Navrad, Portugal, w/RYRY. SGSG. foxes. & 10 count to RPTI. foll by op msg. & encryption. 75 baud at 1503. (Ed.)

**18128.0:** "GMN" w/RYRY & a 5F msg. 75 baud at 1650. ("Bunky," IL)

**18196.0:** "KRN" w/RYRY & a 5L msg. at 1735, 75 baud. ("Bunky," IL)

**18230.0:** GFL25, Bracknell Meteo. England,

w/coded wx. 50 baud at 1725. ("Bunky," IL)

**18242.2:** ZRO4, Pretoria Meteo, RSA. w/coded wx, 50 baud at 0708. (Hall, RSA)

**18291.5:** German Emb., Accra, Ghana, w/t/c in GG & crypto to Bonn, ARQ-E/96 at 1144. (Hall, RSA)

**18450.0:** Un-ID w/5L grps, 50 baud at 1444. (Ed.)

**18526.0:** ORI37, RTT, Brussels, Belgium, w/msgs in FF. ARQ at 1435. (Ed.)

**18547.0:** "V5G," MFA, Bucharest, Romania, w/encryption at 1530, ROU-FEC/164.5. (Ed.)

**18571.4:** 2 Un-ID stas working each other in ARQ at 1354. One sta. had a very weak sig that couldn't be decoded. Stronger sta. told the other in FF to reorient his antenna because of bad propagation. (Ed.)

**18592.5:** CLP12, Cuban Emb., Lima, Peru, w/t/c on a Sunday, 50 baud at 1610. (Ed.)

**18597.5:** EAE220, MFA, Madrid, Spain, w/encryption or service msg. to Managua, Nicaragua, at 1727. ARQ. (Ed.)

**18648.5:** SOT265B, PAP, Warsaw, Poland, w/nx in Polish at 1803. FEC. (Ed.)

**18702.3:** DFS70, PIAB, Bonames, Germany, w/nx in GG. FEC-A/96 at 1449. (Ed.)

**18746.7:** Un-ID idling in ARQ, 1651-1659. (Ed.)

**18760.0:** "P6Z," MFA, Paris, France, w/5 pages of 5L grps, FEC-A/192 at 1810. (Ed.)

**18762.0:** "V5G," MFA, Bucharest, Romania,



w/nx in Romanian at 1807, ROU-FEC/164.5. (Ed.)

**18810.0:** Swedish Emb., Buenos Aires, Argentina, w/lengthy text re Argentine economy, SWED-ARQ at 1237. (Hall, RSA)

**18845.0:** Un-ID w/"SPK 2/343" + RYRY, foll by 2 5F msg. Was 50 baud at 1615. (Ed.)

**18886.7:** CLP1, MFA, Havana, Cuba, w/encryption & nx in EE & SS to African & Asian Embs, 50 baud at 1912. (Ed.)

**18972.0:** "DFZG," MFA, Belgrade, Yugoslavia, w/nx in SC at 1520, 75 baud. ("Bunky," IL)

**19190.0:** Un-ID French diplo idling 1609-1614. ARQ6-90/200. (Ed.)

**19350.4:** Un-ID w/crypto after RYRY, 75 baud at 1245. (Hall, RSA)

**19418.5:** RFFA, Mindefense, Paris, France, w/"non protege" msg & 5L msg to Cayenne, French Guiana, ARQ-E/96 at 1640. (Ed.)

**19576.0:** ORI59, RTT, Brussels, Belgium, w/tfc, ARQ-M2/96, channel A, at 1408. (Ed.)

**19640.6:** MFA, Rome, Italy, w/5L grps to Riyadh, Saudi Arabia, ARQ at 0610. (Hall, RSA)

**19845.1:** CLP1, MFA, Havana, Cuba, w/tfc in SS & 5L grps. 50 baud at 0635. (Hall, RSA)

**19931.7:** French Emb., Fort de France, Martinique, w/sev. 5L msg at 1958. ARQ6-90/200. (Ed.)

**20101.7:** MFA, Cairo, Egypt, w/tfc in AA. ARQ at 1348. (Ed.)

**20132.0:** DFZG, MFA, Belgrade, Yugoslavia, w/Tanjung nx in EE, 75 baud at 1545. ("Bunky," IL)

**20156.5:** Un-ID w/msgs in FF at 1458. ARQ. (Ed.)

**20157.2:** HCE24, Quito, Ecuador, & PTO2, Brasilia, Brazil, working each other in SS, FEC & 45 baud, at 1545. (Ed.)

**20243.5:** PWS, Salvador Navrad, Brazil, w/"exercicio" msg to PWX, Brasilia Navrad, Brazil, 1353-1400, 75 baud. Msgs marked "fm ERMSAL to ERMBRA." (Ed.)

**20326.5:** RFFA, Mindefense, Paris, France, w/"non protege" msg. ARQ-E/96 at 1610. (Ed.)

**20342.0:** Un-ID w/what appeared to be nx in an un-ID lang., 75 baud at 1330. Saw "NA" & "PO" often in text. ("Bunky," IL) One possibility is "V5G," MFA, Bucharest, Romania. My database shows "VB5G" on sev. freqs around this one in ROU-FEC mode, but I've seen "V5G" use 75 baud RTTY— Ed.

**20401.8:** YWMI, Maracaibo Navrad, Venezuela, w/unclas IANTN msg to CCS, 75 baud, 1429-1445. (Ed.)

**20584.0:** Salini Costruttori SPA, Rome, Italy, w/msgs. ARQ at 1505. (Ed.)

**20758.0:** RFLIG, French Marines, Cayenne, French Guiana, w/"non protege" msg & 5L msg to Paris, ARQ-E/96 at 1527. (Ed.)

**21831.4:** Un-ID w/30 character per line encrypted msg, ARQ at 1625. ("Bunky," IL) It's either MFA, Madrid, Spain, or one of its embs— Ed.

**21856.0:** Un-ID French diplo idling, 1526-1529, then w/a s/off msg in FF, ARQ6-90/200. (Ed.)

**22289.0:** LXCR, Transport Maas (Luxembourg containers ship), w/Telex t/c at 1737, ARQ. (Ed.)

**22353.0:** Y5EN, Stassfurt (German bulk carrier), w/nx in GG at 1715 & 1915, FEC. (Ed.)

**22378.0:** FFT91, St. Lys R., France, w/plaintext wx in FF at 1810, FEC. (Ed.)

**22387.5:** SVT7, Athens R., Greece, w/kg M/V Angelic Faith, ARQ at 1425. (Boender, NLD)

**22394.5:** LPD88, Gen. Pacheco R., Argentina, w/tfc list at 1055, FEC. (Ed.)

**22407.5:** UAT, Moscow R., Russia, w/kg M/V Patia Zelenko at 1418, ARQ. (Boender, NLD)

**22425.5:** WOM, Fort Lauderdale R., FL, w/tfc list & service info, FEC at 1037. (Ed.)

**22862.0:** CLP1, MFA, Havana, Cuba, w/personal telegrams in SS to CLP21, Vientiane, Laos, 50 baud at 1656. (Ed.)

**23006.7:** MFA, Cairo, Egypt, w/Telexes in AA, ARQ at 1435. (Ed.)

**23045.2:** CLP1, MFA, Havana, Cuba, w/RYRY w/o ID foll by a circular w/5F grps. 50 baud at 1428. On another day, at 1434, sent nx in FF. (Ed.)

**23052.5:** CLP1, MFA, Havana, Cuba, w/nx & telegrams to CLP4, 50 baud at 1440. T/c included circular 251 (nx in FF), the same circular sent 15 min. earlier on 23085.3 kHz. (Ed.)

**23085.3:** CLP1, MFA, Havana, Cuba, w/5F msg to various embs + nx in FF to embs that are in

countries that were former French colonies. Was 50 baud at 1420. (Ed.)

**23116.7:** MFA, Cairo, Egypt, w/Telexes in AA & 5L grps to Conakry, Guinea, ARQ at 1408. (Ed.)

**23251.7:** MFA, Cairo, Egypt, w/a test tape in FEC at 1513, going to ARQ at 1514 w/a 5L msg & a Telex in AA to numerous embs. (Ed.)

**23322.5:** Un-ID French diplo idling 1331-1354, then w/"to PO rcvd 103 109 qru 73s." ARQ6-90/200. (Ed.)

**23355.0:** CLP18, Cuban Emb., Dar-es-Salaam, Tanzania, w/RYRY & t/c, 50 baud at 1800. ("Bunky," IL)

**23357.6:** Un-ID w/some t/c in EE, ARQ at 1150. (Hall, RSA)

**23366.1:** Un-ID w/ARQ pulses only at 1215. (Hall, RSA) This might be HGX21, MFA, Budapest, Hungary, in DUP-ARQ— Ed.

**23392.0:** LOL, Buenos Aires Navrad, Argentina, w/ice obs msg to NBA for relay to RULKSKD, Navpolar Oceanen. Suitland, MD. Was 75 baud at 1628. (Ed.)

**23556.0:** IPG20, MFA, Rome, Italy, w/5L grps & msg in II, ARQ-E/96 at 1527. (Ed.)

**23561.7:** PCW1, MFA, The Hague, NLD, w/msgs in Dutch. ARQ at 1640. (Ed.)

**23691.2:** DGX69, PIAB, Elmshorn, Germany, w/nx in GG at 1216, FEC-A/96. (Hall, RSA)

**23715.3:** CLP1, MFA, Havana, Cuba, w/5F msg to Nigeria, 50 baud at 1517. (Ed.)

**23976.7:** Egyptian Emb., Accra, Ghana, w/tfc in AA to MFA, Cairo, ARQ at 0805. (Hall, RSA)

**24021.7:** Un-ID Egyptian diplo w/a msg in AA, ARQ at 1440. (Ed.)

**24871.8:** RFHJ, French Navy, Papeete, Tahiti, w/"controle de voie" to RFLI, ARQ-E3/96 at 1819. (Ed.)

**25271.5:** ISX25, ANSA, Rome, Italy, w/nx in FF at 1459, 50 baud. (Ed.)

**25420.7:** Un-ID idling 1240-1411, ARQ-E/96, then to CW for s/off. (Ed.)

**25422.5:** German Emb., Luanda, Angola, w/tfc in GG to MFA, Bonn, ARQ-E/96 at 1108. (Hall, RSA)

## To Order Back Issues

Send \$3.50 Per Issue  
(Check, Money Order,  
Mastercard, VISA, and AMEX).

Send All  
Correspondence To:

CQ Communications  
76 North Broadway  
Hicksville, NY 11801

Or Call  
516-681-2922  
FAX 516-681-2926

ORDER YOUR  
BACK ISSUES  
TODAY!

## HR Bookstore

### New Books For Spring Listening!



8th Edition

"Top Secret"

### Registry US Government Frequencies

Latest edition from noted PopComm editor Tom Kneitel, K2AES. Contains all the latest frequencies, call signs and station data. This is one of the most complete frequency data books available to the radio listener. ©1993 268 pages

CRB-TS8 Softbound \$21.95



### 1993 World Radio

### TV Handbook Fully revised

One of our most popular books for the SWL. Fully revised with all the latest call signs, frequencies and station information. Invaluable aid to have while scanning the shortwave bands. ©1993 edition over 600 pages!

WRTV93 Softbound \$19.95

### 1993 WRTH Buyer's Guide

This new book is full of valuable information for all SWL's and hams alike. Radios are fully tested and performance reports given. Also gives you a price versus performance evaluation. © 1993 over 500 pages

WRBG93 Softbound \$19.95

Buy'em both Save \$5

WRTB \$34.90

Shipping and handling (per order): \$4.00 by US Mail.  
\$5 by UPS ground. Foreign shipping minimum rate \$7.  
Please include sufficient funds

Call for Free Catalog   
 (800) 457-7373

(603) 899-6957

(603) 899-6826 FAX

HR Bookstore

PO Box 209

Rindge, NH 03461 -0209



# LISTENING POST

BY GERRY L. DEXTER

## WHAT'S HAPPENING: INTERNATIONAL SHORTWAVE BROADCASTING BANDS

Three years ago the idea that Radio Moscow facilities would serve as a Voice of America relay would have been laughable—looked upon as the ravings of someone whose brain had a loose antenna connection. Well, guess what, gang? You can now pick up VOA broadcasts via transmitters at three different Russian sites. The current VOA/Russia schedule shows transmissions at 1400 to 1500 on 5945 in Chinese, via Irkutsk; 1400 to 1600 in Chinese from Novosibirsk on 5925; 2130 to 2200 in Korean on 7300 via Petropavlovsk-Kamchatsky and 2200 to 2300 in Chinese on 5925 via Irkutsk. The schedule is not optimum for summertime reception in North America but we should have some good shots at this come fall and winter.

Incidentally, anyone having problems getting a QSL out of the Voice of America can probably get a quicker response by writing to Janice Davis, VOA/B/BE, Room 1547, 330 Independence Avenue SW, Washington DC 20547. Or try care of John Vodenik, P.O. Box 227, Mason, OH 45040. He's a transmitter engineer at the VOA Bethany site.

Slovak Radio's foreign service has settled on a schedule of 0130 to 0200 on 5930 and 7345, 1400 to 1500 on 6055, 7345 and 9505 and 1900 to 1930 on 9580. Reports go to 81290 Bratislava, Slovakia. At other times these frequencies are used by the Czech Republic Radio, which is now calling itself Radio Prague.

The long-running "Austrian Shortwave Panorama" program on Radio Austria International has been discontinued, at least temporarily. The program was removed from Radio Austria International's schedule after the retirement of David Herges, the fellow who presented the program. If you want to see the show continue you should write to Paul Lendvai, Radio Austria International, A1136, Vienna, Austria.

The former Soviet Republic of Azerbaijan now has its own foreign service although, as presently scheduled, it's only intended for Europe, at 1700 to 1800 on 6175. The full name is Radio Dada Gorgud, the Voice of Azerbaijan.

One very interesting appearance on the shortwave bands is Radio Raju (Hope) in Somalia. The station calls itself the Voice of the United Task Force and was heard in Europe running tests on 9540 to 1200. This is one of those shortwave situations which appear to be very temporary so the station may be gone by now.

Radio Miami International has experienced further delays in getting its own transmitter on the air. The station has to move its antenna to prevent interference to a local mediumwave station and that, in



R.C. Watts of Louisville, KY took some photos on a visit to China Radio International. This building houses CRI, China People's Broadcasting and the Ministry of Radio, Film and Television.

turn, meant getting a new lease arranged for the land. As of then RMI did not yet have its antenna installed or tested, nor had the transmitter building been constructed, although the transmitter is sitting in a warehouse, ready to go.

French Guiana's RFO: Cayenne is reported to be active again. It was noted, in

French, around 1000 on 5055.

Christopher Holt in Massachusetts provides a US address for the Voice of Free China: P.O. Box 192793, San Francisco, CA 04119-2793, and notes the current schedule to North America is 0200 to 0400 on 5950, 9680 and 15345 and 0700 to 0800 on 5950.



CRI's Studio 13, where a taped program in Chinese is aired. (Thanks R.C. Watts)



MAIL NOTES: David Gasque of Orangeburg, South Carolina checks in after an absence and, in so doing, solves the mystery of the unidentified DX'er shown in last December's column. David says he wonders how many people gave up the hobby after seeing his picture!

Stephen C. Behrendt of Lincoln, Nebraska, also returns after being silent for a time. Steve wonders about the "non-QSL" replies he's getting from Mexican stations Radio Mil and Radio Educacion. He says he's getting form letters, schedules, thanks and such but "nothing resembling a QSL." It's hard to say without seeing the replies, Steve, but it's possible that what you're receiving is what the station intends as a QSL. Not all stations have QSL cards as such and sometimes even the letters they send aren't very specific about verifying reception.

Clark R. Badie of Glendale, Arizona is returning to the hobby after many years away. He's wondering whether Radio Iraq International is responding to reception reports. We've seen no QSL's reported in quite some time, Clark. Even long before the war Baghdad was not very reliable in the QSL department. For all that, it may well be there's no mail service to Iraq.

Tom Robertson in New Albany, Mississippi says Radio Pakistan wants reports from US listeners on their slow speed news bulletin, which is aired at 1105-1120 on 17900 and 21520. Also for the station's English service between 1700 and 1800 on 9418 and 11570. Address reports to Mr. Anwer Inayet Khan, Frequency Management Controller's Office, Radio Pakistan, Broadcasting House, Constitution Avenue, Islamabad.

Miss Velichka Cholakova, from Bulgaria, is a DX'er now studying political science at Northeast Missouri State University and would like to meet any other DX'ers in that area. You can contact her at CH 447, NMSU, Kirksville, MO 63501.

Shortwave listeners (as well as ham operators and scanner enthusiasts) who live in the Cincinnati or Dayton, Ohio areas are invited to join "Monix," an informal group which meets on the second Saturday of each month at the VOA Bethany relay station in West Chester, Ohio. They are active in many areas, including operating a local VHF SWL net and a listening post bulletin board service. For more information contact Mark Meece, N8ICW, 7917 Third St., West Chester, OH 45069-2212.

Virginia Beach is getting closer. Well, actually Virginia Beach hasn't moved a centimeter, but the date for the big Pop\*Comm Worldwide SWL Conference there is getting closer and closer. We're looking forward to seeing you there October 2 and 3! Look elsewhere in the magazine for more information!

Remember to "keep those cards and letters coming." Loggings should be by country, be double spaced (at a minimum) and have your last name and state abbreviation after each item. Sorry, but if you don't follow

these simple guidelines we just can't use your logs. We also need station schedules and literature, station photos, shack photos, spare QSL's you don't need returned and, of course, your letters, comments, questions and so on. Thanks for your continuing participation!

Here are this month's logs. All times are in UTC (0000 = 7pm EST, 6pm CST, etc.) Language broadcast is assumed to be English unless otherwise noted as SS (Spanish), AA (Arabic) etc.

#### SWBC Loggings

**Albania:** Radio Tirana, 9580 at 0130 to 0155 close. (Behrendt, NE) 0230. (Holt, MA)

**Algeria:** Radio Algiers International on 15208 at 2002. (Holt, MA)

**Angola:** Radio Nacional Angola, 7245 at 0522 in PP with songs, commentary, time checks, ID at 0532. (Robertson, MS)

**Antigua:** Deutsche Welle relay, 6160 at 0900. (Behrendt, NE) 9670 at 0502 (Gentry, IL)

BBC Relay, 17840 at 1515. (Tucker, GA)

**Argentina:** RAE, 11710 at 0126 to 0200 with news. ID, guitar music. (Sooy, NJ)

**Ascension Island:** BBC relay, 11750 at 0103. (Pappas, SD) 21660 at 1515. (Moser, PA)

**Austria:** Radio Austria Int'l, 6155 and 13730 at 0436. (Sooy, NJ) 9870 at 0310 in GG, into EE at 0328. (Pappas, SD) 11780//13730 at 1553. (Zamora, CA)

**Australia:** Radio Australia, 5880 at 1850, 6060 at 1906, 6080 at 1924, 9700 at 0730 and 9710 at 0815. (Crook, Guam) 5995 at 1229. (Pappas, SD) 6020//6080//7240//9710 at 0916 in Tok Pisin. Also 11910 at 1643 sign on. (Lamb, NY) 9510 at 1120. (Gasque, SC) 9580 at 1527. (Low, TX) 9870 at 0115, 11855 at 2307, 15240 at 2250 and 15365 at 2205. (Sooy, NJ) 11800 at 1530. (Gentry, IL) 11880 at 1656. (Vaage, CA) 13755 at 1600. (Badie, AZ) 17795 in FF at 0025, into EE at 0030. (Zamora, CA) 21740 at 2300 in FF. (Cohen, ON)

ABC, Perth, 6140 at 1417. (Zamora, CA)

VNG time station, 8638 with CW ID at 0829. (Morgan, UT)

**Belgium:** Radio Vlaanderen (Flanders) Int'l, new 7370, parallel 9930 at 0028 with IS, ID. (Lamb, NY) 15540 at 1902. (Holt, MA) 21810 at 1409. (Moser, PA)

**Benin:** Radio Parakou, 5025 at 2139 in FF with rock, ID, local music, anthem and off at 2200. (Lamb, NY)

**Botswana:** Voice of America relay, 7265 at 0323 with "Daybreak Africa" and African news. (Zamora, CA)

**Brazil:** Radio Cultura do Para. Belem, 5045 at 0150 in PP with pops. (Behrendt, ME)

Radio Bandeirantes, 6090//11925 at 0228 in PP with pops, ID, jingles, commercials. (Lamb, NY)

Radio Nacional Amazonia, 11780 at 0830 with IDs, pops, fado music. (Lamb, NY)

Radio Aparecida, 11855 at 0209 in PP with IDs, Brazilian and Johnny Mathis music. (Lamb, NY)

Radio Universo, 9565 at 1037 in PP with mostly PP pops. (Gasque, SC)

Radio Novas de Paz, 9515 at 0915 in PP with continuous PP pops, then woman announcer. (Gasque, SC)

Radio Nacional, 15445 at 1253 with music, ID in PP. (Moser, PA)

**Bulgaria:** Radio Sofia, 7225 at 2302. (Holt, MA) 9700 at 0100; 0435. (Robertson, MS; Sooy, NJ) 11720 at 1945 (Behrendt, NE)

**Canada:** Radio Canada Int'l, 6150 (via Japan) at 1430 sign on in RR. (Zamora, CA) 11855 at 1343. (Pappas, SD) 13670 at 1805. (Low, TX) 15260 at 1818. (Badie, AZ) 15325//17820 at 2014. (Gentry, IL)

Radio Monte Carlo Sackville relay, 5960 at 0402 in AA. (Lamb, NY)

CHNX, relay CHNS on 6130 at 1005 with oldies. (Pappas, SD)

CKZU, relay CBC network on 6160 at 1357. (Pappas, SD) 1414. (Zamora, CA)

CKZN., 6160 at 1049 with "Weekend Arts Magazine." (Pappas, SD)

#### Abbreviations Used in Listening Post

AA	Arabic
BC	Broadcasting
CC	Chinese
EE	English
FF	French
GG	German
ID	Identification
IS	Interval Signal
JJ	Japanese
mx	Music
NA	North America
nx	News
OM	Male
pgm	Program
PP	Portuguese
RR	Russian
rx	Religion/ious
SA	South America/n
SS	Spanish
UTC	Coordinated Universal Time (ex-GMT)
v	Frequency varies
w/	With
WX	Weather
YL	Female
//	Parallel Frequencies

CFVP, relay CFCN, 6005 at 1240, ID 1246. (Pappas, SD)

CIQX, relay CIQC, "Country Coast to Coast" at 1153. (Pappas, SD)

CFRX, relay CFRB, 6070 at 1245. (Tucker, GA)

**China:** China Radio Int'l, 7405 at 1523. (Badie, AZ) 9655 at 1248, off 1254. (Tucker, GA) Here and //15440 at 1205. (Moser, PA) 9690 (via Spain) at 0326. (Sooy, NJ) 9770 (via Mali) at 0008. (Cohen, ON) 11715 (via Mali) at 2100. (Behrendt, NE) 11755 at 0900. (Crook, Guam) 11895 at 2330. (Holt, MA) 15130 to South Africa (via Mali) at 1638. (Zamora, CA)

**Colombia:** Ondas del Meta, Villavicencio, 4885 at 0949 in SS with Latin music, IDs, time checks, "informe oficial" and news. (Robertson, MS)

Radio Bucaramanga, 4845 at 0205 in SS with pops. (Behrendt, NE) (Only active occasionally. Editor) La Voz del Rio Arauca. Arauca, 4895 at 0200 with SS pops. (Pappas, SD) 1045 with news. (Robertson, MS)

La Voz del Cinaruco, Arauca, 4865 at 1049 in SS. (Robertson, MS)

Caracol, 5075 at 0415 and 6150 at 0522, all SS. (Sooy, NJ)

**Congo:** RTV Congolaise, 4765 at 2120 in FF with drums, news, interview. (Lamb, NY)

**Costa Rica:** TIFC, 5055 at 0115 in SS with classical music, religion. (Behrendt, NE)

Radio Exterior de Espana relay, 17870 at 2146 in SS. (Lamb, NY)

Radio For Peace Int'l, 7375 at 0200 with ID, address. (Robertson, MS) 15030 at 2218. (Holt, MA)

**Cuba:** Radio Havana Cuba, 5965 at 0359 in SS. (Vaage, CA) 6010 at 0437 and 9815USB at 0000. (Tucker, GA) 9550 at 0509 and 9815USB at 0134. (Lamb, NY) 9510 at 0631. (Sooy, NJ) 9550 at 1059 sign on to Latin America in SS. (Gasque, SC) 9655 at 0245. (Behrendt, SD) 15165 at 2100 to Europe. (Cohen, ON)

Radio Rebelde, 3365 at 2230 in SS. (Robertson, MS)

**Cyprus:** BBC relay, 21470 at 1303. (Moser, PA)

**Czech Republic:** Radio Prague, 5960//6055/-/7345//9605 at 2108. (Lamb, NY) 5930 at 0000 and 0300. (Holt, MA) 7345 at 0315, ID as Czech Republic. (Sooy, NJ) 9605 at 1809. (Moser, PA)

**Denmark:** Radio Denmark, via Norway, 9560 at 0330 with EE ID, into Danish to 0358 close. (Vaage, CA) 11795 at 2303 in Danish with EE ID. (Sooy, NJ)

**Ecuador:** HCJB, 6205 at 0533 in SS. (Sooy, NJ) 9745 at 0805. (Crook, Guam) 9745//15155 at 0030. (Robertson, MS) 11925 at 0557. (Vaage, CA) 17790 at 1655. (Badie, AZ) 21455USB at 1930. (Gentry, IL)

Radio Popular, 4800 at 1100 in SS with organ music, ID, religious program. (Robertson, MS)

**Egypt:** Radio Cairo, 9745 at 0200. (Moser, PA) 0099 at 2215. Closed 0245. (Behrendt, NE)

**England:** BBC, 3955 at 0401; 6195 at 0730;



Another of the many attractive QSL cards from Radio Japan.



Thom McAdams, KCA6YU, of Lancaster, California does his SWL'ing from this post. His mediumwave, scanner and CB equipment is operated separately.

9640 (via Antigua) at 0730; 9915 at 0231; 11940 (via Lesotho) at 0444; 15390 (Ascension) at 2230 and 15400 (Ascension) at 2305. (Sooy, NJ) 7325 at 2244. (Holt, PA) 9600 (Ascension) at 0329. (Vaage, CA) 11750 (Ascension) at 2300 (Zamora, CA) and 15260 (via Canada) at 1615. (Gentry, IL)

Radio Japan via England, 7230 at 0556. (Lamb, NY)

**Ethiopia:** Voice of the Broad Masses of Eritrea. 7380 at 0323 with IS, drums, sign on and ID by woman in presumed Amharic at 0324. (Robertson, MS)

**Finland:** Radio Finland Int'l, 9560 at 0247. (Sooy, NJ) 0755. (Crook, Guam) 15400 at 1430. (Badie, AZ) Here and 21550 at 1411. (Moser, PA)

**France:** Radio France Int'l, in FF at 0239. (Sooy, NJ) 11670 at 1236. (Moser, PA) 11705 at 1945 to Africa. (Behrendt, NE) 12015 (via Gabon) at 1652. (Vaage, CA) 15530//17620//17795 at 1645. (Holt, MA)

**Gabon:** Africa Number One, 9580 at 0700 in FF. (Robertson, MS) Here at 0500 and 17630 at 1520. (Morgan, UT)

Radio Japan via Gabon, 11925 at 2122. (Moser, PA) 15355 at 1511. (Zamora, CA)

**Germany:** Deutsche Welle, 5960 at 0515; 6045 at 0505; 6100 at 0400; 6115 at 0501; 6120 at 0300; 9545 (Antigua) at 0305; 9690 (Antigua) at 0658 and 9695 at 0301. (Sooy, NJ) 6040 (Antigua); 6145 and 11865 at 0100; 21600 at 1530. Holt, MA) 6085 (via Canada) at 0430 and 13780 at 1700, in GG. (Vaage, CA) 9750 at 0700 in GG. (Crook, Guam) 13790 at 1917. (Moser, PA)

**Ghana:** GBC Radio One, 4915 at 2245 with press review to 2206 sign off. (Robertson, MS) 0545-0630 in EE with classical music before and after 0600 news. (Behrendt, NE) 6130 at 0705 with African music, ID "This is Accra." (Lamb, NY)

**Greece:** Voice of Greece, 9395//9420//1645 at 0335 with Greek music. EE news 0335, back to Greek 0350, off 0352. (Sooy, NJ) 9395//9420 at 0230. (Behrendt, NE) 17525 at 1536. (Moser, PA)

**Guam:** KTWR, 11805 at 0957 sign off. (Morgan, UT) 15200 at 0845 with religious program. (Crook, Guam)

Adventist World Radio-KSDA, 11980 at 1610 with religion. (Moser, PA) 15610 at 2307. (Low, TX)

**Guatemala:** Radio Cultural, 3300 at 0000 in SS with religion. (Robertson, MS)

Radio Chortis, Jocotan, 3380 at 1059 sign on in SS with ID and prayers. (Robertson, MS) 0320 in SS with IDs. "Musica de Hoy" program. (Lamb, NY)

Radio Buenas Nuevas, 4800 at 2358 in local language with religion and music program. (Robertson, MS)

Radio Tezulutlan, Coban, 4835 at 1050 in SS with religion, ID 1057. (Robertson, MS)

**Honduras:** La Voz de Mosquitia, Puerto Lempira, 4910 at 0120 in SS with religion and sermon in local language. (Robertson, MS)

Radio Luz y Vida, 3250 at 0200 in SS with religion. (Robertson, MS)

La Voz Evangelica, 4820, SS with music at 0000. (Robertson, MS)

**Hungary:** Radio Budapest, 9835 at 0220; 0300. (Sooy, NJ; Moser, PA)

**Iceland:** INBS, 11402 at 1848 in Icelandic with reggae and classical music. IDs, bells, news and off 1930. (Lamb, NY)

**India:** All India Radio, 7412 at 1327 with Indian music. (Morgan, UT) 9910 at 1350. (Northrup, MO) Here and parallel 10330 at 1532 with news. ID, 1545 into different language. (Zamora, CA) 11620 at 1800. (Holt, MA) 1950 in Hindi. (Behrendt, NE) 2030. (Gentry, IL)

**Indonesia:** Radio Republik Indonesia, Ujung Pandang on 4753 at 1315 in Indonesian with ID, songs, talk by woman. (Robertson, MS)

**Iran:** VOIRI, 9022 and 11790 at 0030. (Holt, MA) 15084 in Farsi at 0430. (Sooy, NJ)

**Iraq:** Iraqi Republic Broadcasting, 6560 at 0256 in presumed Kurdish with Koran, ID, news. (Lamb, NY) Radio Iraq International, 15250 at 1506 with commentary, some AA music. (Badie, AZ)

**Israel:** Kol Israel, 7465 at 2239 with news. (Gentry, IL) 11587 at 1805 with news. (Badie, AZ) Rashuth Hashidur service in Hebrew on 15165 at 1635. (Low, TX)

**Italy:** RTV Italiana, 9710 at 2200 with news, music. (Crook, Guam)

**Japan:** Radio Japan, 5960 (via Canada) at 0316; 9645 (via Gabon) at 0359 with ID, into JJ. (Sooy, NJ) 9535 at 1555, into JJ at 1600. (Low, TX) 11875 at 1900 and 15170 at 0750. (Crook, Guam) 17825 at 0315. (Vaage, CA)

Radio France Int'l relay, 17710 at 2336 in FF to 0358 sign off. (Lamb, NY)

**Kazakhstan:** Radio Moscow, 9610 at 2300 in SS. (Low, TX)

**Kuwait:** Radio Kuwait, 13620 at 1900. (Holt, MA)

**Lebanon:** Wings of Hope, 11530 at 1755 with AA music. (Bade, AZ)

**Lithuania:** Radio Vilnius, 7150 at 0015 to 0029 close; 0024. (Tucker, GA; Moser, PA)

**Luxembourg:** Radio Luxembourg, 15350 at 1757, all GG on this frequency now. (Lamb, NY)

**Madagascar:** Radio Netherlands relay, 15150 at 1550. (Moser, PA)

**Malagasy:** RTV Malagasy, tentative on 3232 at 0347 with music, man in presumed Malagasy. (Robertson, MS)

**Malaysia:** Radio Malaysia, Sarawak, 5030 at 1348 with US pops, Malay. (Zamora, CA)

**Mali:** Radiodiffusion Television du Mali, 5995 at 0700 with news in FF and vernaculars, native music. (Behrendt, NE)

China Radio International relay, 9770//11715 at 0011. (Moser, PA) 11715 at 0348. (Sooy, NJ)

**Malta:** Deutsche Welle relay, 9545 at 1102 in GG. (Gasque, SC) 11865 at 0104. (Moser, PA)

**Mexico:** Radio Mil, 6010 at 1330 in SS with commercials, presumed news. (Northrup, MO)

Radio Educacion, 6185 at 2230 in SS, running to

0700. Also 1200 to 1330 fade out. Lots of good music. (Robertson, MS)

**Morocco:** RTV Marocaine, 15345 at 1800 in AA with ID, north African music. (Robertson, MS)

Radio Medi Un, 9575.9 at 1015 in FF with lots of talk, occasional music. ID and frequency at 1023. (Gasque, SC)

VOA Tangier relay, 9530 at 0610 and 9740 at 0530 sign on. (Lamb, NY)

**Namibia:** Namibian Broadcasting Corp., 3290 at 0430 with news, weather. ID in EE. (Lamb, NY)

**Netherlands:** Radio Netherlands, 6020 at 0021. (Sooy, NJ) 9605 (via Madagascar) at 1918. (Crook, Guam)

**Netherlands Antilles:** Radio Netherlands Bonaire relay, 6165 at 0015. (Cohen, ON) 9590 at 0335. (Sooy, NJ) 11720 at 0337. (Vaage, CA) 11835 at 0045. (Holt, MA) 17605//21590 at 1934. (Zamora, CA) 21515 at 1753; 1830. (Gentry, IL; Badie, AZ)

**New Zealand:** Radio New Zealand Int'l, 9700 at 0710; 0910. (Gentry, IL; Moser, PA) 15120 at 0359 with bellbird IS, ID at 0400. "Sports Roundup" (Tucker, GA) 17770 at 2334. (Zamora, CA) 0100 with cricket match. (Cohen, ON)

**Nigeria:** Voice of Nigeria, 7255, 2128 in FF. (Lamb, NY) 0518 with "Morning Flight" (Gentry, IL) 0630 with news, press review. Into FF at 0700. (Robertson, MS)

Radio Nigeria, Kaduna, 4770 at 0445 with music. "News Nationwide" at 0500. (Behrendt, NE)

**North Korea:** Radio Pyongyang, 6560//7580 at 0938 in JJ and 11335//13760 at 0030 in EE to 0047 sign off. (Lamb, NY) 11335 at 0002. (Sooy, NJ) 11335 at 0003 and 11700 at 2302. (Holt, MA) 13760 at 0017. (Moser, PA) 15180 at 0830 and 15340 at 0705. (Crook, Guam)

**Northern Marianas:** KFBS, 11650 in RR with ID. Fade out by 0940. (Morgan, UT)

KHBI, 9530 at 1410 with religious interview. (Moser, PA)

**Norway:** Radio Norway Int'l, 9560 at 0100 to 0129 close and into Denmark relay. (Behrendt, NE) 9650 at 0400 with sign on, EE ID, into Norwegian. (Vaage, CA) 11795 at 2300 sign on. (Zamora, CA) 25730 at 1259 with sign on. (Moser, PA)

**Oman:** BBC Masirah Island relay, 15310 at 1301. (Moser, PA)

**Palau:** KHBN, 9830 at 1157 with ID "This is KHBN, The Voice of Hope for All Asia." (Lamb, NY)

**Paraguay:** Radio Nacional, 9735 in SS at 2355; 0100. (Sooy, NJ; Behrendt, NE)

**Peru:** Radio Tacna, tentative, 9504.9 with fast-paced SS morning show, lots of sound effects, bits of pop. Buried by VOA at 1130. (Gasque, SC)

**Philippines:** VOA relay, 11805//15205 in Indonesian at 2303 to sign off at 2359. Also 9770/-/11760//15185//15290//17735 at 2310. (Lamb, NY) 17820 at 2302. (Low, TX)

FEBC, 9420 at 1523 in presumed CC to IS at 1559 and off, 9820 at 1209 in listed Cantonese. 15450 at 2358 in EE. (Lamb, NY) 11995 at 1500. (Pappas, ND)





PRESIDENCIA DE LA REPUBLICA  
Z. P. 1 y Z. P. A. 1  
Radio Nacional del Paraguay  
Montevideo y Estrella

Asunción, 16 de octubre de 1991

Señor  
RONALD A. GOVE  
7535 Flamewood Drive  
Clarksville, Maryland 21029  
ESTADOS UNIDOS

Estimado amigo oyente:

Con verdadero gusto recibimos su carta y apreciamos su interés por los programas de nuestra Emisora así como su deseo de conocer las frecuencias en que emitimos.

RADIO NACIONAL DEL PARAGUAY transmite en las siguientes frecuencias: ONDA MEDIA: 920 Khz., 50 kilovatios; ONDAS CORTAS: 31 metros 9.735 Khz, 49 metros 6.025 Khz.

Al manifestarle nuestra entera disposición para un fluido intercambio radial, me complace saludarlo atentamente.-



OBS: Muchas gracias por las hermosas postales que nos ha enviado de la Ciudad de Washington!!!

(Robertson, MS) 0100. (Hall, MA) 0505. (Sooy, NJ)  
**Sudan:** Radio Omdurman, 7200 at 0250 with IS, anthem, AA sign on. (Robertson, MS) tentative on 9190 at 0303 in AA. Prayer, into AA music. (Sooy, NJ)

**Swaziland:** Trans World Radio, 15345 at 1140. (Moser, PA)

**Sweden:** Radio Sweden, 11705 at 0210 with ID, sports. (Sooy, NJ) 17870 at 1605. (Gentry, IL)

**Switzerland:** Swiss Radio Int'l, 6135 at 0200. (Badie, AZ) 0427. (Vaage, CA) 9535 at 1113 with talk, Swiss music. (Gasque, SC) 9885 at 0201 and 12035 at 2205. (Sooy, NJ) 13635 to Africa at 1507. (Zamora, CA) 12035 at 0018. (Gentry, IL)

**Syria:** Radio Damascus, 12085 at 2126 with mid-east news. (Moser, PA)

**Taiwan:** Voice of Free China via WYFR, 5950 at 0330. (Vaage, CA) 7130 at 1410 in Japanese. (Zamora) 9680. via WYFR, at 2020. (Badie, AZ) 11915 at 2213. (Holt, MA)

WYFR via Voice of Free China facilities, 9280 at 0730 fade in CC. (Robertson, MS)

**Thailand:** Radio Thailand, 11905 at 1115 in Vietnamese. IS, melody and anthem at 1130 and into EE. (Robertson, MS)

**Togo:** Radio Lome, 5045 at 0529 sign on with anthem, ID, religious service, news. (Lamb, NY)

Radio Kara, 3222 at 2230 in FF with ID, EE songs and off at 2305. (Robertson, MS)

**Tunisia:** RTV Tunisienne, 7475 at 0427 in AA with prayers. Off 0432. (Sooy, NJ)

**Turkey:** Radio Ankara, 9445 at 2350 (Badie, AZ) 0230 in TT (Behrendt, NE) 0430 sign on. (Moser, PA)

**Ukraine:** Radio Ukraine Int'l, 7180//7195/-/7240 at 0100. (Holt, MA)

**United Arab Emirates:** UAE Radio, Dubai, 11795 at 1607. (Moser, PA) 21505 at 1330 with news. (Cohen, ON)

UAE Radio, Abu Dhabi, 9605 at 2335. (Sooy, NJ) 9605//11710 at 2300. Into AA at 0000. (Sooy, NJ) 11815 at 2304. (Holt, MA)

**Uzbekistan:** Radio Tashkent, 9540//15470/-/17745 at 1200 with sign on, ID, news. (Moser, PA)

**Vanuatu:** Radio Vanuatu, 3945 at 1020 with easy listening EE music, announcer in Bislama. (Robertson, MS)

**Vatican City:** Vatican Radio, 5882 at 2049; 6245//7250 at 0559; 9645 at 0905. (Lamb, NY) 7305 at 0348. (Badie, AZ) 9605 at 0250. (Sooy, NJ) 15090 at 1557; 0645. (Moser, PA; Crook, Guam)

**Venezuela:** Ecos del Torbes, 4980 at 0900 in SS with pops, commercials, frequent IDs. (Behrendt, NE) 0417. (Low, TX)

Radio Rumbos, 4970 at 0415 in SS. (Low, TX) 0200 with pops. (Behrendt, NE)

Radio Nacional, 9540 at 1107 with interview, ID, mentions of Venezuela. (Gasque, SC)

**Unidentified:** 5000 with futbol play-by-play of Venezuelan teams, no ID. Heard as early as 0100 and as late as 0330. (Gasque, SC)

**Yugoslavia:** Radio Yugoslavia, 9580 at 0101. (Holt, MA) 17740 at 1254. (Moser, PA)

Radio Veritas, tentative, 9520 in CC or dialect at 1116. (Gasque, SC)

**Poland:** Polish Radio Warsaw, 9525 at 1810; 1950. (Moser, PA; Holt, MA)

**Portugal:** Radio Portugal, 9570 at 0230 with ID, news. (Tucker, GA) 9705 at 0230. (Badie, AZ) 11840 at 2150 with multi-lingual sign on and opening at 2200. (Behrendt, NE)

Radio Free Europe on 7255 at 0548 in Polish. (Lamb, NY)

**Romania:** Radio Romania Int'l, 5990 at 0400 and 6155 at 0230. (Holt, MA) 9690 at 1931. (Moser, PA) 11810 at 0645 to 0715 closing EE to the Pacific. (Behrendt, NE)

**Russia:** Radio Moscow (various sites) 5950 at 1900, 17570 at 0725. (Crook, Guam) 7110 at 0329. (Sooy, NJ) 7150//7180 at 2240. (Holt, MA) 7180 at 2243. (Cohen, ON) 15540//17730//21755/-/21785 at 1457. Kremlin chimes, ID, news. (Tucker, GA)

Radio Moscow home service via Yakutsk, 7200 at 0955 in RR. (Robertson, MS)

Radio Galaxy, 9880 in EE at 2030 with pops, many ID's and frequency announcements, IS at 2056 to 2100 off. (Behrendt, NE)

Radio Ala, 7400//11685//11965 in RR with folk music, news, IS. (Lamb, NY)

Magadan Radio, 9530 in RR with RR pops 0930,

IS and time signal 1000, assumed news. (Gasque, SC)

Radio Yunost, 7473 1 in RR. Usual canned ID and EE message asking for advertising, RR pops. Not heard next night or since. (Gasque, SC)

**Rwanda:** Deutsche Welle relay, 7225 at 0435. ID at 0500. (Sooy, NJ)

**Saudi Arabia:** BSKSA, 9780 at 2000 in AA with ID, news. (Robertson, MS) 9870 at 1846 in AA. (Pappas, SD)

**Seychelles:** FEBA, 11810 at 0345 in Swahili; 15145 at 0329 with IS, ID, Amharic religious program. (Lamb, NY)

**Singapore:** Radio Singapore, 6155 at 1400 with time check, news in Malay. (Zamora, CA)

**Solomon Islands:** SIBC, 9545 at 1000 to 1130 with National Service. Closing and anthem at 1126. (Behrendt, NE)

**South Africa:** Channel Africa, 15430 at 1748; 0622. (Lamb, NY; Moser, PA)

Radio Orion, 4810 in EE/Afrikaans at 0200 with soft pops. (Behrendt, NE)

BBC Meyerton relay, 11940 at 0425 with IS, sign on in PP. (Moser, PA)

**South Korea:** Radio Korea, 7550 at 0800 with news. (Crook, Guam) 9570 at 1400 sign on, frequency schedule, news. (Zamora, CA) 15575 with 0025 sign on with IS, ID, news. (Lamb, NY)

**Spain:** Spanish Foreign Radio, 9530 at 0000.

That's the end of the line. Please raise your glass to the following who did the work this month: Kenneth G. Sooy, Sr., Oceanville, NJ; William Moser, New Cumberland, PA; Larry R. Zamora, Highland, CA; Mark A. Northrup, Gladstone, MO; David A. Gasque, Orangeburg, SC; Marie Lamb, Brewerton, NY; Christopher D. Holt, Assonet, MA; Bjorn F. Vaage, Granada Hills, CA; Murray Cohen, Fonthill, Ontario; Sheldon F. Crook, Deddon, Guam; Steve Morgan, Salt Lake City, UT; Tom Robertson, New Albany, MS; Marina Pappas, Huron, SD; Clark R. Badie, Glendale, AZ; Brad Low, Jacksonville, TX; Stephen C. Behrendt, Lincoln, NE and Robert Tucker, Savannah, GA.

Thanks to all. Until next month, good listening!

■

*This form letter QSL from Radio Nacional in Paraguay was received by Ronald Gove in Maryland. Radio Nacional can often be heard in the evenings on 9735, playing some excellent local music.*

Radio Veritas, tentative, 9520 in CC or dialect at 1116. (Gasque, SC)

**Poland:** Polish Radio Warsaw, 9525 at 1810; 1950. (Moser, PA; Holt, MA)

**Portugal:** Radio Portugal, 9570 at 0230 with ID, news. (Tucker, GA) 9705 at 0230. (Badie, AZ) 11840 at 2150 with multi-lingual sign on and opening at 2200. (Behrendt, NE)

Radio Free Europe on 7255 at 0548 in Polish. (Lamb, NY)

**Romania:** Radio Romania Int'l, 5990 at 0400 and 6155 at 0230. (Holt, MA) 9690 at 1931. (Moser, PA) 11810 at 0645 to 0715 closing EE to the Pacific. (Behrendt, NE)

**Russia:** Radio Moscow (various sites) 5950 at 1900, 17570 at 0725. (Crook, Guam) 7110 at 0329. (Sooy, NJ) 7150//7180 at 2240. (Holt, MA) 7180 at 2243. (Cohen, ON) 15540//17730//21755/-/21785 at 1457. Kremlin chimes, ID, news. (Tucker, GA)

Radio Moscow home service via Yakutsk, 7200 at 0955 in RR. (Robertson, MS)

Radio Galaxy, 9880 in EE at 2030 with pops, many ID's and frequency announcements, IS at 2056 to 2100 off. (Behrendt, NE)

Radio Ala, 7400//11685//11965 in RR with folk music, news, IS. (Lamb, NY)

Magadan Radio, 9530 in RR with RR pops 0930,

## Beaming In (from page 6)

port some non-commercial stations. Four times a year, and for weeks at a time, at least one FM and two TV stations run pledge drives to do this. In-progress programming is shut down for up to twenty minutes at a clip and replaced with fumbling and awkward front office geeks moaning and crying for funds to pay for the particularly worthwhile and unique programs being offered. Curiously, their pitch is how they need the funds in order to continue presenting this wonderful programming without commercial interruptions!

Who cares? The non-commercial interruptions are worse! I do support PBS, and have regularly contributed to it for years. But I'd prefer to put up with a few minutes an hour of skidding cars and ecstasy-face yogurt commercials than be subjected to this calculated and unrelenting sackcloth and ashes routine three or four months a year. I would sooner spend an hour at the mercy of my nephew, "Dr. Lenny," the sadistic Dentist from Hell, than sit through twenty minutes of this amateurish fundraiser bleating injected arbitrarily several times into a particularly worthwhile documentary, concert, film, or drama.

If the combination of corporate grants, private endowments, public funds, plus

audience contributions from program subscriptions still doesn't combine to adequately support these stations, then they should severely cut back their operations, get smarter management, or else go commercial. I don't know why the FCC allows non-commercial stations to get away with this hard-sell on-the-air fund-raising anyway. Commercial products (CD's, tapes, books, T-shirts, etc.) are hawked and then offered in exchange for pledges of specific amounts. Sounds very commercial to me.

While I'm jotting down these notes, I'm listening to an AM station two states away. They are playing excellent music, but why is the deejay so determined to start playing the music while he is still talking? And he is tail-ending—not waiting until the music is finished until he begins yakking again. Don't these deejays realize how annoying that is?

I used to think that keeping up with technology would be the challenge of the 1990's. It turns out to be more of a challenge just trying to understand our own national broadcast media.

Jeeves, put away this infernal receiver and see if you can find where I left my Discman.

## YOU AIN'T HEARD NOTHIN' . . . YET

Since 1967, CRB Research has been the world's leading publisher and supplier of unique hobby and professional books and information including:

- Scanner Frequency Guides
- Shortwave Frequency Guides
- Military/Federal Communications
- Broadcast Station Registries
- Undercover Communications
- Survival Communications
- Covert Operations
- Electronic Espionage
- Surveillance
- Monitoring
- Cryptography & Codes
- Bugging
- Wiretapping
- Communications Antennas
- Computer Technology!
- & Other Related Topics!

**Ask for Big  
Free Catalog**

Business Hours: 9 am to 3 pm Eastern (Mon., Tues., Thurs., Fri.)  
Closed Wed., and Holidays.

**CRB RESEARCH**

P.O. Box 56

Comack, NY 11725

Phone: (516) 543-9169/FAX: (516) 543-7486

CIRCLE 55 ON READER SERVICE CARD

## Why buy a TNC? PC HF FAX + PC SWL \$179.00

### SPECIAL COMBINATION OFFER

For a limited time, if you order PC HF FAX \$99 (see our other ad in this issue), you can add our new and improved PC SWL 3.0 for \$80.00 instead of our regular low price of \$99.00.

PC SWL contains the hardware, software, instructions and frequency lists needed to allow you to receive a vast variety of digital broadcasts transmitted over shortwave radio. All you need is any IBM PC or compatible computer and an SSB shortwave receiver. The product consists of:

Demodulator  
Digital Signal Processing Software  
200 Page Tutorial Reference Manual  
World wide Utility Frequency List  
Tutorial Audio Cassette with Samples

PC SWL automatically decodes Morse code, Radio Teletype, FEC (forward error correcting code), SELCAL (selective calling transmissions), and NAVTEX.

PC SWL lets you tune in on world press services with up to the minute news, meteorological broadcasts, ham radio operators, coastal shore stations, aviation telex and much more digital action on the shortwave bands. Find all the utility station action you have been missing. PC SWL software uses the processor in your PC to do the work, why pay for another expensive box when a simple interface and your PC can do the job?

#### ADVANCED FEATURES:

- Tuning Oscilloscope
- Digital Waveform Presentations
- Auto Calibration and Code Recognition
- Continuously Tunable Filter Frequencies
- Variable Shift
- Adjustable CW Filter Sensitivity
- Unattended Capture and Printing
- Integrated Text Editor
- Integrated Log and Database
- Shell to DOS applications
- RTTY/NAVTEX Background Operation
- Seamless Integration with PC HF Facsimile

Call or write for our complete catalog of products. Visa & MasterCard welcome.

**Software Systems Consulting**  
615 S. El Camino Real, San Clemente, CA 92672  
Tel: (714) 498-5784 Fax: (714) 498-0568

CIRCLE 76 ON READER SERVICE CARD

## ART-1

**ART-1:** A complete interface system for send and receive on CW, RTTY (Baudot & ASCII) and AMTOR, for use with the Commodore 64/128 computer. Operating program on disk included.

**\$199.00**

**AIR-1:** A complete interface system for send and receive on CW, RTTY (Baudot & ASCII) and AMTOR, for use with Commodore VIC-20. Operating program in ROM.

## AIR-1

**\$99.95**

## SWL

**SWL:** A receive only cartridge for CW, RTTY (Baudot & ASCII) for use with Commodore 64/128. Operating program in ROM.

**\$69.95**

**AIRDISK:** An AIR-1 type operating program for use with your interface hardware. Both VIC-20 and C64/128 programs on one disk.

**\$39.95**

## AIRDISK

**AIR-ROM:** Cartridge version of AIRDISK for C64/128 only.

**\$59.95**

## MORSE COACH

**MORSE COACH:** A complete teaching and testing program for learning the Morse code in a cartridge.

For C64 or C128.

**\$49.95**

VEC SPECIAL

**\$39.95**

G AND G ELECTRONICS  
OF MARYLAND

8524 DAKOTA DRIVE, GAITHERSBURG, MD 20877

(301) 258-7373



CIRCLE 63 ON READER SERVICE CARD



# MAILBAG

## LETTERS TO THE EDITOR

Each month we select representative reader letters for our Mailbag column. We reserve the right to condense lengthy letters for space reasons. All letters submitted must be signed and show a return address. Upon request, we will withhold sender's name should the letter be used in Mailbag. Address letters to Tom Kneitel, Editor, Popular Communications Magazine, 76 N. Broadway, Hicksville NY 11801.

### He's Got Us Covered

I could not believe what you chose to put on your April issue cover. One would have thought the printer confused your publication with *Rolling Stone* Magazine. Surely, any of the Radio Luxembourg photos would have been better than the one you chose of the rock musician.

David B. Eason,  
Chevy Chase

About 10 percent of my mail comes from people who begin their comments by stating that they cannot believe the existence of things they read and see. Hardly a good recommendation for tak-

ing their observations seriously. We thought the lively cover tied in appropriately with Chuck Robertson's lead story on scanning show biz. But maybe I'm just making that up. Perhaps the printer did make a mistake. Mr. Eason should have checked to see if *Rolling Stone's* April front cover had a photo of Radio Luxembourg before he wrote this letter.—Editor.

### Comments Regarding Privacy

I have followed the comments on privacy with some interest. I agree that the ECPA is a monumental pain. The airwaves should be open to all, and those who demand security should be required to scramble. Things monitored on a scanner are a big difference from theft. Theft occurs when a hacker breaks into a computer system. It can't be excused because the system operator failed to have sufficient safeguards. That would be like saying it's OK for me to use your lawn mower because you didn't have it chained when you went in the house to get a cold drink. What became of basic honesty? Passwords to computer systems always show up on bulletin boards, so they can't be relied upon.

As for human safeguards, all you have to do is flood the security ops to the system's capacity. Then the system is overloaded and it goes down. Vandalism accomplished.

Holton F. Brown,  
Baltimore, MD

### Observations

In May of last year I received my first Braille issue of *Popular Communications*. Although I had been interested in short-wave listening for many years, I had gotten discouraged at times because information on stations was not available to me. Your magazine has reawakened my interest and enthusiasm and I wanted to let you know how much it is appreciated. I am so pleased that it may be accessed in Braille.

I wonder if any blind people have been successful using cellular phones. In January of 1991 I bought one thinking it would be useful to me as I travel because finding a pay phone in a bus terminal is a problem for me. I thought it would work everywhere, but the unit I bought didn't seem to work anywhere. Maybe there was something I didn't know.

Arline Davidson,  
Mesa, Ariz.

## DELTA COMM™ DSS

### Digital Signal Strength Option For Your ICOM™ R7000

DELTA COMM™ I-7000 and your MS-DOS computer integrated with the Delta Research custom CI-V interface and optimized software will not just control but will maximize the potential of your ICOM™ IC-R7000's monitoring capability.

- CYBERSCAN function allows scan file tracking control of systems employing frequency hopping techniques.
- Spectrum log at speeds in excess of 1300 channels a minute, generate a real time histogram of activity and create scan database file automatically.
- Birdie log during frequency search automatically characterizes your R7000, then locks out those frequencies.
- Activity log function continuously monitors and logs all frequencies of a scan database while displaying active, was active and never active channels.



Optional DELTA COMM™ DSS (Digital Signal Strength) upgrade for your DELTA COMM™ I-7000 communication manager.

- Innovative interface design allows digitizing and storing the R7000 signal level information with 8-bit accuracy via your computer's game/joy stick port.
- DSS allows user programmable upper and/or lower signal level detection limits during DELTA COMM™ I-7000's spectrum log, scan and search functions.
- Log signal strength information to printer or delimited log file while DELTA COMM™ I-7000 is scanning or activity logging the selected database file.

DELTA COMM™ I-7000 communication manager program includes all cabling, manual, UL listed power supply and Delta Research custom CI-V interface for \$299.00 + \$8.00 (U.S.) or \$25.00 (foreign) S&H. The DELTA COMM™ DSS interface upgrade comes complete with easy to follow NO SOLDER installation instructions, all cabling and 8-bit DSS A/D converter module (game port required) for \$99.00 + \$8.00 (U.S.) or \$25.00 (foreign) S&H and is available as an upgrade option to registered I-7000 users. Contact us for additional information on DELTA COMM™ communication managers for ICOM™ R7100, R71A, R72 and IC735.

**Master Card** **Delta Research** **AMERICAN EXPRESS**  
Box 13677 • Wauwatosa, WI 53213 • FAX/Phone (414) 353-4567

## High Performance 800MHz

FREE CELLULAR FREQUENCY CHARTS!

### MAX 800 GROUND PLANE

- Absolutely the best reception... 10 times better!!!
- Astounding results outside using our RG6 cable
- Mount directly on base or hand-held scanner

Only \$19.95

Base scanner adaptor - \$15.00  
Hand-held scanner adapter - \$12.00  
50 ft RF-6 cable assembly - \$35.00

Max Cellular Mag Mount - mobile 800 scanner antenna - \$29.95  
The Stinger - compact 800 MHz hand scanner antenna - \$7.95  
Loop Yagi - highly directional 15dB gain (3ft boom) - \$75.00

### Cordless and Baby Monitors

FREE CORDLESS FREQUENCY CHARTS!

### MAX 46-49 MHz DIPOLE

- The very best cordless phone and baby monitor antenna
- Hear conversations for miles around - don't miss anything!
- Install inside or outside
- Includes 50ft RG8X - BNC

Only \$49.95

## MAX System™

Antenna and Accessories

1-800-487-7539 ORDERS ONLY  
508-768-7486 FAX  
508-281-8892 INFO  
SASE for free catalog

146/220/440/GMRS GP	25.95
Telescopic Whip	12.95
Telescopic GP	29.95
146/220 Mag Mount	29.95
146/440 Mag Mount	29.95
BNC Mag Mount	12.95
Custom Ground Plane	39.95
Telescopic Mag Mount	29.95
3 Element 2m Quad	39.95

Send Payment To: Cellular Security Group  
4 Gerring Road  
Gloucester, MA 01930

CK-MO-MC-VISA Accepted (MA add 5%)  
US shipping and handling \$4.00

CIRCLE 60 ON READER SERVICE CARD

## High Frequency Feedpoints

**H**igh frequency 2-30 MHz SSB communications are essential for all mobile communication command posts. Amateur radio operators may pass emergency and health and welfare messages on ham bands 10 meters through 160 meters. High frequency SSB FEMA channels using ALE (automatic link establish) protocol may take equipment, such as the SGC 2000 HF SSB, and allow it to automatically scan and seek the best FEMA SSB channel for the desired communications path.

U.S. Coast Guard Auxiliary and Civil Air Patrol units also have their own high frequency SSB nets. These nets do not necessarily require that the emergency command post operator hold a valid amateur radio license. In other words, the non-ham may still have many channels to intercommunicate on HF SSB at the emergency command post.

Recent breakthroughs in equipment technology for high frequency 100-watt SSB use makes for an easy command post installation. On the SGC Model 2000, the head unplugs from the body of the gear, and can go just about anywhere including on the dash with a suction cup window mount. Multiple heads may be installed for up to 7 different command post stations. Intercom is part of the package.

The new Kenwood TS-50S ham rig is so incredibly small that it mounts in an area where the CB radio may originally have been installed. Although the Kenwood TS-50 does not have a detachable head, remote control capabilities are indeed possible with the proper interface to its communications port on the back of the unit. The Amateur Radio Engineering Ham Link (TM) might interface with the TS-50, and allow you to control everything via a cordless telephone set, up to 50 feet away from the command post.

Command post high frequency antenna systems are tied into the equipment down below via coaxial cable. Top quality coax should be used to minimize RF leakage that could interfere with other systems onboard. RG213 is a good choice, and offers less than 1 dB attenuation for most command post runs between 2 MHz - 30 MHz. It takes the standard PL-259, and is relatively flexible and has a waterproof jacket.

The HF whip antenna is usually pre-tuned to the desired band of operation. The taller the whip, the better its operation. Ham whips are plentiful, and the Out-

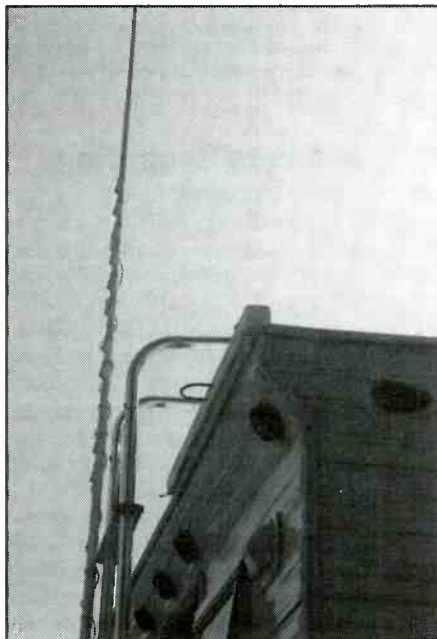

*The performance of this high frequency whip improved when it was angled back away from the command post's metal ladder.*

backer (TM) antenna is also available on both ham frequencies as well as on ITU bands 2 MHz, 4 MHz, 6 MHz, 8 MHz, 12 MHz, 16 MHz, and 20 MHz. This gives you all of the Civil Defense, FEMA, U.S. Coast Guard, and MARS frequencies. You could also utilize the SGC QMS system which is an outside-mounted, waterproof antenna coupler that tunes the SGC 303 8-foot whip antenna to any frequency between 2 MHz - 30 MHz.

Whatever high frequency antenna system you go with, mounting the base of the whip at the top of your command post roof is essential for maximum performance. If the whip is placed just a few feet down from the top of your command post, the metal siding on your vehicle will dramatically reduce the effectiveness of the whip, and detune it to the point where SWR escalates to above 5:1. This causes your transceiver to automatically power down to protect the finals, and your resultant signal will drop well into the noise floor. Just 2 feet down from the top of the roof is enough to render most antenna systems inoperative.

If the command post is stationary, a good place to mount the whip would be at the top of the aluminum ladder that leads to the roof level. The tip-top point on the ladder should accommodate a stainless steel marine mount, available from Valor

Antenna Company. This puts the ground plane directly below the HF whip, and you will have a terrific signal and a perfect 50-ohm match.

But if the command post must be mobile, there may be a way to get your high frequency whip to perform reasonably well yet still stay below the typical 16-foot height limit for vehicles in the United States. You can mount the whip several feet down from the top, and angle it back until you hear the noise come up in the receiver, and the SWR drop to an acceptable level. A quick way to check your match is to use the portable MFJ SWR analyzer that lets you sweep the band for a minimum SWR check without actually putting your HF transceiver on the air. The milliwatt output on the SWR analyzer is sufficient to find the dip, and also drive the built-in frequency counter.

The lower you mount your HF antenna on your vehicle, the worse your high frequency on-air performance. In recent tests, you lose about one S-unit of signal strength for every 2 feet you go down the side of your mobile unit. And yes, while you could get an HF transceiver with a built-in automatic antenna tuner to resonate an HF whip down low on the bumper, your ultimate communications capability will be dramatically undermined by a poor mobile



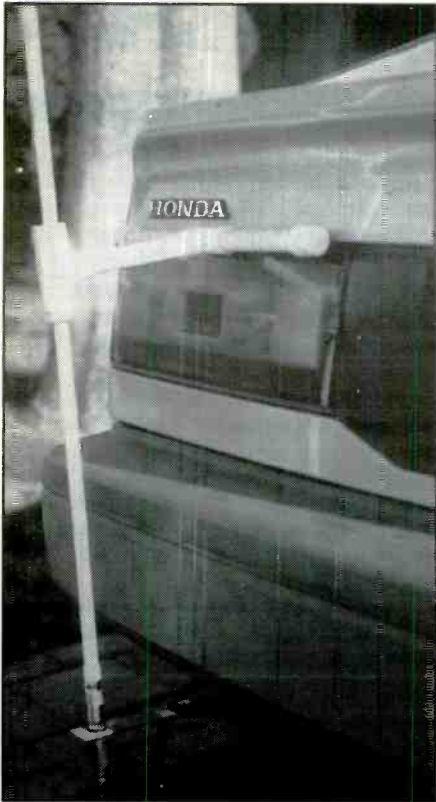

*This is NOT a good position for the base mount. The antenna is mounted too low.*

HF antenna installation. Sure, you'll probably get some signal out there on the airwaves, but nothing like the REAL signal from a top-mounted resonant whip or side-mounted automatic antenna tuner and non-resonant whip. Your choice.

Your local amateur radio dealer has all the necessary equipment and parts to out-





*Remote heads allow you to choose many locations for your high frequency radio system.*



fit your command post. Seek out a sales person at that dealership that expresses an interest in working closely with you on your emergency command center. Some of the antenna installations will be trial and error until you find the right combination that's going to work for your emergency personnel station. But keep this in mind—THERE IS NO ONE BEST ANTENNA OR EQUIPMENT THAT IS RIGHT FOR EVERYONE. Work closely with your ham radio or commercial radio dealer, and set up your SSB HF communications that will best suit your operating needs. ■

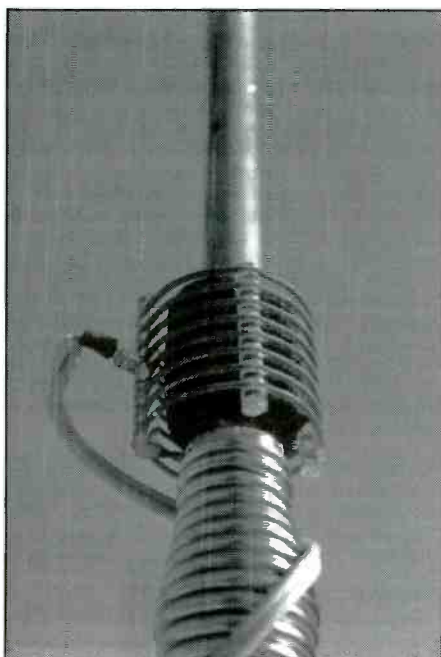

*Tune your whip at the base, not with a built-in tuner.*

***Is your cable company sucking you dry?***

We have the *Best* in

**CABLE CONVERTERS  
&  
DESCRAMBLERS!**

Everquest • Panasonic • Jerrold  
Zenith • Pioneer • Scientific Atlanta  
Oak • Eagle • Hamlin • Tocom

**Call For Your  
FREE Catalog Today!**

**1 800 624-1150**

And take a BITE out of high rental equipment fees.

**MD Electronics**

Dept. PC308 875 S. 72nd Street Omaha, NE 68114



CIRCLE 67 ON READER SERVICE CARD

**PICKS UP A WHISPER  
50 FEET AWAY!**



**NEW! High-power  
miniature transmitter  
on a single chip  
assembles in  
only 5 minutes!**

Simply attach the **VT-75** microtransmitter to any 3V to 12V battery and you can hear every sound in an entire house over 1 mile away! Super-sensitive circuit on a single chip even picks up footsteps from across a large room. Tunable from 80 to 130 MHz. Hear everything on any FM radio or wideband scanner tuned to the "secret" frequency you select. Unlimited uses for security, baby monitor, remote mic, etc. **Not a toy.** The **VT-75** meets many U.S. Gov't Military Specs and with **100mW RF output**, it is the smallest, most powerful miniature transmitter you can buy. Easily assembled even by a youngster in only 5 minutes and performs so well that it is the only miniature transmitter available **anywhere** that comes with a **full unconditional moneyback guarantee!** Dealers welcome. Law Enforcement inquiries invited. **VT-75** microtransmitter chip with miniature microphone, 9V battery connector and instructions - **\$49.98 + \$1.50 S&H** or save - buy 2 for \$45.00 each with free S&H! Call us toll free or send money order, Visa, or Mastercard for immediate shipping by U.S. Mail. COD's add \$4. Personal checks allow 21 days.

**DECO INDUSTRIES** • **BOX 607**  
**BEDFORD HILLS, NY 10507**  
**800-759-5553**

The leader in wireless design since 1976

CIRCLE 59 ON READER SERVICE CARD

**212-925-7000**

**SHORTWAVE RECEIVERS, HAM RADIOS, BOOKS  
ANTENNAS, SCANNERS, Business Radios.  
MOTOROLA, ICOM, YAESU, KENWOOD, SONY  
PANASONIC.**

... our 40th Year ... Worldwide shipping.  
Sales ... Service. Large Showroom. Open 7 days.

**Barry Electronics Corp.**  
WORLD WIDE AMATEUR RADIO SINCE 1950  
Your one source for all Radio Equipment!

Fax 212-925-7001  
512 Broadway, NYC, NY 10012

CIRCLE 3 ON READER SERVICE CARD

**AOR SCANNERS WITH CELLULAR**

Limited Supplies/Act Fast!

**CALL FOR GUARANTEED LOWEST  
PRICES ON AOR RADIOS**

We also sell a variety of CB's, Scanners,  
Shortwave Radios, Radar Detectors,  
Caller ID, and More.

For orders call: 1-800-TURBO

**TURBO ELECTRONICS**

366 N. Broadway, Suite 310  
Jericho, NY 11753  
Questions (516) 938-1946



**SURVEILLANCE  
& COUNTER SURVEILLANCE Electronic Devices**

Transmitter Kits... \$39.95 ppd., Voice Changers,  
Telephone Recording Systems, Vehicle Tracking,  
Bug & Phone Tap Detector & More!

**NEW! Telephone PRIVACY PLUS - defeats bugging devices  
and automatic tape recorders on your line. \$199.00**

FOR CATALOG SEND \$5.00 TO...  
**EDE P.O. Box 337, Buffalo, NY 14226 (716) 691-3476**

**MONITOR WITH THE PRO'S**

**- The World Scanner Report -**

published 10x/yr for casual hobbyists • follows the latest  
technology of scanning the radio frequency spectrum from  
DC-to-daylight • consumer & hobby electronics • do-it-  
yourself scanner/receiver projects. • SASE or 2 IRC for info, or  
US Funds: \$4/ea; \$25/yr; Canada\*15%; foreign\*25% surff50% air; MCVISA ok

**COMMtronics Engineering; PO Box 262478; San Diego, CA 92196**

CIRCLE 57 ON READER SERVICE CARD

# COMMUNICATIONS SHOP

**Advertising Rates:** POP'COMM subscribers are entitled to one FREE 30-word non-commercial classified ad per year. Enclose subscription name label with ad copy. For those people not in the previously mentioned group, non-commercial ads are 30 cents per word, including abbreviations and addresses; minimum charge \$6.00 per issue. Ads from firms offering commercial products or services are \$1.00 per word; minimum charge \$20.00 per issue. Boldface words are \$1.20 each (specify which words). Leading key words set in all caps at no additional charge. All ads must be prepaid in full at time of insertion; a 5% discount is offered for prepaid 6 time insertions. All ads must be typewritten double spaced.

**Approval:** All ad copy is subject to Publisher's approval and may be modified to eliminate references to equipment and practices which are either illegal or otherwise not within the spirit or coverage scope of the magazine.

**Closing Date:** The 10th day in the third month preceding date of publication. Because the advertisers and equipment contained in Communications Shop have not been investigated, the Publisher of Popular Communications cannot vouch for the merchandise listed therein. Direct all correspondence and ad copy to: PC Communications Shop, 76 N. Broadway, Hicksville, NY 11801.

**TOMCAT'S BIG CB HANDBOOK**, by Tom Kneitel. 221 large pages, fully illustrated. Complete guide to worldwide AM, SSB, Freeband. 27 MHz operations. Everything they never told you (legal & otherwise) from world's leading CB authority. Only \$13.95 plus \$4.00 postage (\$5.00 to Canada) from CRB Research Books, Inc., PO Box 56, Commack, NY 11725. (NYS residents add \$1.53 sales tax).

**TUNE In On Telephone Calls. Revised and Updated Edition!** Tom Kneitel's new 160-page book. Everything you need to know to effectively use a scanner and communications receiver to eavesdrop on private telephone calls from homes, offices, cars, ships, aircraft, trains. Explanatory text, photos, extensive listings section covers USA/Canada on HF, VHF, UHF, and above: thousands of locations, frequency assignments. Explains equipment, best techniques, laws regarding monitoring cellular, cordless, ship/shore, high seas, Air Force 1, airliners, 1-way paging, more. Only \$12.95 plus \$4.00 postage (\$5.00 to Canada) from CRB Research, PO Box 56, Commack, NY 11725. NY residents add \$1.44 sales tax. Dealer inquiries invited. Visa/MC OK. Tel: (516) 543-9169.

**WOW! UNDERSTANDING & REPAIRING CB RADIOS** by Lou Franklin. **Giant 380-page technical book picks up where THE "SCREWDRIVER EXPERTS" GUIDE leaves off. Includes circuit descriptions and troubleshooting guide for virtually all CB radios: 23 and 40-channel, crystal and PLL, solid-state and tube, AM, FM, SSB, CW, American, British and export models. Covers test equipment, transistor basics, synthesizers, receivers, transmitters, power supplies, T/R switching, antennas, interference, parts and accessory sources. Over 350 illustrations plus huge subject index. Moneyback Guarantee! Only \$29.95 plus \$3.50 U.S. & Canadian Air Mail, VISA/MC accepted. Free catalog of unique CB books, plans, and modification kits with order. Catalog only \$2. CBC INTERNATIONAL INC., BOX 31500PC, Phoenix, AZ 85046. Thousands of satisfied customers since 1976.**

**RADIO MONITORS NEWSLETTER OF MARYLAND FOR THE SERIOUS SHORTWAVE AND SCANNER LISTENERS.** PO BOX 394, Hampstead, MD 21704. For a one year subscription: **\$15.00. Sample copy: one dollar.**

**RADIO SHACK DEALER** - Lowest prices all Radio Shack equipment. PRO-2006 - only \$349; PRO-43 - only \$285; PRO-37 - only \$259; Sangean ATS803 - only \$169; SONY 2010 - only \$345. Order toll-free 1-800-848-3004. CoTronics, Inc., 2200 SE Federal Hwy., Stuart, FL 34994.

**SCANNER MODIFICATION HANDBOOK VOL. 1** by Bill Cheek ("Doctor Rigomortis"). The original 160-page book. Performance improvement modifications. Simple step-by-step instructions, many photos. Primarily PRO-2004 & PRO-2005, some for PRO-34, BC-200/205XLT, BC-705XLT. BC-705XLT. Restore blocked-out bands, speed up scanning rate, disable "beep," increase number of channels, improve squelch action, add an S-meter, interface with shortwave receivers, etc. Make the PRO-2004 & 2005 into a 6,400 channel scanner; put 3,200 channels into the PRO-34! Plus: cellular frequency charts, antenna info & mods, inside info on frequency management, operating hints, emergency power supplies, scanners & the law, lots more! Only \$17.95, plus \$4.00 shipping (\$5 to Canada). Residents of NY State add \$1.87 tax. **Big 220 page VOL. 2** with more mods for PRO-2004/5/6, PRO-34, PRO-2022, BC-760/950XL, BC200/205XL, now available. \$17.95 plus \$4.00 shipping (\$5.00 to Canada). NY State residents include \$1.87 tax. If both books are ordered at the same time, send only \$4.50 shipping. (\$5.50 to Canada). Order from CRB Research Books, Inc., PO Box 56, Commack, NY 11725. Visa/MC welcome. Tel: (516) 543-9169.

**CW? NO PROBLEM.** You can increase your speed, no matter how many times you've failed before. **Results guaranteed** when you follow the instructions. PASS Publishing's CW Mental-Block Buster program helps you **explode mental blocks** that hold you back. Based on 40 years of research, the **CW Mental-Block Buster** uses guided meditation, dynamic visualizations, and powerful affirmations to blast through mental blocks. **You can do code!** That means new bands, more contacts, more fun! (This is not a CW practice tape.) The **CW Mental-Block Buster** audio cassette and practice booklet are only \$29.95 ppd. in the US (NY residents add \$2.08 sales tax). (Quantity discounts available for classes.) PASS Publishing, PO Box 570, Stony Brook, NY 11790. VISA, MC, COD: 516-584-8164; FAX: 516-584-9409.

**MORSE CODE Got You Down?** Why let a mental block stand between you and upgrading? Use PASS Publishing's **CW Mental-Block Buster to blast through those barriers.** Just follow the instructions for 30 days - Results Guaranteed! Based on 40 years of research, the **CW Mental-Block Buster** uses guided meditation, dynamic visualizations, and powerful affirmations to blast through mental blocks. **You can do code!** That means new bands, more contacts, more fun! (This is not a CW practice tape.) The **CW Mental-Block Buster** audio cassette and practice booklet are only \$25.95 ppd. in the US (NY residents add \$2.08 sales tax). (Quantity discounts available for classes.) PASS Publishing, PO Box 570, Stony Brook, NY 11790. VISA, MC, COD: 516-584-8164; FAX: 516-584-9409.





**CQ's new videos  
bring the exciting world of  
amateur radio into your  
living room!**

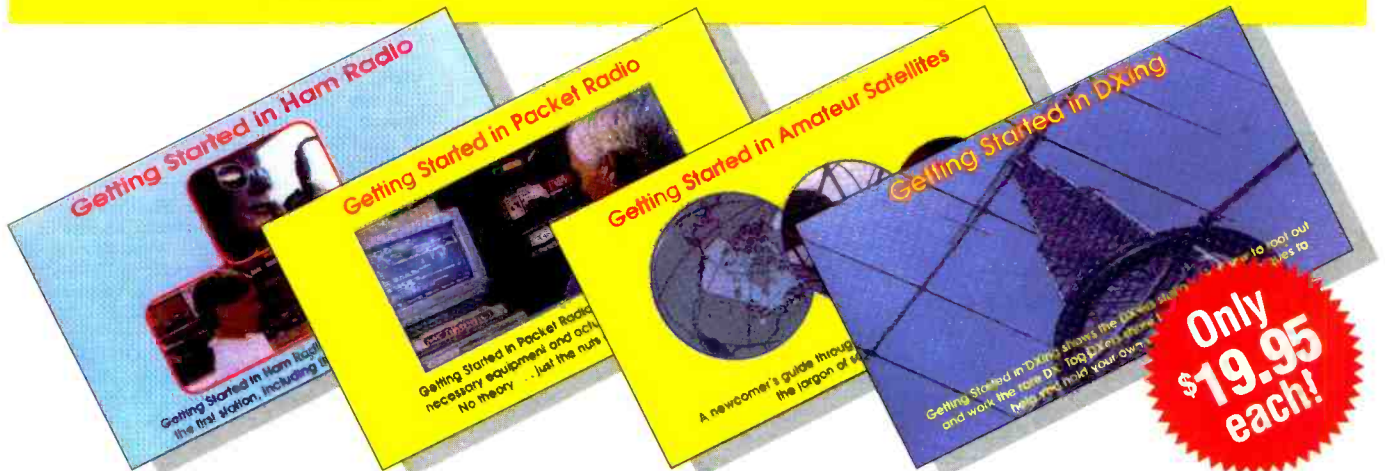

**Getting Started in Ham Radio.**

The authoritative fast paced video introduction to the fascinating world of ham radio. Shows how to select equipment and antennas. How to use repeater stations for improved VHF coverage. The importance of grounding and the basics of soldering. How to get the most out of your station, whether it's home-based, mobile or hand held!

**Getting Started in Packet Radio.**

This video will help de-mystify the exciting but sometimes confusing world of packet radio. Shows you how to get started in using your computer on the radio. Includes step-by-step instructions on making packet contacts and using packet bulletin boards, networks and satellites.

**Getting Started in Amateur Satellites.**

Shows you how veteran operators set up their satellite stations and how to find and track ham satellites with ease. How to access current satellites and contact far ranging countries around the world. This video is filled with easy to understand advice and tips that can't be found anywhere else.

**Getting Started in DXing.**

Top DXers share their experience on equipment, antennas, operating skills and QSL-ing. See hams work rare DX around the world. If you're new to DXing this video is for you. All the valuable information presented here may well give you the competitive edge you need to master the exciting world of DXing.

**The New CQ Video Library!**

Now, for the first time, CQ brings you all our experience in an exciting new format. Our videos will help you get started and improve your existing skills in amateur radio with our informative, helpful and easy-to-follow instructional videos.

Whether you're a new ham or just getting started in Packet, Satellite or DXing we've got your video. Each tape gives you first-hand tips from hams who are on the air. You'll get advice from some of our hobby's most experienced users. They take you under their wing and show you just what it takes to get on the air!

Filled with step-by-step tips in setting up your first station, operating satellites, using packet radio, maximizing your DXing potential, these videos

offer insights for beginners and experienced operators alike. You can order just the ones you want, or all four. It's up to you.

Send for your first video today and start growing now in the exciting and adventurous world of amateur radio!

**YES!** I want to receive all the information and tips included in the exciting video tapes indicated below. I'll send \$19.95 for each tape I order, plus \$3.50 shipping and handling per tape.

- Getting Started in Ham Radio
- Getting Started in Packet Radio
- Getting Started in Amateur Satellites
- Getting Started in DXing

Name \_\_\_\_\_

Address \_\_\_\_\_

City \_\_\_\_\_

State \_\_\_\_\_

Zip \_\_\_\_\_

Send \$19.95 each plus \$3.50 shipping and handling per tape (\$7.00 each for overseas shipment). All videos are available in VHS format only.

Payment:  Mastercard  Visa  American Express  Money Order  Check

Card # \_\_\_\_\_

Exp. Date \_\_\_\_\_

**Mail orders to: CQ Communications, Inc. 76 North Broadway, Hicksville, NY 11801**

**For Faster Service Call (516) 681-2922 or Fax (516) 681-2926. Dealer inquiries welcome.**

## SCANNER DIRECTORY

Keeps Vital Information Readily Available  
- Channel Number  
- Frequency  
- Service (Police, Fire etc)  
- Area (county, city etc)  
Small Slips into Bearcat 100 & 200 Case  
Entries for 200 channels, up to 20 Banks  
To Order, Send Check or M.O. for \$7.95 to  
C. Fisher, 3540A Miller Farms Lane,  
Duluth, GA 30136

CIRCLE 62 ON READER SERVICE CARD

## PAY TV AND SATELLITE DESCRAMBLING \*\*\*\*\*1993 EDITION\*\*\*\*\*

Includes programming cable box chips, hacking B-MAC, wireless cable (MMDS) descrambling, bullets, PLUS fixes and much more. ONLY \$18.95. Other PAY TV and SATELLITE DESCRAMBLING volumes, Volume 1 (BASICS), 1989, 1991, and 1992 \$15.95 each. Different turn-ons, bypasses, ECM's, schematics and counter ECM's in each. **THE COMPLETE WIZARD** Using the VCI data stream. \$15.95. Any 3/\$32.95 or 5/\$54.95. **SCRAMBLING NEWS** monthly. Keep up with the latest in satellite and cable descrambling. Everything that's new. \$32.95/yr. **OUR BEST DEAL** everything here, the video and much more for only \$129.95. New catalog \$1.

SCRAMBLING NEWS, 1552P HERTEL AVE., #123  
BUFFALO, NY 14216 Voice/FAX (716) 874-2088  
COD's are OK. ADD \$6

CIRCLE 74 ON READER SERVICE CARD

## SATELLITE T.V.

Factory Direct to Your Door  
Echostar • Startrak • Houston Tracker • Orbitron  
24 Hr. Pricing Hotline  
• Call for 1993 Huge Color Catalog  
• Domestic & International Systems  
• Huge Savings!  
Info & Orders  
516-763-6842 **ECHOTRAK** 305-344-6000  
4749 NW 98th Lane • Coral Springs, FL 33076

CIRCLE 61 ON READER SERVICE CARD

## SATELLITE TV

SATELLITE  
TV  
BUYING  
GUIDE

**NAME BRANDS AT 50% DISCOUNT**  
This FREE 24 page Consumer Buying  
Guide tells all about Satellite TV and  
lists guaranteed lowest prices.  
Salman, Inc.  
6310 N. University, No. 3798 • Peoria, IL 61612  
1-800-472-8626

CALL FOR

*Save Your Copies Of  
Popular  
Communications  
Order Your Binders  
Today! Call Jesse Jones  
Industries.*

*Now there's an easy way to organize  
and keep copies of your favorite  
magazine readily available for future  
reference. Constructed of heavy rein-  
forced board, covered with durable  
blue leather-like material. Title hot-  
stamped in gold.*

**Call Toll FREE  
7 days, 24 hours  
1-800-825-6690**

**CW Lite** is the **easiest** Morse Code training method in the world, bar none! And it is the **fastest**, too. Just closed your eyes and relax. This powerful **hypnosis cassette tape** does the rest. **Subliminals** speed you along! Only \$15.95 ppd in US (NY residents add \$1.28 tax). Order today! **PASS Publishing**, Box 570, Stony Brook, NY 11790. VISA, MC, COD: 516-584-8164; FAX: 516-584-9409.

**WORLD'S MOST UNUSUAL** Communications Books! A large selection of outstanding titles covering scanners, "confidential" frequency registries, bugging, wire tapping, electronic surveillance, covert communications, computers, espionage, monitoring, and more! New titles being added constantly! Ask for our big **FREE** catalog. CRB Research, BOX 56-PC, Commack, NY 11725.

**CB RADIO HACKER'S GUIDE!** Big 151 page book; pictorials, diagrams, text. Complete guide to peaking, tweaking, & modifying 200+ CB radios for enhanced performance & more features. Which screws to turn, which wires to cut, AM & SSB radios: Cobra, Courier, GE, Midland, Radio Shack Realistic, SBE, Sears, Uniden/President. Get the most from your CB radio & operations. Only \$18.95, plus \$4.00 shipping (\$5.00 to Canada). NY State residents add \$1.95 tax. Order from CRB Research Books, Inc., PO Box 56, Commack, NY 11725. Visa/MC OK. Tel: (516) 543-9169.

**PAN-COM INT'L CATALOG.** Over 350 Kits, Plans, Licensed/unlicensed. AM/FM broadcasting. Ham/CB/SW/DX. 1750M transmitters, Surveillance devices. Computers/Software, Science Projects, MORE! \$1 refundable. Box 130-P07, Paradise, CA 95967.

**COMMODORE 64 HAM PROGRAMS**—8 disk sides over 200 Ham programs—\$16.95. 29¢ stamp gets unusual software catalog of Utilities, Games, Adult and British Disks. Home-Spun Software, Box 1064-PC, Estero, FL 33928.

**SURVEILLANCE TRANSMITTER KITS** tune from 65 to 305 MHz. Main powered duplex, telephone, room, combination telephone/room. Catalog with **Popular Communications, Popular Electronics** and **Radio-Electronics** book reviews of "Electronic Eavesdropping Equipment Design," \$2.00. **SHEFFIELD ELECTRONICS**, PO Box 377785, Chicago, IL 60637-7785.

**NEW 1993 CB IMPORT/EXPORT RADIO CATALOG**—Hard to find CB Dealers, Equipment, Modification Kits and Plans—\$3.00. **LORD WYATT COMMUNICATIONS**, PO Box 030128PCJ, Brooklyn, NY 11203-0001.

**THE SCANNER HACKERS BIBLE**. 112 modifications. Includes: PRO-2004/5/6, Yaesu, Kenwood, Bearcat, Icom and others. Frequency fixes, modifications (scan rates, interfaces, programmable channels, improving operation, etc.), antenna plans, operation, laws, cellular telephone operation and frequencies, accessories, 10-codes and more. \$33.45. CODs: 1-602-782-2316, or fax 1-602-343-2141. **TELECODE**, Box 6426-CQ, Yuma, AZ 85366-6426.

**CANADIANS ONLY** Lowest prices. Bearcat-AOR, Uniden, Midland, Ranger, Galaxy, K40, Wilson, Antron, Valor, Sangean, MFJ, Diamond. Free Price List. Catalog \$2.00. Cellular Communications, 83 Galaxy Blvd., Unit #39, Rexdale, ONT., M9E 5X6. (416) 675-0029.

**"PERMANENT MAGNET MATERIALS SHORT COURSE."** Complete history, materials listing, glossary, specifications, applications, design criteria, sources. Details—\$2.50, order refundable. SJL Publishing, Dept. A004PC, Hanna, IN 46340-0152.

**FOR SALE:** Two Realistic CB walkie-talkies. model TRC-216. 40 ch., 5W. Uses Nicds or AAs. Includes carry case and wall charger, manual. Mint cond.—\$100 each. Realistic 40 ch. AM/SSB mobile CB. Mint cond with bracket, mic and manual \$135. Postal mo only! H. Ort, 270 Mechanic St., Red Bank, NJ 07701.

**SEXY? "The Real Spymart."** Home, office, cellular, defense, surveillance, nightvision, transmitters, more! Catalog—\$5.00. Operative Supply, PO Box 2343, Atlantic Beach, NC 28512.

**CELLULAR HACKERS BIBLE.** Theory—Hacks—Modifications—\$53.95. **TELECODE**, PO Box 6426-PC, Yuma, AZ 85366-6426.

**CABLE TEST CHIPS.** Scientific-Atlantic 8550-321, 8500-310, 311, 320, 321 (specify) - \$33.95. 8580-338—\$69.95, 8570/8590—\$79.95. ZENITH ZF-1—\$33.95. STARCOM6—\$33.95. STARCOM7—\$49.95. TOCOM 5503/07 VIP—\$33.95. **TELECODE**, PO Box 6426-PC, Yuma, AZ 85366-6426.

**KENWOOD & ICOM** Service Bulletins. 175+ pages covering all models—\$39.95. Catalog—\$3.00. CODs 602-782-2316/FAX 602-343-2141. **TELECODE**, Box 6426-PC, Yuma, AZ 85366-6426.

**VIDEOCIPHER** II /Satellite/Scanner/Cable/Amateur/Cellular/Repair Manuals. Modification Books & Software. Catalog—\$3.00. **TELECODE**, PO Box 6426-PC, Yuma, AZ 85366-6426.

**PRO-2004/5/6 OWNERS:** Search-and-Store finds unknown frequencies automatically. Internal no-holes installation - Keyboard control. Wired-tested-postpaid. Ten channel - \$24.95. Selectable to 255 channels - \$44.95. US checks or MO. SASE for information. Key Research, POB 846P, Cary, NC 27512-0846.

**CB, HAM, SWL DISCOUNT OUTLET.** Cobra, Uniden, Phillips, K40, A/S, Larsen, Firestick, Valor. Many hard to find items. Catalogs \$1.00. Mobile installations available at our retail store. Custom Auto Radio, Dept. P3, 660 Arsenal St., Watertown, MA 02173. Tel. 617-923-2122.

**MEN OF ACTION AND ADVENTURE** — Paladin Press has been described as "the most dangerous press in America." Millions of satisfied readers disagree. Outrageous and controversial books and videos on firearms, exotic weaponry, unconventional warfare, new identity, espionage and investigation, privacy, action careers and more! To order our 50-page catalog send \$1.00 to: Paladin Press, Box 1307-3BP, Boulder, CO 80306. (303) 443-7250.

**GRUNDIG** Satellite 500 shortwave radio. All accessories including VHS instruction tape. Hardly used, mint condition - \$250.00. Bob, 708-587-4647.

**VIDEO SYNC GENERATOR.** Restores Horizontal & Vertical sync lines from distorted analogue video formats. For information on completed units & pricing write: R.C. Distributing, Box 552, South Bend, IN 46624. Phone: (219) 236-5776.

**New 8th Edition, Kneitel's "Top Secret" Registry of U.S. Gov't. Radio Frequencies!** Giant 268 page book; largest amount of fed agency comms data ever published in 1 book. Includes worldwide American mil bases, FBI, DEA, Secret Service, Customs, ATF, Immigration, US Marshals, FCC, FAA, EPA, USCG, CIA, Border Patrol, IRS, State Dept, Dept. Agri., Nat'l. Parks, Postal Service, GSA, lots more, plus UHF aero. Also, Canadian listings, foreign gov't mil listings for Caribbean, Latin American, & Mideast hotspots. New key-freq. VHF/UHF index section. The ultimate insiders' scanner directory! Plenty of HF freq. info, too. Lots of new & updated data. All for \$21.95, plus \$4.00 shipping/handling (Canada \$5.00). Residents of NY State please add \$2.21 tax. From CRB Research Books, Inc., PO Box 56, Commack, NY 11725. VISA/MC accepted. Tel: 1-(516) 543-9169.

**WANTED:** Regency TS-2 (Turbo Scan 800) scanner. Any condition—working or not. Please leave message on machine. Dave (708) 358-2249.

**Texas Radio Directory** by David Stall, N5MKK. Best scanner guide available for Texas. \$16.00 ppd. Luna Lumen, Box 58023, Houston, TX 77258.



**CALLING ALL AUTHORS!** Communications book publisher considering new projects: Scanners, Communications, SWL, CB, Freq. Directories, & related. Mail us your proposed book outline. Don't send manuscripts. All ideas considered. Editorial Dept., CRB Research Books, PO Box 56, Commack, NY 11725.

**METAL DETECTORS** - If you like scanning or SWLing, you will really "DIG" metal detecting. Special White's Eagle II-SL reg. \$895, only \$599. Call 1-800-848-3004. CoTronics, Inc., 2200 SE Federal Hwy., Stuart, FL 34994.

**CELLULAR, 2-WAY, CB, SCANNER ANTENNAS** for base, portable, mobile. High quality at discount prices. Price list \$1 (refundable) **Radio Communications Services**, 1007 Eastfield, Lansing, MI 48917.

**GUIDE TO THE AR1000.** We publish a complete, 90-page guide for the operation and use of all AOR-AR1000 and Fairmate HP-100/200 scanners. Comes with 10 scan bank templates and a handy, 6-panel, folded Quick Reference Card. \$18.45, including S&H in the U.S. Design EQ, PO Box 1245-PC, Menlo Park, CA 94025. 415-328-9181.

**FIND OUT WHY** Scanner Enthusiasts choose **DataFile Software** for their scanner enhancements. Unique, powerful, affordable! DOS based. S.A.S.E. details. **DataFile, Box 20111 PC, St. Louis, MO 63123.**

**UNIDEN MODIFICATION INSTRUCTION MANUAL and EAVESDROPPING FOR FUN AND PROFIT** combined. A complete collection of modifications for the BC100XLT, BC200/205XLT, BC855XLT, BC580/600XLT, BC760/950XLT, Regency 4020, 4030, TS-1, TS-2. Includes cellular mods, adding 50 to 200 channels, increase scan speed to 250 percent, more battery time, remote control, transportable power, frequency charts, pictures and more. **ONLY \$14 to: STARLITE MFG. INC., 4424 Clemice Ln., Montgomery, Alabama 36106.**

**REALISTIC MODIFICATION INSTRUCTION MANUAL and EAVESDROPPING FOR FUN AND PROFIT** combined. A complete collection of modifications for the PRO-43, PRO-39, PRO-37, PRO-35, PRO-34, PRO-2026, PRO-2022, PRO-2006, PRO-2005. Includes cellular mods, adding channels, increase scan speed to 100 percent, more battery time, remote control, transportable power, frequency charts, pictures and more. **ONLY \$14 to: STARLITE MFG. INC., 4424 Clemice Ln., Montgomery, Alabama 36106.**

**ATTENTION! WIRED REMOTE CONTROL FOR PRO-2006.** Easy installation. Controls scan, manual, search up/down, and all numbers. Don't reach for those buttons anymore; have complete control in the palm of your hands. Plans-\$10.00. M.O. preferred, checks acceptable. Parts assembled/unassembled available. SASE for more information. Boedecker Electronics, 1653 Parkside, Lewisville, TX 75067.

**NATIONAL SCANNING REPORT**, America's #1 all-scanning magazine. Articles, frequencies, new products, more. One year subscription (\$17.50) includes custom frequency print-out for your country. Order toll-free 1-800-423-1331. Sample copies \$3.00 cash from Box 360, Wagontown, PA 19376.

**Enhance your SSB CB radio.** Kits and plans for improvements. Send \$3 for Catalog, Large SASE for flier. Blyleven Electronic Systems, 91 Lois St., Unit #5, Kitchener, Ontario, Canada N2B 2A2.

**TECHNICAL HELP WANTED:** Experienced 2-Way Radio Repair Technician. Amateur Radio Equipment Repair Experience Beneficial. Send Resumes To: 829 Lynnhaven Pkwy., Suite 130, VA Beach, VA 23452.

**RCI-2950 Modification Manual.** Including power and modulation increase. Clarifier, receiver modifications. Operating hints and more. Parts included. \$20.00 ppd U.S. Money Order. \$25.50 COD (MO residents add \$1.15 tax). Scott, PO Box 510408, St. Louis, MO 63151-0408. (314) 846-0252.

**THE QUANTUM LOOP**—A compact, high gain ferrite rod antenna for serious BCB DX'ers. Details—SASE. Radio Plus+ Electronics, 3635 Chastain Way, Pensacola, FL 32504.

**R-390-A SERVICE.** Module repair and alignment to complete remanufacture, new front panels, knob sets, VFO calibration, new filter capacitors, tubes, squelch modification, 20 years expert service, 2-week turnaround, very reasonable, any condition accepted. (419) 726-2249.

**SPECTRUM DISPLAYS:** Defense electronics SD-102, dual channel 10.7 input, solid state, 5 CRT, see 10 MC spectrum, use with any (2) scanners, like new. (419) 726-2249.

**SCANNER FREQUENCY SEARCH SERVICE.** Hear all there is to hear! SAE to: Heald, 6886P, Jefferson, North Branch, MI 48461.

**TIPS** for getting the most from your scanner. Includes over 1300 frequencies. \$3.00. John Bailey, 55 N. 1100 W., Vernal, UT 84078.

**THE CipherAce Series, Books, MS-DOS Software, Hardware.** SASE or call (407) 855-6148. Charles Stewart, 1197F, Pickrel Cir, Orlando, FL 32839.

**ANTIQUÉ RADIO ENTHUSIASTS!** "Wireless Trader"... your bi-weekly hotline to deals! 24 issues \$19.95. Sample \$2.00. Trader Publications, 4290 Bells Ferry Road, Suite 106-36PC, Kennesaw, GA 30144.

**NEW BC-2500XLT call!! New BC-8500XLT call!!** AR-1500 with SSB - \$469, AR-2800 - \$439, AR-3000A - \$989, BC-200XLT - \$245, BC-760XLT - \$275, BC-855XLT with 100 memories - \$225. CBs, shortwaves, books, antennas. If you don't see it call for price quote! Free UPS shipping and insurance to 48 states! We ship COD daily and we take trades! Price sheets \$1.00. GALAXY, Box 1202, Akron, OH 44309. (216) 376-2402. 9-4:30PM. Our 10th year!

**FOR SALE:** ICR1 New \$385.00; AEA CP1 Computer Interface w/Commodore 64 Software (New) \$150.00; McKay Dymek DA100 Active Antenna \$75.00; SBE Opti-Scan w/Instruction Book and Cards \$100.00; Kenwood SP100 Speaker (new) \$50.00; Handic 6 Channel W/T \$35.00; Antenna Specialist VHF/UHF Pre-Amp \$35.00; Gladding Islander AM/FM/MB/LW/VHF with RDF \$35.00; Regency 8 Channel Crystal Scanner \$25.00; Grove Spectrum Probe \$25.00. John Lewitsky, 615 Main Street, Stroudsburg, PA 18360. (717) 629-3403.

**WANTED:** R-390 receiver, especially model in use by Air Force in early '70's. Any condition. Stan Sullivan, PO Box 270, Montevallo, AL 35115. (205) 665-2065.

**AR1000XC.** Excellent condition. All accessories and original box. \$350 or best. (313) 545-0013. Includes FREE 90 page guide purchased separately.

**WANTED:** ARC-5 receivers, prefer unaltered sets, other ARC-5 stuff. J. Broussard, 312 Guilbeau, Breaux Bridge, LA 70517.

**COMMODORE C-64 Users.** Let's unite and trade knowledge and programs. Wanting Printer, accessories. Robert Perez, 7161 Southwest Fifth Street, Miami, FL 33144. Call: (305) 460-3374.

**W2ZZJ**, the Fulton County Historical Society will operate W2ZZJ on July 17 and 18, 1400-2000Z, on the General class phone portion of 40, 20 and 15 meters, and, on the Novice 10 meter phone band, to celebrate the 167th anniversary of the birth of Dr. Mahlon Loomis, the American wireless telegraphy pioneer, who was born at nearby Oppenheim. For certificate send QSL, contact #, and a #10 SASE ONLY to W2ZZJ, HC Box 80, Stratford, New York 13470.

**FOR Sale:** Sony ICF 2010. One and a half years old, excellent condition, manual box and accessories. Non-smoker, \$269. Call Bob at (210) 614-3920.

## Advertisers' Index

AMC Sales, Inc. ....	53
A.R.R.L. ....	13
Ace Communications. ...	21,80, Cov III
Advanced Electronic Applications. ...	15
Antenna Specialists.....	6
Antenna Supermarket.....	19
Antique Radio Classified.....	57
Barry Electronics Corporation.....	76
Boedecker Electronics.....	38
CB City International, Inc.....	38
CRB Research.....	54,72
Cellular Security Group.....	73
Clear Channel.....	28
COMMtronics Engineering.....	53,76
Communications Electronics.....	17
Consumertronics.....	57
Counter Intelligence Applications.....	23
DECO.....	76
Delta Research.....	73
Drake, R.L. Company.....	5
EDE.....	76
ECHOTRAK.....	78
Electronic Equipment Bank.....	1
Fisher, Carey.....	78
Fort Worth Computers.....	20
G & G Electronics.....	72
Gilfer Shortwave.....	4
HR Bookstore.....	67
ICOM America.....	42, Cov IV
J & J Enterprises.....	20
JPS Communications, Inc.....	37
Japan Radio Company, Ltd.....	Cov II
Jesse Jones Industries.....	78
Jo Gunn Enterprises.....	45
L & L Electronics.....	23
Lentini Communications, Inc.....	38
M.D. Electronics.....	75
MFJ Enterprises, Inc.....	14
MARYMAC Industries, Inc.....	34
MoTron Electronics.....	54
National Amateur Radio Assoc.....	4
OPTOelectronics.....	11
R.C. Distributing.....	57
REACT International.....	34
Radioware Corporation.....	51
Satman, Inc.....	78
Scanner World USA.....	8
Scrambling News.....	78
Signal Engineering.....	38
Software Systems Consulting.....	28,72
Somerset Electronics, Inc.....	32
Standard Amateur Radio Products.....	33
Turbo Electronics.....	76
Universal Electronics, Inc.....	61
Universal Radio, Inc.....	3
Vanguard Labs.....	34
Viking International.....	10
Wilson Antenna, Inc.....	23
Xandi Electronics.....	57
Yaesu U.S.A.....	7

**Reach this dynamic audience with your advertising message, contact Don Allen, N9ALK at 217-344-8653, FAX 217-344-8656**

## Total Coverage Radios

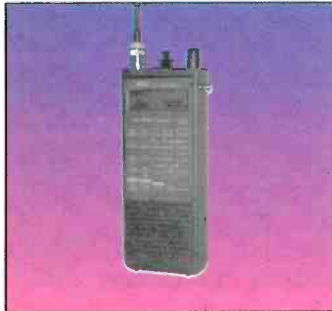

### AOR AR1000XLT

AM Broadcast to Microwave  
1000 Channels  
500KHz to 1300MHz coverage in a programmable hand held. Ten scan banks, ten search banks. Lockout on search and scan. AM plus narrow and broadcast FM. Priority, hold, delay and selectable search increment of 5 to 995 KHz. Permanent memory. 4 AA ni-cads and wall plus cig charger included along with belt clip, case, ant. & earphone.

Size: 6 7/8 x 1 3/4 x 2 1/2. Wt 12 oz.

Fax fact document # 205

**\$449.<sup>00</sup>**

### AR2500

2016 Channels

1 to 1300MHz

Patented Computer Control

62 Scan Banks, 16 Search Banks, 35 Channels per second. Patented Computer control for logging and spectrum display. AM, NFM, WFM, & BFO for CW/SSB. Priority bank, delay/hold and selectable search increments. Permanent memory. DC or AC with adapters. Mtng Brkt & Antenna included.

Size: 2 1/4H x 5 5/8W x 6 1/2D. Wt. 1lb.

Fax fact #305

**\$499.<sup>00</sup>**



### AR3000

400 Channels

100KHz to 2036MHz Patented computer control. Top rated receiver in its class, offers AM, NFM Wide FM, LSB, USB, CW modes. 400 scan memories. 4 priority channels. Delay & hold & Freescan. AC/DC pwr cord and whip ant.

Size: 3 1/7H x 5 2/5W x 7 7/8D. Wt 2lbs., 10oz.

Fax fact document #105

**\$1195.<sup>00</sup>**

### AR2800

1000 Channels

.5 to 1300MHz

AM Broadcast to Microwave 1000 Channels 500KHz to 1300MHz coverage in a programmable mobile. Ten scan banks, ten search banks. Lockout on search and scan. AM plus narrow and broadcast FM. Priority, hold, delay and selectable search increment of 5 to 995 KHz. Permanent memory. DC or AC with adapters. Mtng Brkt & Antenna included.

Size: 2 1/4H x 5 5/8W x 6 1/2D. Wt. 1lb.

Fax fact #350

**\$449.<sup>00</sup>**



### AOR AR1500

Full Coverage with SSB and 1000 Channels.

500KHz to 1300MHz. Ten scan banks, ten search banks. Search lock and store. BFO. 2 Antennas. AM/NFM/WFM. Selectable increments. Tons of features,

small size:  
5 7/8 x 1 1/2 x 2.  
Wt 14 oz.

Fax fact document # 250

**\$499.<sup>00</sup>**

## Scanners with Shortwave



Yupiteru 8-1300MHz Mobile or Hand Held Units.

**\$399.<sup>00</sup>** each.



Top rated receivers from Japan now available in the USA. Tune down to 100KHz. Sensitivity guaranteed from 8MHz up. 200 scan channels. AM/NFM/WFM. No gaps, no cut-outs. Mobile is super slim line. AC/DC. Order MVT8000, includes antenna, mbl mnt. Order MVT7000 for the hand held. Complete with Ni-Cads, Charger, antenna & earphone.

Fax fact document #275



New Bearcat units cover 29-1300MHz on those frequencies allocated for NFM or AM. Model 8500 mobile offers 500 channels. Four hundred channels in 2500 model and 890 model offers 200 channels with coverage from 29 to 956MHz. Lots of nifty features and plenty of memory, but delivery not until late Spring or Summer of 1993.

Fax fact document #420

**Bearcat 2500XLTA .....\$369.00**

**Bearcat 8500XLTC .....\$389.00**

**Bearcat 890XLTB .....\$279.00**

Mobile Scanners

**\$249.<sup>95</sup>**

Bearcat 760XLTM



100 Channel 800 MHz

Five banks of 20 channels each. Covers 29-54, 118-174, 406-512 and 806-954MHz (with cell lock). Features scan, search, delay, priority, CTCSS option, lockout, service search, & keylock. Includes AC/DC cords, mounting bracket, BNC antenna. Size: 4 3/8 x 6 15/16 x 1 5/8. Weight: 4.5lbs.

Fax fact document #550

Other Mobile Scanners

**BC590 .....\$199.95**

**BC560XLTZ .....\$99.95**

Fax fact on above: #560

Scan/CB/Highway Patrol/WX. X,K,Ka,Wide & Laser

**\$399.<sup>00</sup>**

Scans police pre-programmed by state channel plus full radar and laser alerts in one small unit. Weather, CB receive & mobile relay.

Size: 5 5/8 x 4 7/8 x 1 3/4. Wt: 1.5lbs.

Fax fact #580



Trident TR-33WL

Other Pre-Programmed Scanning Receivers

**BC350AS .....\$129.00**

**BCT2 .....\$149.00**

**BC700AS .....\$169.00**

Fax fact on all above: #580



## Hand Held Scanners



### AOR 900

**\$249.95**

100 Channel 800 MHz

Five scan banks 5 search banks. Covers 27-54, 108-174, 406-512 and 830-950 MHz (no cell lock). Features scan, search, delay, priority, permanent memory, lockout, backlight, & keylock. Includes AC/DC adapter, belt clip, antennas, & NiCad.

Size: 5 3/4H x 2W x 1 1/2D. Wt: 12oz..

Fax fact document #650

### Bearcat 200XLTN

**\$229.95**

200 Channels 800 MHz

Ten scan banks plus search. Covers 29-54, 118-174, 406-512 and 806 956MHz (with cell lock). Features scan, search, delay, 10 priorities, mem backup, lockout, WX search, & keylock. Includes NiCad & Chgr.

Size: 1 3/8 x 2 11/16 x 7 1/2. Wt. 32 oz.

Fax Facts # 450



### Other hand held scanners

**Bearcat 100XLTN 100Ch H/L/U .....\$159.95**

**Bearcat 70XLTP 20Ch H/L/U .....\$139.95**

**Bearcat 55XLTR 10 Ch H/L/U .....\$99.95**

Fax facts on all above: #475

## Table Top Scanners



### Bearcat 800XLX

12 bands and 40 channels with 800MHz and nothing cut out. AC or DC.

Fax facts #690

**\$219.<sup>95</sup>**

### Other Table Top Scanners

**Bearcat 855XLTE 50Ch w/800 .....\$159.95**

**Bearcat 142XLM 10Ch H/L/U .....\$84.95**

**Bearcat 147XLJ 16 Ch H/L/U .....\$89.95**

**Bearcat 172XM 20Ch H/L/U/Air.....\$99.95**

**Bearcat 210 16Ch H/L/U/Air .....\$129.95**

Fax facts on all above: #675

### ★ Here's the fine print you've been looking for:

\$8.95 air freight is available for packages weighing 8 pounds or less sent to destinations within the Continental U.S. Overnight service is available to most urban areas at little or no surcharge. Outlying areas may require two days or more for delivery. Please call toll free if you have questions regarding ACE Communications radio receivers are manufactured under and/or licensed under one or more of the following United States patents. 3,961,261 3,962,644 4,000,468 4,027,251 4,092,594 4,270,217 4,455,679 4,461,036 4,627,100 4,932,074 5,163,161. AOR, ACE Communications and Yupiteru are trademarks of C.D. Corporation, an Indiana corporation. All other trademarks remain the property of their respective companies. We make no claims of ownership or interest to any trademarks other than those listed above. We make every effort to insure the accuracy of these contents, but disclaim responsibility for typographical errors. We make every effort to stay current, but prices & specs are subject to change without notice. Please call toll free to confirm prices, delivery and specs before you order.

# 800-445-7717 Fax Facts 317-849-8683

Fax Orders 800-448-1084

Computer BBS Modem & Fax/Modem, 317-579-2045.

Toll Free Tech Support, 800-874-3468

International Fax: en Espanol, en Francais, und auf Deutsch,  
or just fax in plain English to: 317-849-8794



**ACE**  
COMMUNICATIONS

10707 East 106th Street, Fishers, IN 46038



**Call Toll Free,  
24 Hours A Day!**



### Service & Support hours:

Mon.-Fri. 9AM to 6PM, Sat. 10-4 EST.  
Mastercard, Visa, Checks, Approved P.O.'s & COD (add \$5.50) & AMEX. Prices, specifications and availability subject to change. Flat rate ground shipping and handling charge only \$5.95 per unit. Express Air only \$8.95, for most units, to most locations. One week trial, no returns accepted two weeks after original receipt without substantial restocking charge. All units carry full factory warranty. Indiana residents add 5 per cent sales tax.

### Fax Facts Service

Get instant tech information FREE from your Fax or Computer!  
You can obtain specs, freq. info, software and more from our automated services. For fax facts, call from your stand alone fax machine and follow the voice prompts. Use the BBS from your modem or fax/modem equipped computer. Dial 317-849-8683 for fax back service, or dial 317-579-2045 for our computer bulletin board service.

### No fax, no computer?

Call our Tech Talker from your touch tone phone and hear automated messages giving you complete spoken detail on all of these products and more! Key in the fax fact number, or follow the prompts. Try it today! Dial 317 579-2047

**Fly It!**  
**\$8.95**





# Wide Band Receivers...



ICOM has broken the barriers with its new line of wideband receivers built to go the distance. Introducing the IC-R1 handheld receiver, the IC-R72 HF receiver and the IC-R100 multi-purpose receiver.

**IC-R1.** The smallest wideband handheld available today, the IC-R1 continuously covers 100kHz-1300MHz with AM, FM and Wide-FM modes. This tiny receiver measures just 1.9"W x 4.0"H x 1.4"D.

Easy operation is a snap with the IC-R1's Dual Frequency Selection (direct keyboard and rotary tuning), 100 memories and a 24-hour clock completes the world's smallest full-featured handheld receiver.

**IC-R100.** Install the IC-R100 at home or in your car. Listening pleasure is guaranteed

with continuous coverage from 100kHz-1856MHz in AM, FM and wide FM modes. Monitor VHF air and marine bands, emergency services, government as well as amateur stations. 121 fully programmable memory channels, multiple scanning system, an automatic noise limiter, built-in preamplifier and attenuator, clock with timer and built-in backup lithium battery make the IC-R100 the perfect package for mobile or base operation.

**IC-R72.** The IC-R72 continuously receives 100kHz-30MHz in SSB, AM and CW modes with very high sensitivity. An optional UI-8 provides FM reception. Additional features include: Noise blanker, five scanning systems, AC/DC operation, internal backup battery, built-in clock and ICOM's DDS System. The IC-R72 boasts a 100dB wide dynamic range while

an easy-to-access keyboard provides convenient programming versatility. The easy to operate IC-R72 is superb for short wave listeners.

The IC-R1, IC-R72 and IC-R100 join ICOM's current line of professional quality receivers... the IC-F71A, IC-R7000 and IC-R9000. ICOM... expanding the horizons to bring you better technology, today. See the complete line of quality ICOM receivers at your local authorized ICOM dealer today.

For a brochure on this or any other ICOM product, call our Literature Request Hotline 1-206-450-6088.

**ICOM**  
First in Communications

# ...That Go The Distance.

ICOM America, Inc., 2380-116th Ave. N.E., Bellevue, WA 98004 / Customer Service Hotline (206) 454-7679  
18102 Skyway South, Ste. 52-B, Irvine, CA 92714 ICOM Canada, A Division of ICOM America, Inc., 3071-#5 Road, Unit 3, Richmond, B.C. V6X 2T4 Canada  
For inquiries in UK contact: ICOM (UK) Ltd Unit 9, Sea Side, Herne Bay, Kent CT6 8LD, UK Phone 0227 741741 Fax 0227 741742  
All stated specifications are subject to change without notice or obligation. All ICOM radios significantly exceed FCC regulations limiting spurious emissions. R1593

CIRCLE 91 ON READER SERVICE CARD